

Airworthiness Directive: #112

Date: July 31, 1996

Subject: Taildragger Cages

Compliance: Mandatory

Models Effected: All S-6 Taildraggers

Stress cracking was reported on one S-6 taildragger cage in the area shown below. All S-6ES, S-6S and S-6XL taildragger models must be inspected to determine if this problem exists.

If no cracks are found, than a periodic inspection every 250 hours must be performed. If inspection reveals cracks, repair as shown below.

Note: Please notify RANS, Inc. if you find cracks on your S-6.

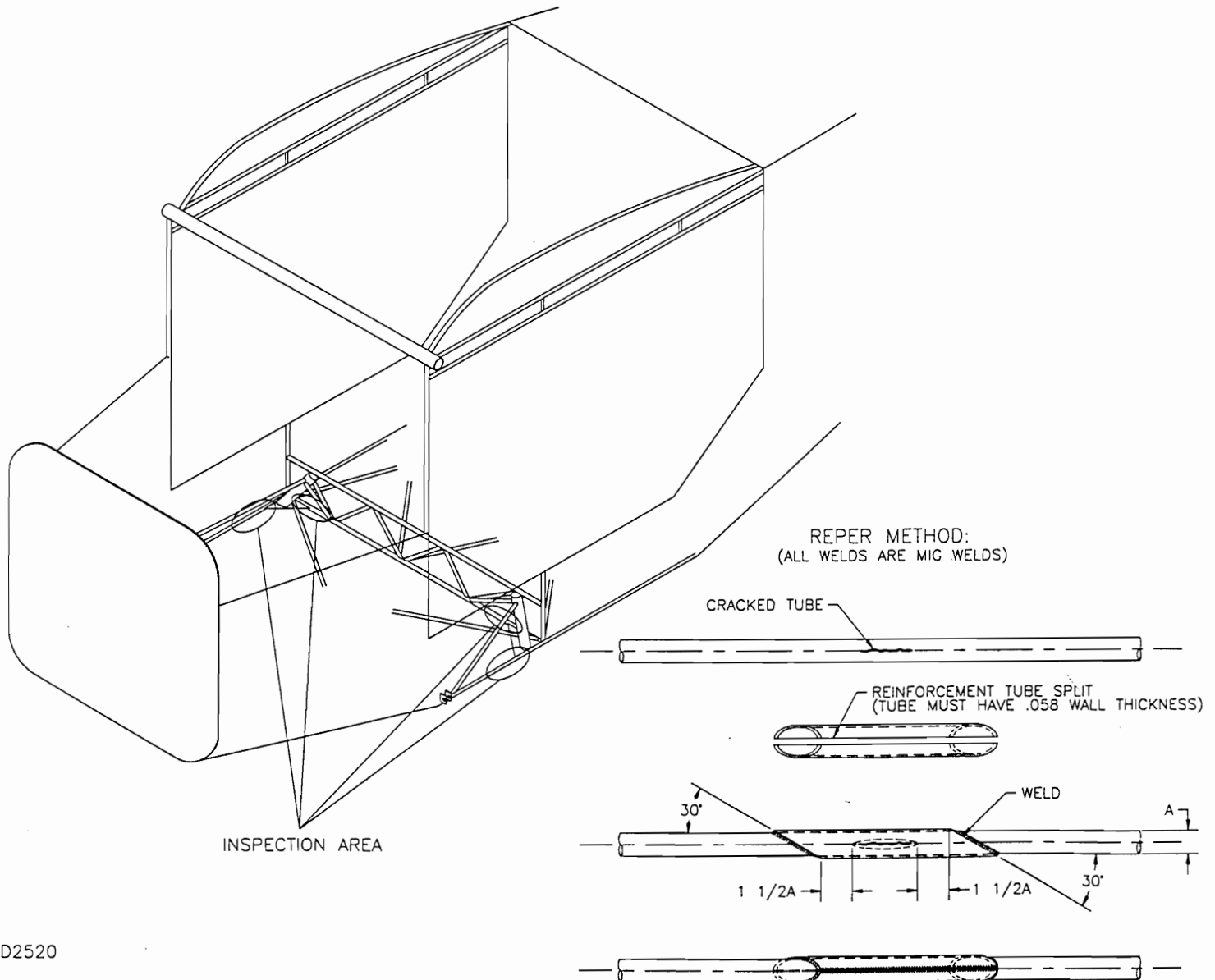

MD2520