

13 – ROTAX 912ULS ENGINE INSTALLATION

ROTAX 912ULS ENGINE THRUST OFFSET	13A-03
HOUR METER RELAY	13G-03
REMOTE BATTERY POST INSTALL.....	13J-03

MEASURE FROM FIREWALL
AT TOP ENGINE ATTACH MNT.

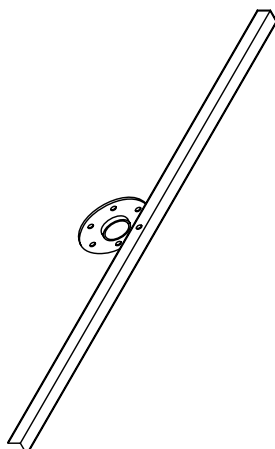
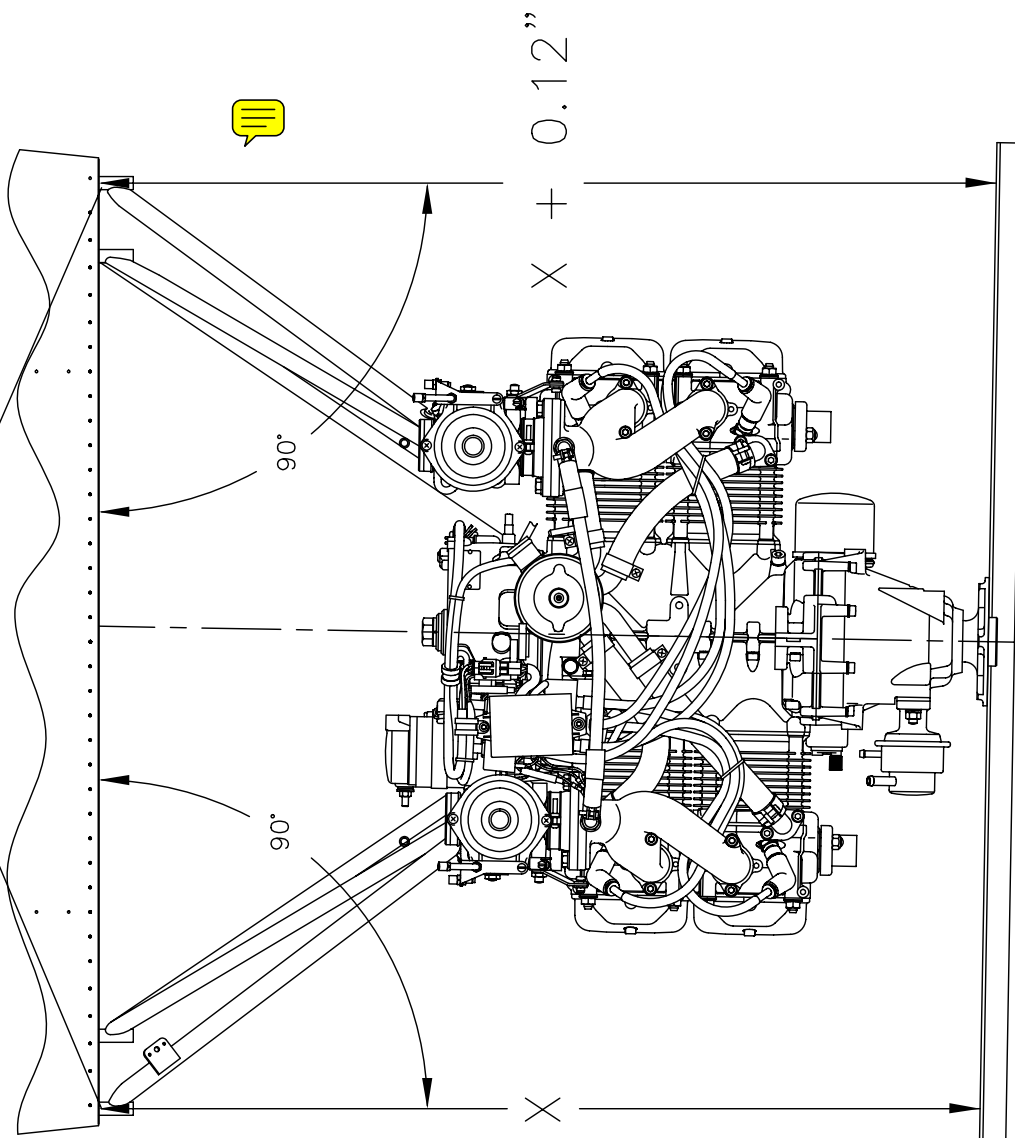

MD5459

RAMS S-19 VENTERRA
ROTAX 912ULS ENGINE THRUST OFFSET
FIGURE 13A-03

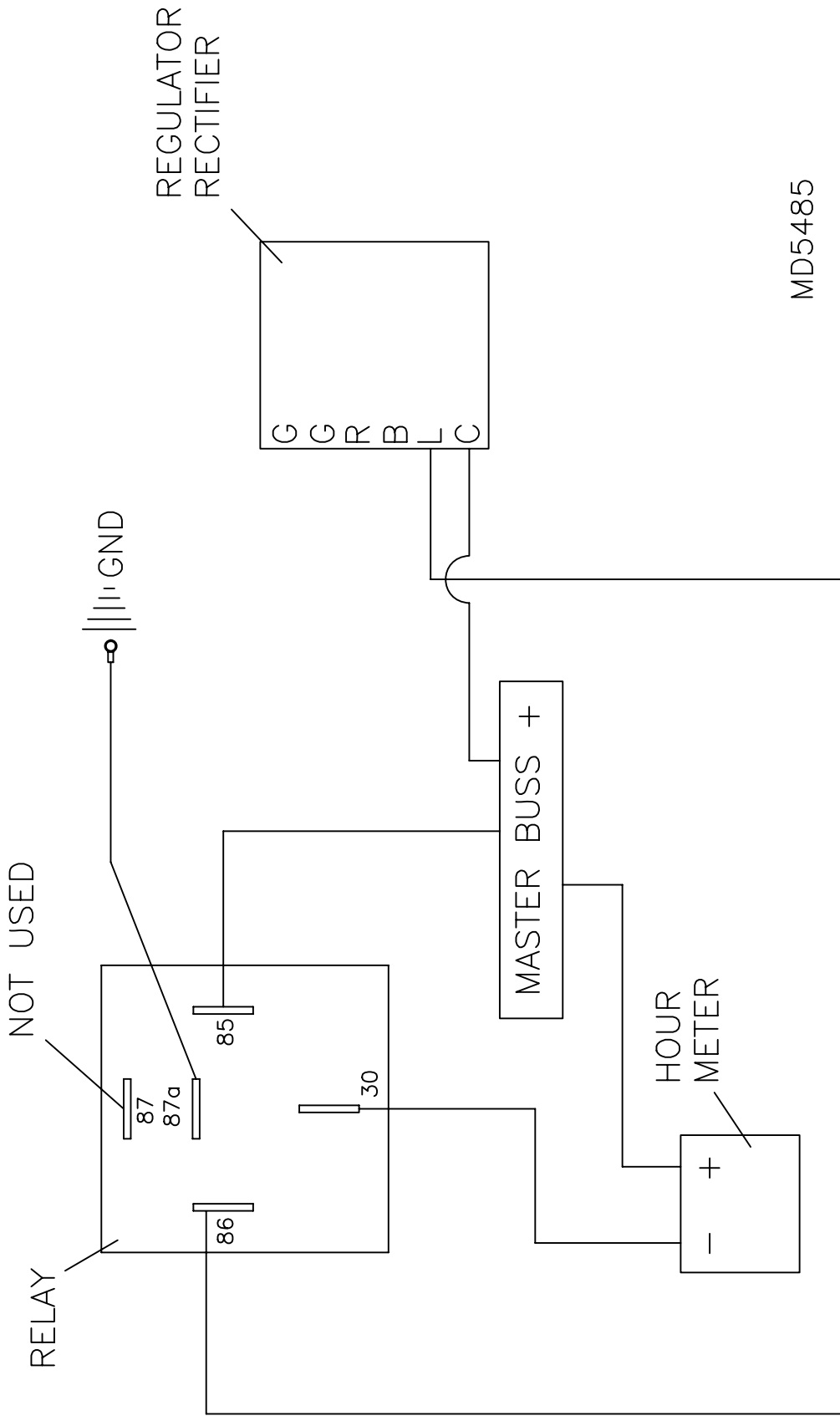

MD5485

RAMCO S-19 VENTERRA
HOUR METER RELAY
FIGURE 13G-03

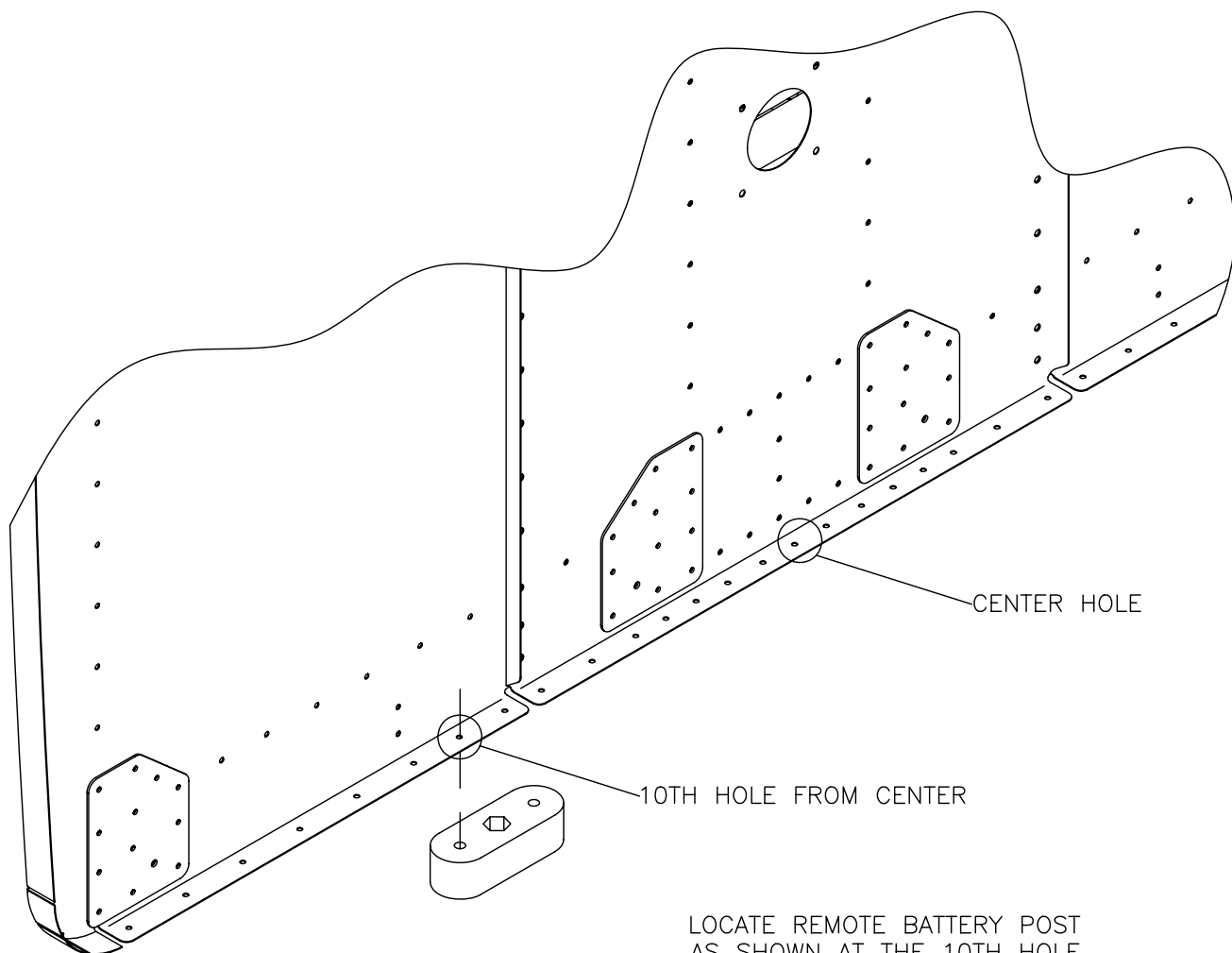

LOCATE REMOTE BATTERY POST
AS SHOWN AT THE 10TH HOLE
(INCLUDING THE CENTER HOLE)
FROM THE CENTER OF THE
FIREWALL AND TRANSFER DRILL
ACCORDINGLY

MD5515

RANS S-19 VENTERRA
REMOTE BATTERY POST INSTALL
FIGURE 13J-03

04/01/2011

14 – SPINNER & COWLING INSTALLATION

SENENICH GROUND ADJUSTABLE PROP – 12” SPINNER TEMPLATE.....	14-04
3-BLADE WARP DRIVE PROP – 12” SPINNER TEMPLATE	14-04A
SPINNER DRILLING.....	14-07
SPINNER ALIGNMENT MARKS	14-10
SPINNER NUT PLATE INSTALLATION.....	14-11
1/4 TURN FASTENER INSTALLATION	14-22
COWLING TO SPINNER SPACING.....	14A-02
COWLING FASTENER SPACING.....	14A-09
OIL CHECK DOOR TEMPLATE	14A-17

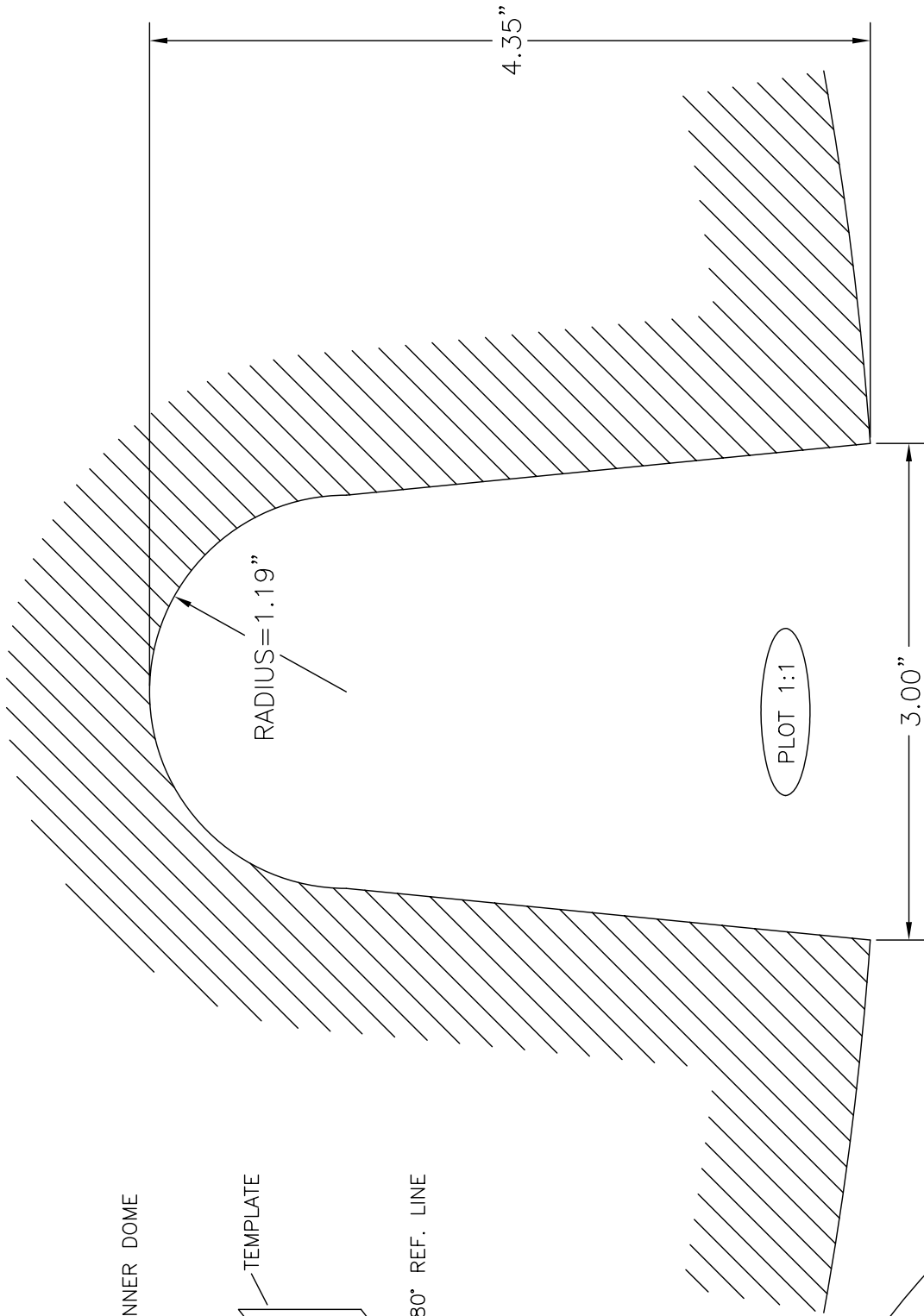

MD5228

RRANDS S-19 VENTERRA
SENENICH GROUND ADJUSTABLE PROP
ROTAX 912ULS - 12" SPINNER TEMPLATE

FIGURE 14-04

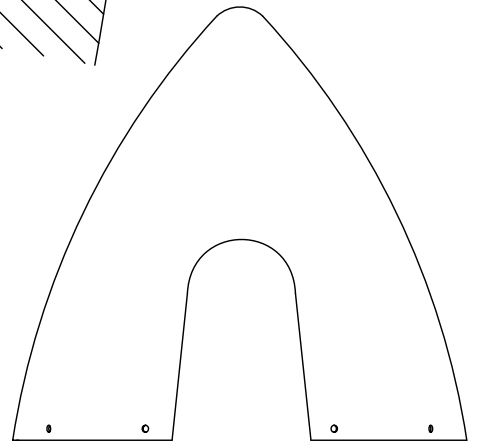
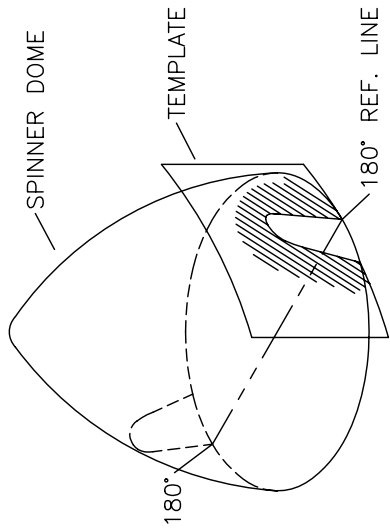

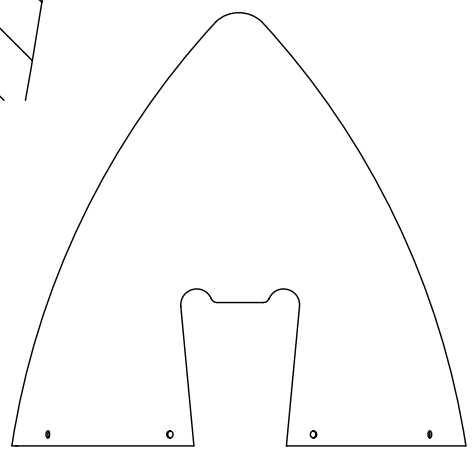
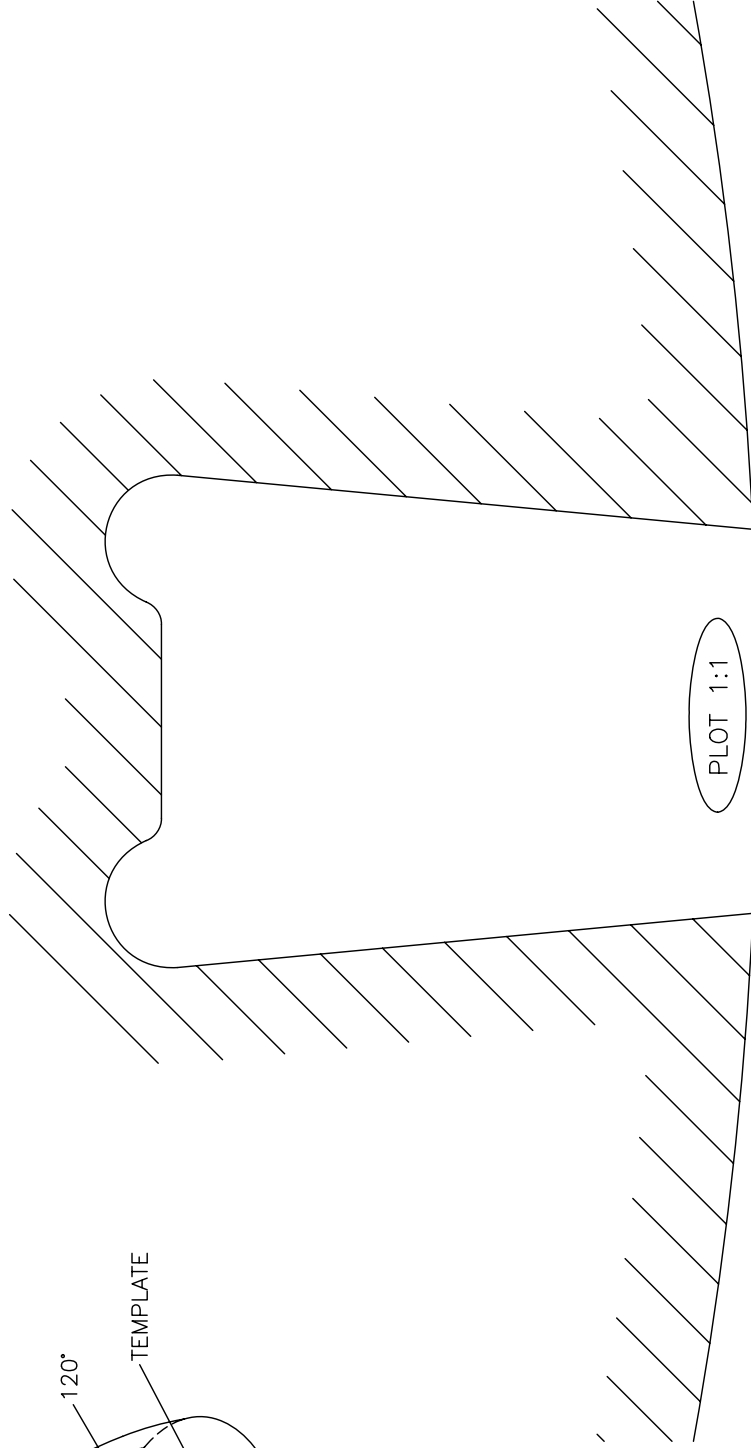
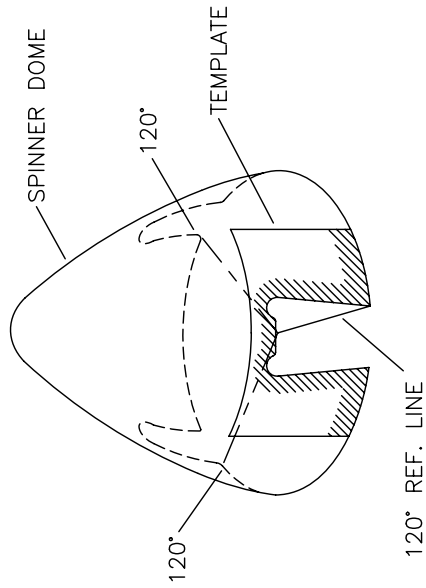

RAMMS S-19 VENTERRA
3-BLADE WARP DRIVE PROP
ROTAX 912ULS - 12" SPINNER TEMPLATE
FIGURE 14-04A

MD5228

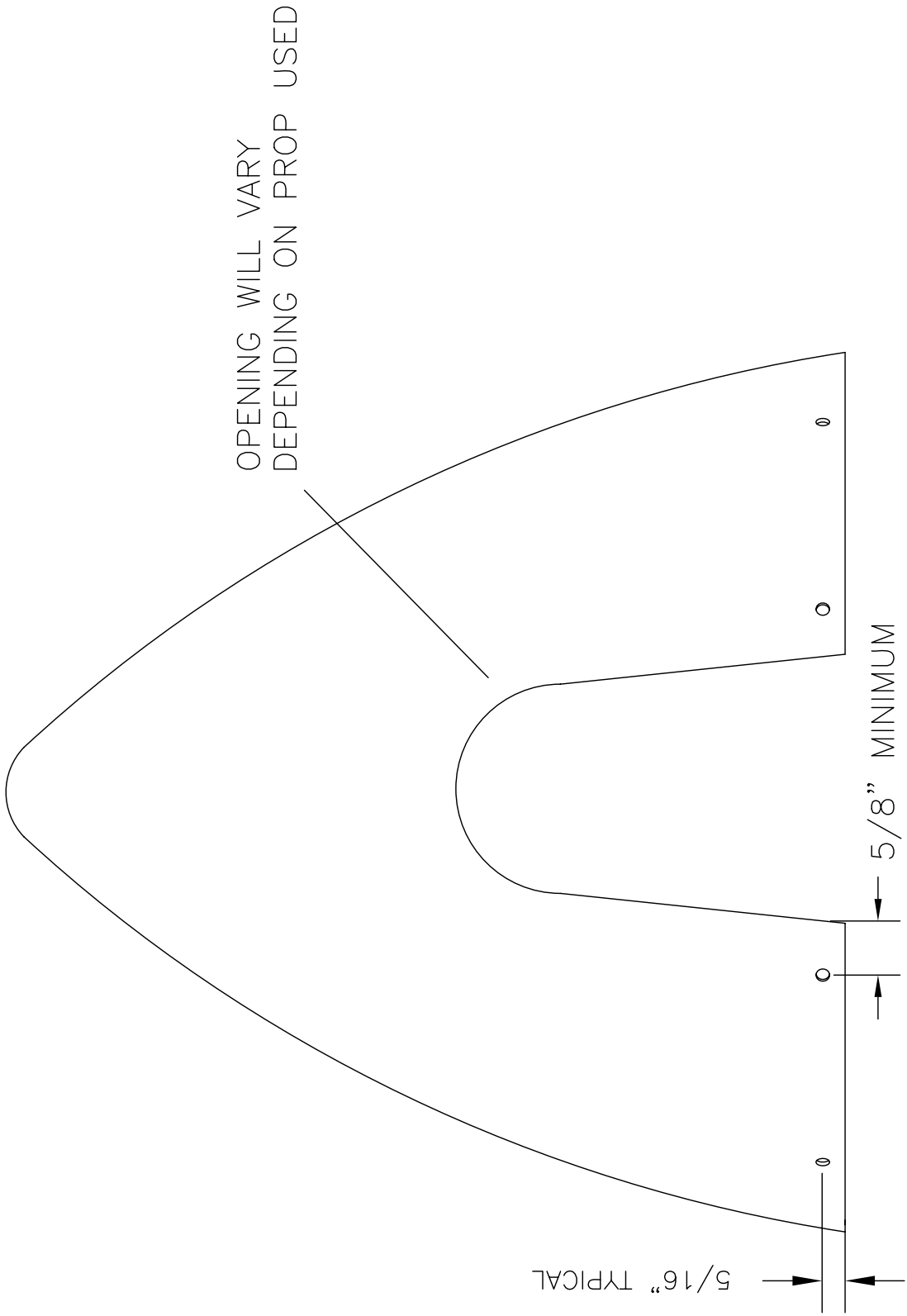

RRR S-19 VENTERRA
SPINNER DRILLING
FIGURE 14-07

MD5228

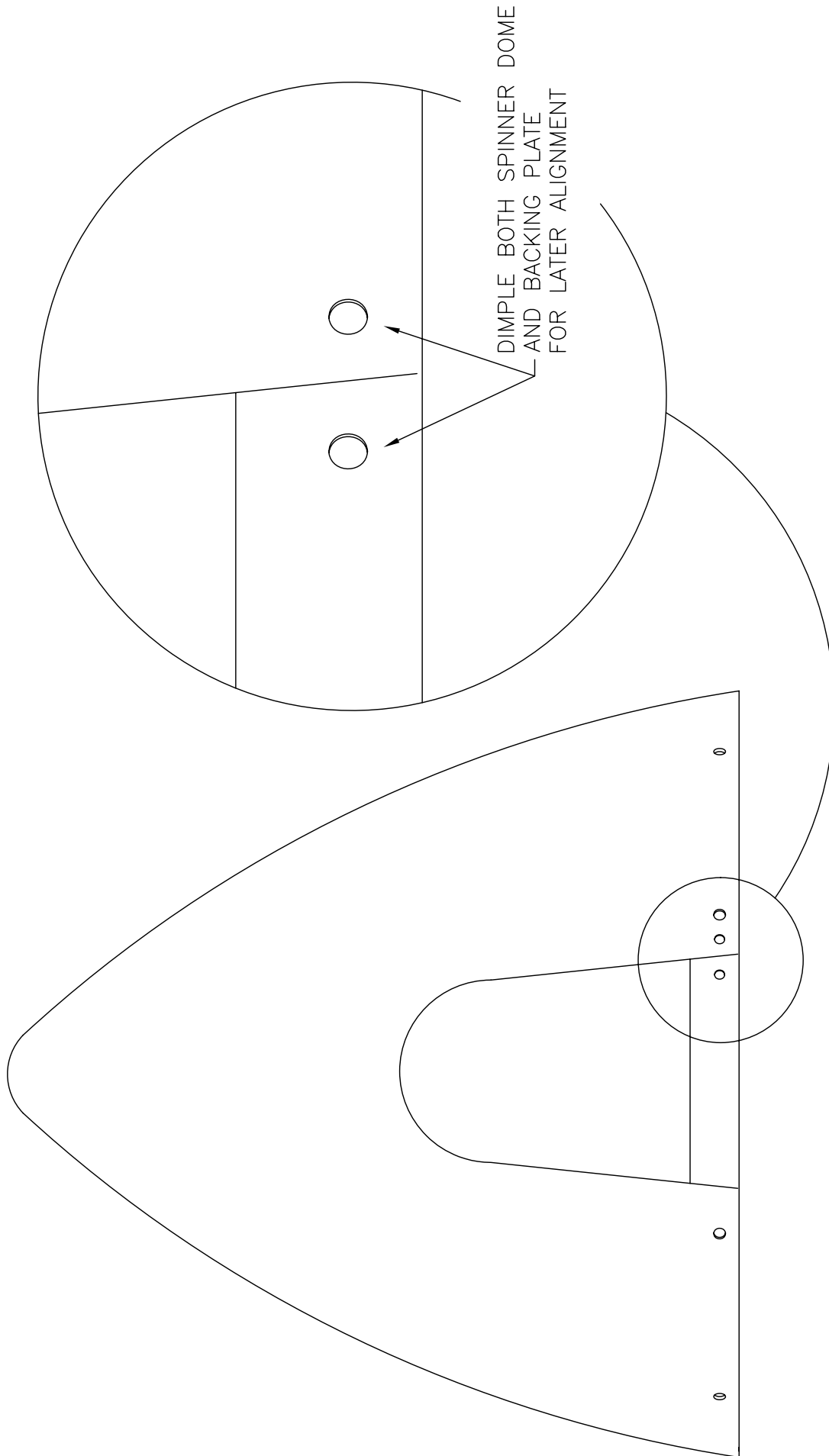

RAMSES S-19 VENTERRA
SPINNER ALIGNMENT MARKS
FIGURE 14-10

MD5228

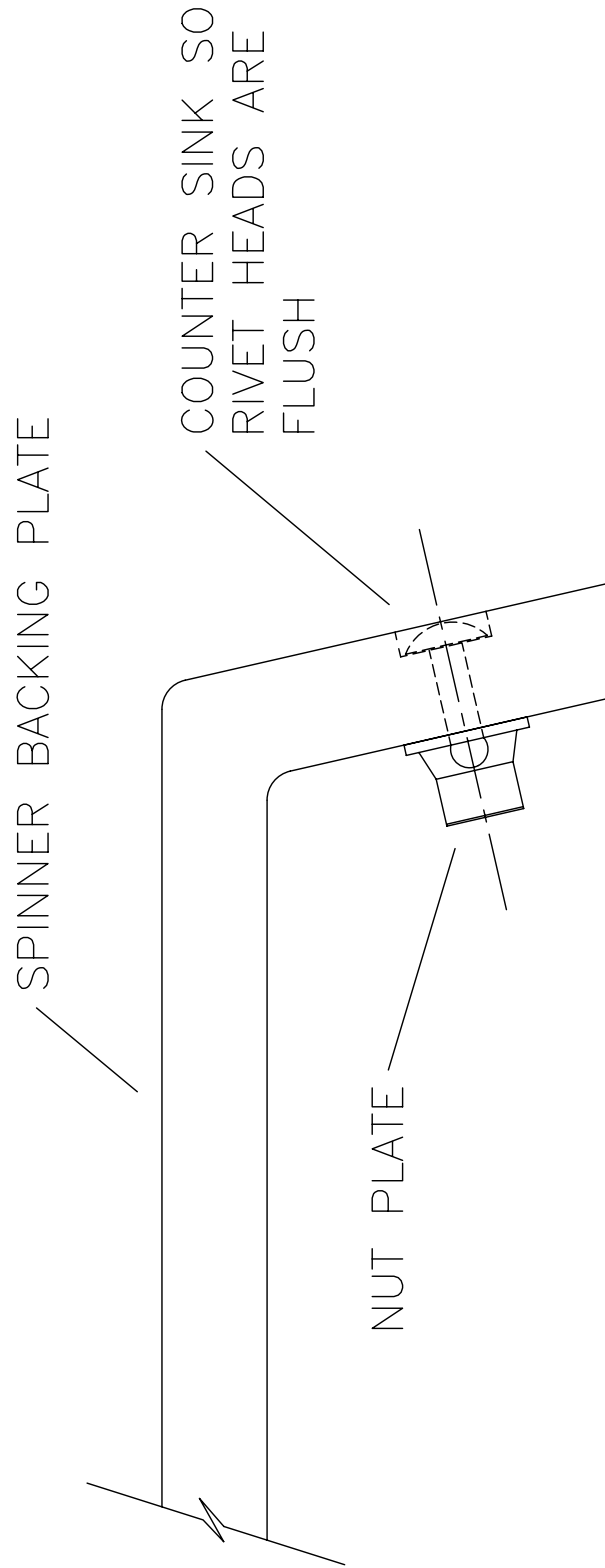

RAMS S-19 VENTERRA
SPINNER NUT PLATE INSTALLATION
FIGURE 14-11

MD5228

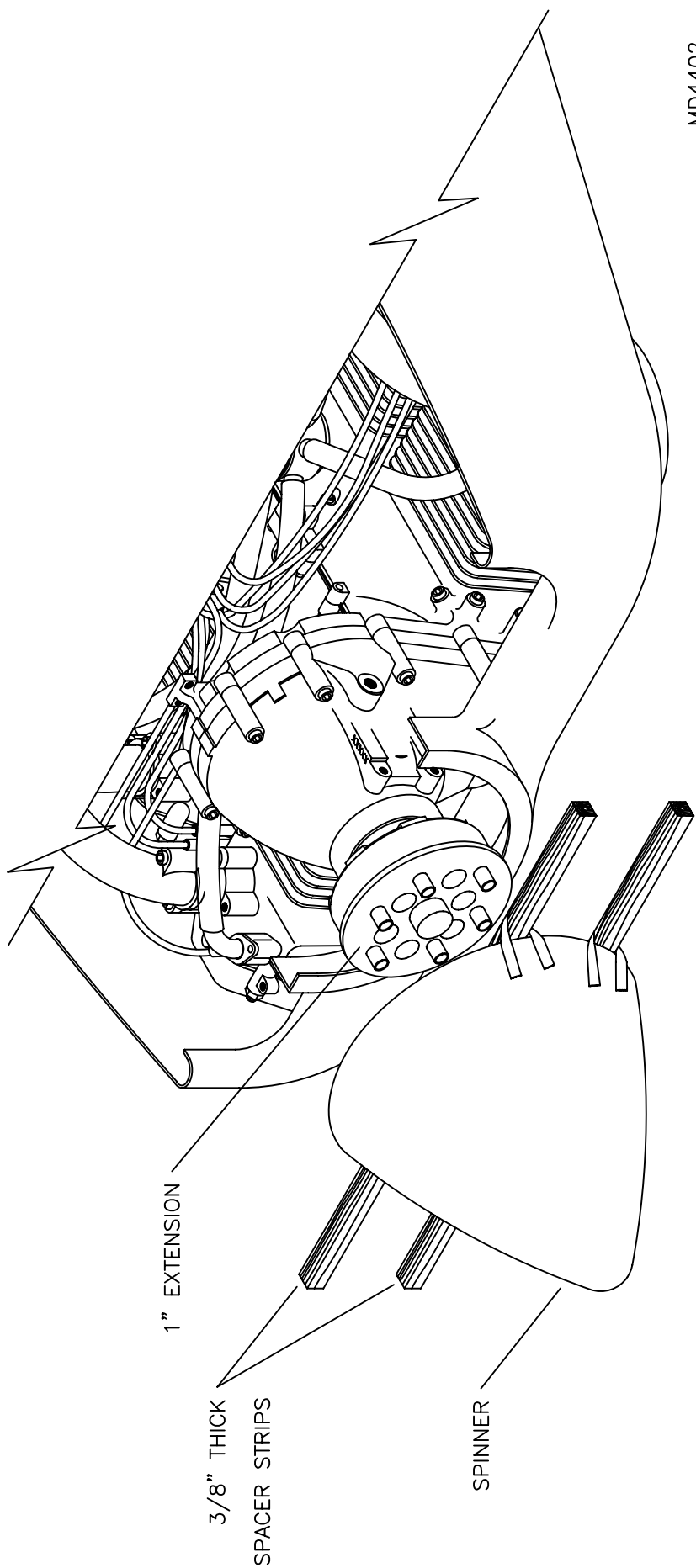

MD4402

IMPORTANT: INSTALLATION OF COWLING REQUIRES ENGINE, PROP EXTENSION AND SPINNER BACKING PLATE TO BE INSTALLED.

RAMS S-19 VENTERRA COWLING TO SPINNER SPACING

FIGURE 14A-02

SPACING IS SYMMETRICAL ABOUT COWLING

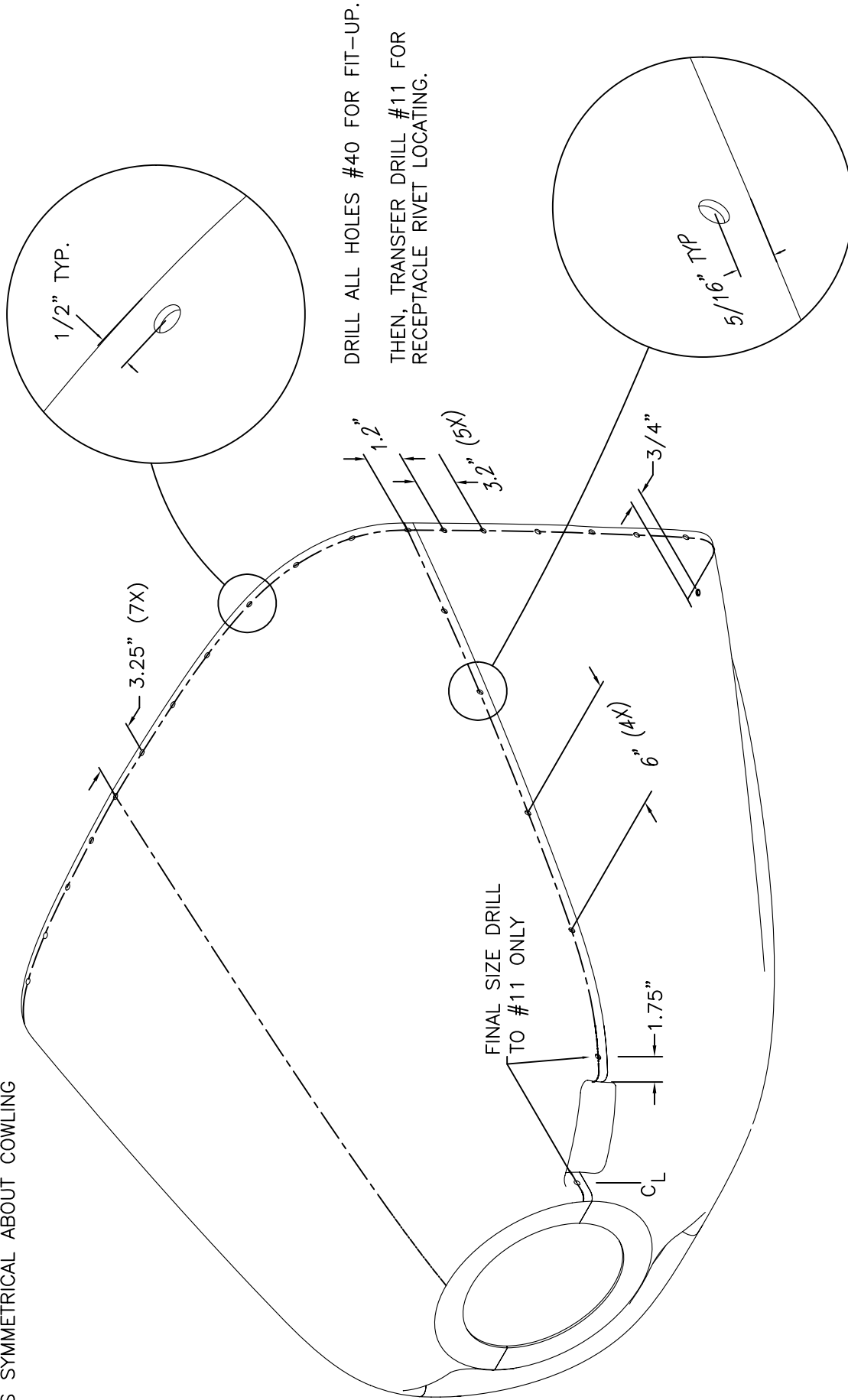

MD5138

RRR S-19 VENTERRA
COWLING FASTENER SPACING
FIGURE 14A-09

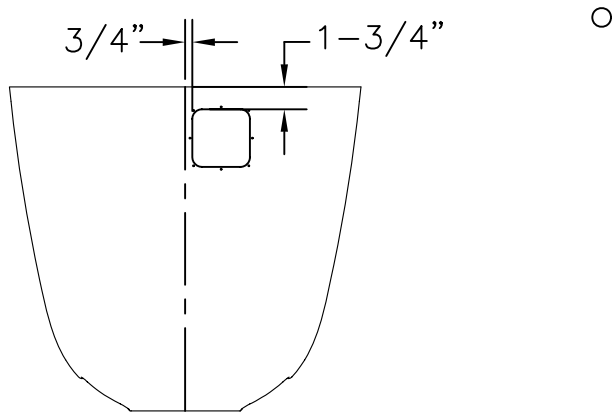
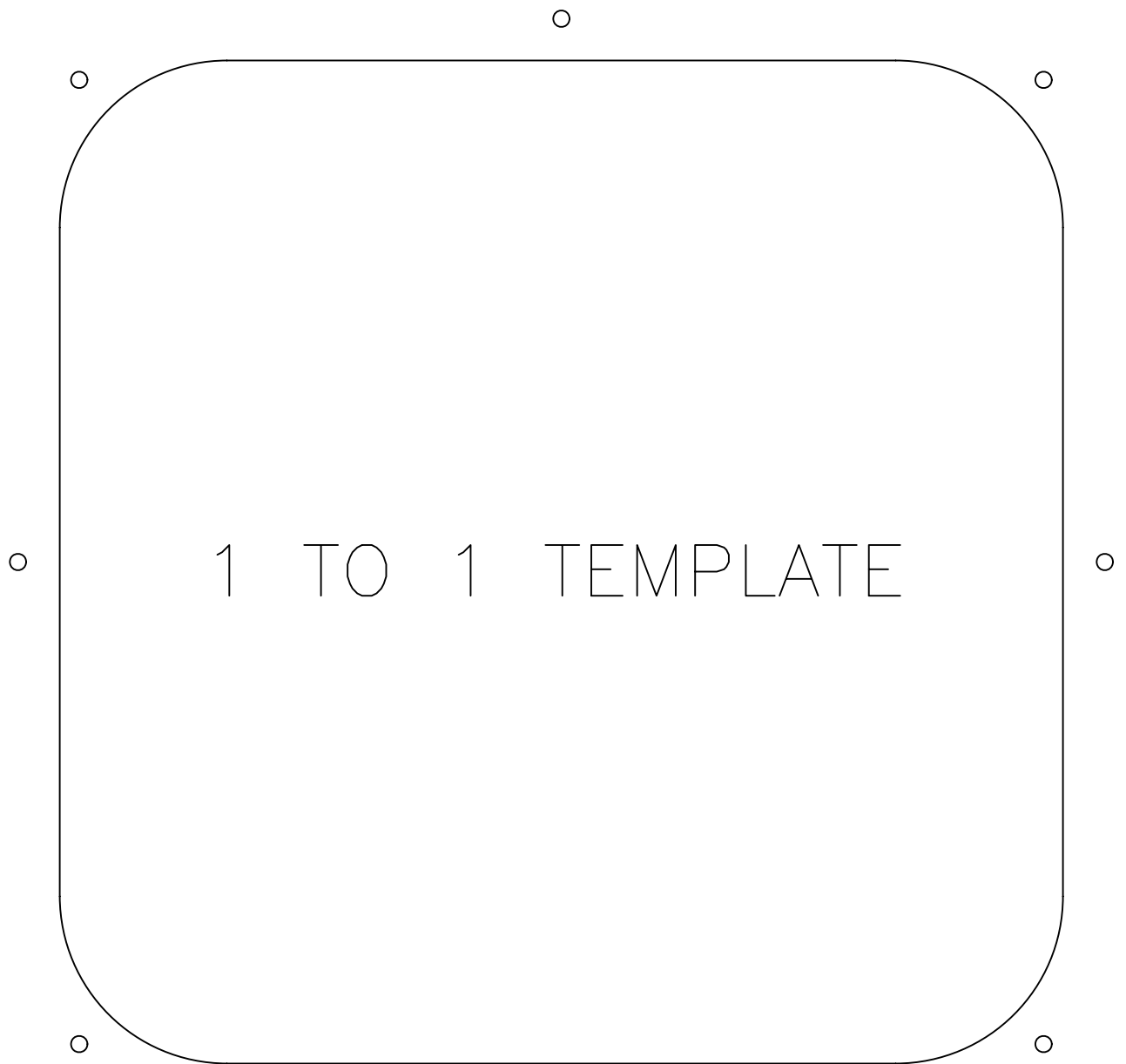

MD5142

MEASUREMENTS AFTER FINAL COWLING TRIM

RANS S-19 VENTERRA
OIL CHECK DOOR TEMPLATE

FIGURE 14A-17

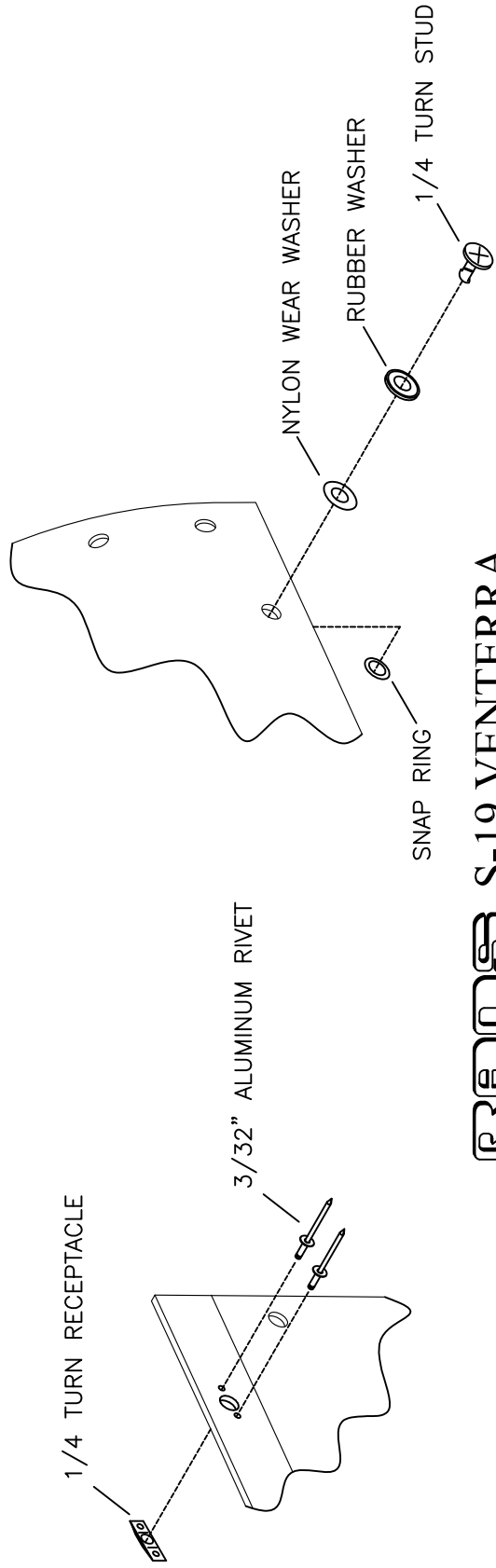
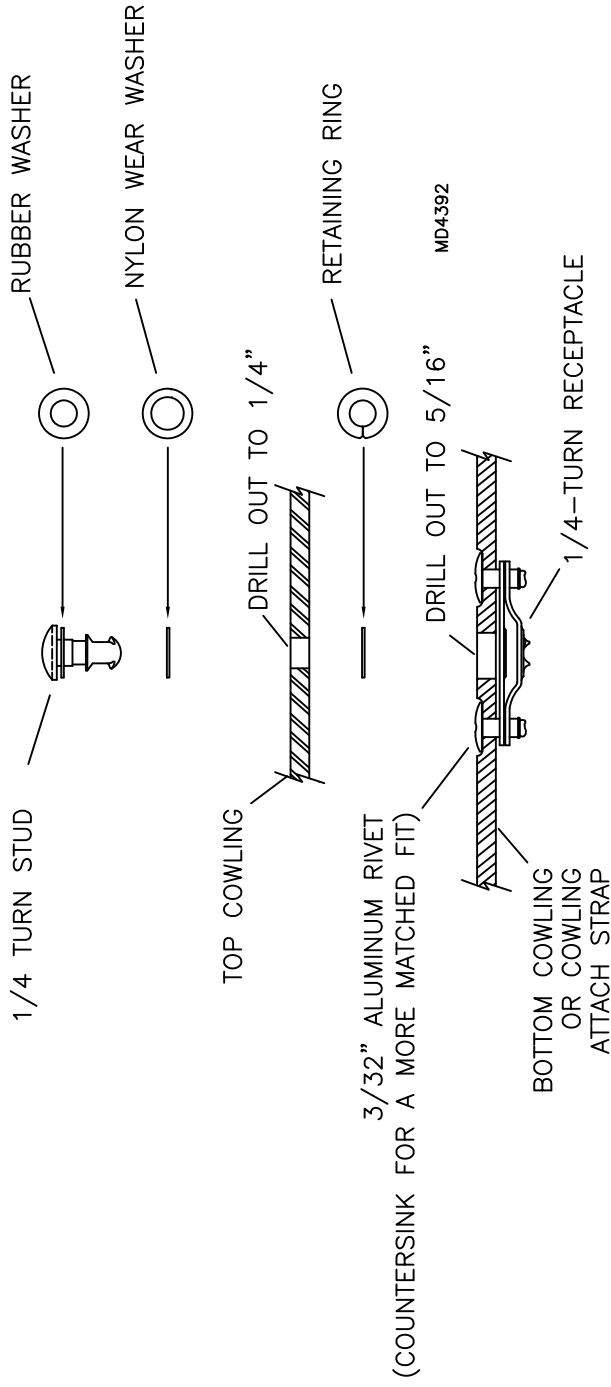

RAMS S-19 VENTERRA
1/4 TURN FASTENER INSTALLATION
FIGURE 14A-22

MD5143