

## 05 – FUSELAGE – CENTER SECTION

BUILDER MODIFIED PARTS .....	05-01
GEAR BLOCK ATTACH .....	05-02
SPAR CARRY-THRU NUT PLATE ORIENTATION .....	05-07
ANGLE GEAR ATTACH MODIFICATION .....	05-13
FLAP MECHANISM REINFORCEMENT PLATE INSTALLATION .....	05A-02
FAIR LEADS MODIFICATION .....	05A-06
REAR SPAR BULKHEAD SUPPORT ANGLE .....	05A-07
REAR SPAR CARRY-THRU RIVET SCHEDULE .....	05A-08
FUSELAGE SIDE SKIN BENDING .....	05B-01
FUSELAGE SIDE SKIN BENDING DETAIL .....	05B-01A
CABIN SIDE SKIN MODIFICATION .....	05B-02
STIFFENERS AND STRINGERS JOGGLES .....	05B-03
STIFFENERS AND STRINGERS JOFFLE METHOD .....	05B-03A
RIB – CABIN WALL MODIFICATION .....	05B-04
RIB – CABIN WALL MODIFICATION .....	05B-04A
CLIP MODIFICATION .....	05B-05
LONGERON MODIFICATION .....	05B-08
FORWARD LONGERON MODIFICATION .....	05B-08A
GUSSET MODIFICATION .....	05B-11
BELLY SKIN – CABIN MIDDLE ORIENTATION .....	05B-13
SIDE SKIN MIDIFICATION .....	05C-04
FUSELAGE CENTER SECTION – RIVET SCHEDULE .....	05C-06
FUSELAGE CENTER SECTION – RIVET SCHEDULE .....	05C-06A

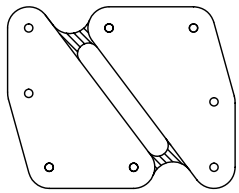

KPFU0570

MODIFY PARTS AS SHOWN BY REMOVING HATCHED AREAS. PARTS ARE NOT SHOWN FULL SIZE.

MARK PARTS AS NEEDED FOR LATER IDENTIFICATION.

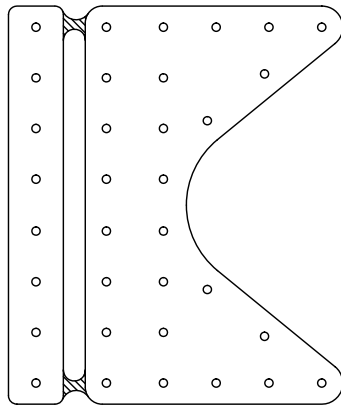

KPFU0525

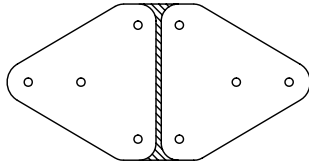

KPIP0099

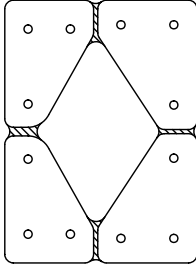

KPFU0567

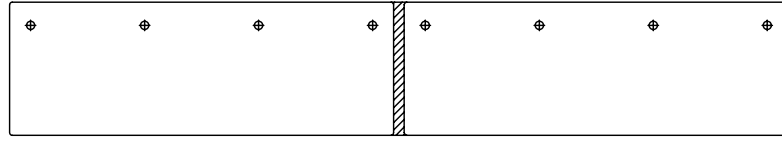

KPFU0584

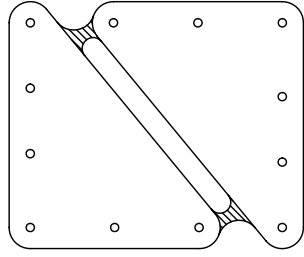

KPFU0571



KPFU0501

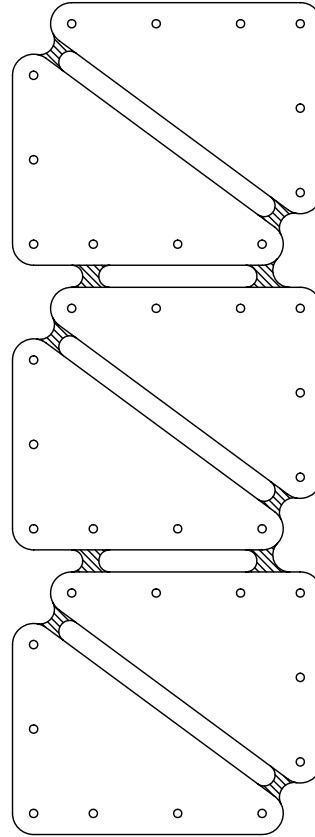

KPFU0421

MD5049

# RAMS S-19 VENTERRA BUILDER MODIFIED PARTS FIGURE 05-01

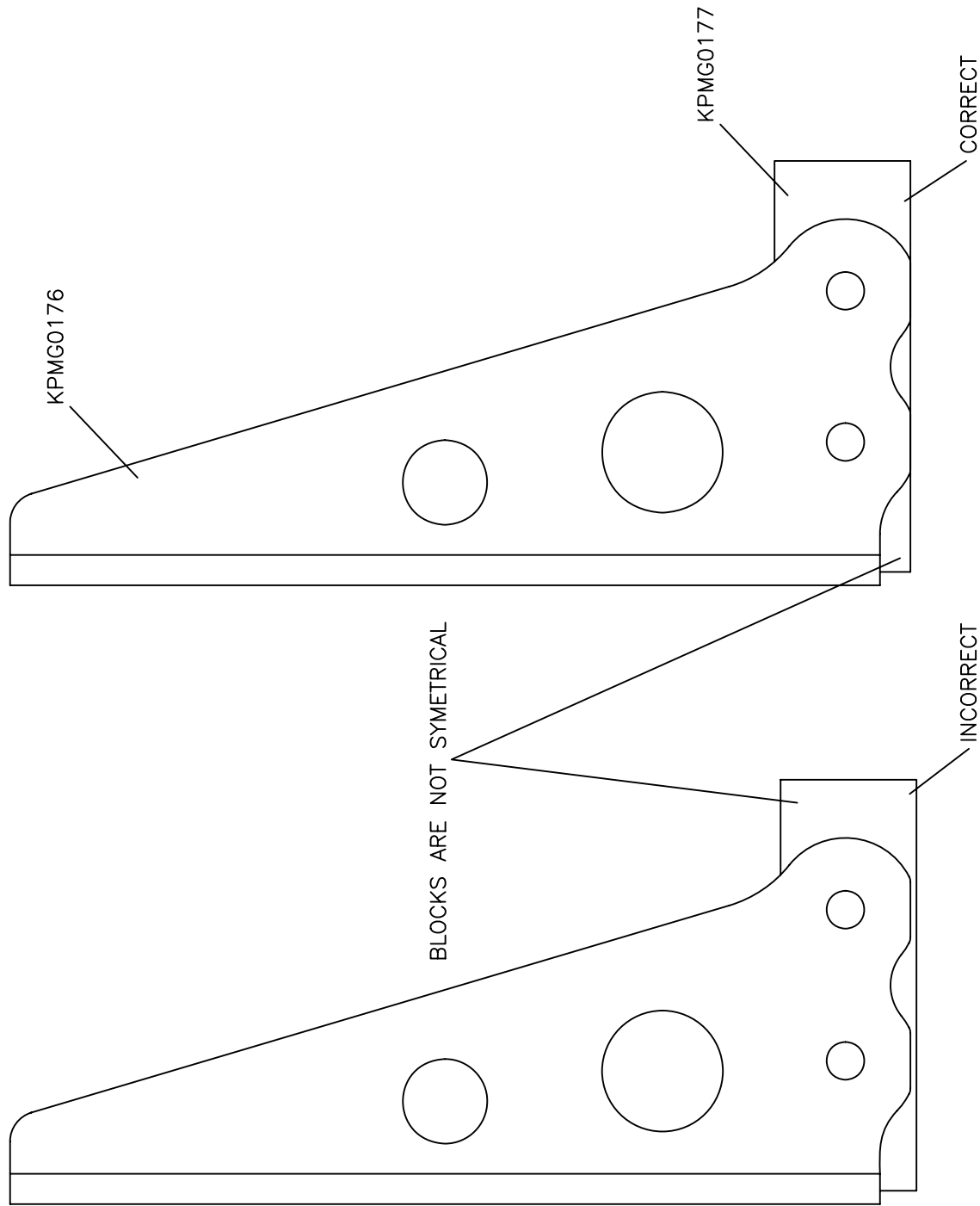

MD5014

**RRMO S-19 VENTERRA**  
**GEAR BLOCK ATTACH**  
**FIGURE 05-02**

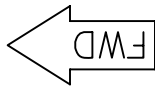

TRANSFER DRILL 1/4"  
(12 PLACES)

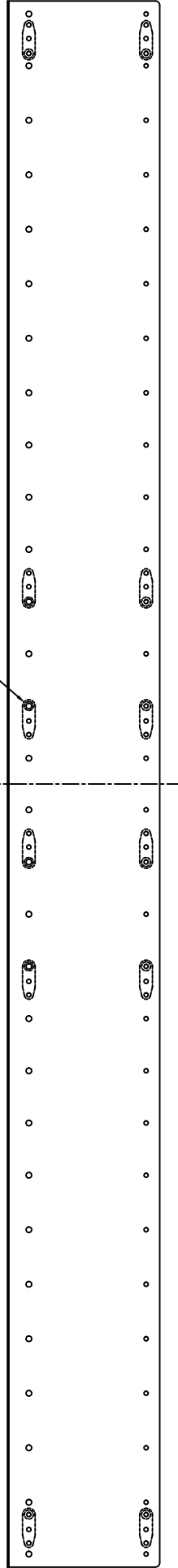

MD5238

04/01/2011

**RAMSES** S-19 VENTERRA  
SPAR CARRY-THRU NUT PLATE ORIENTATION  
FIGURE 05-07

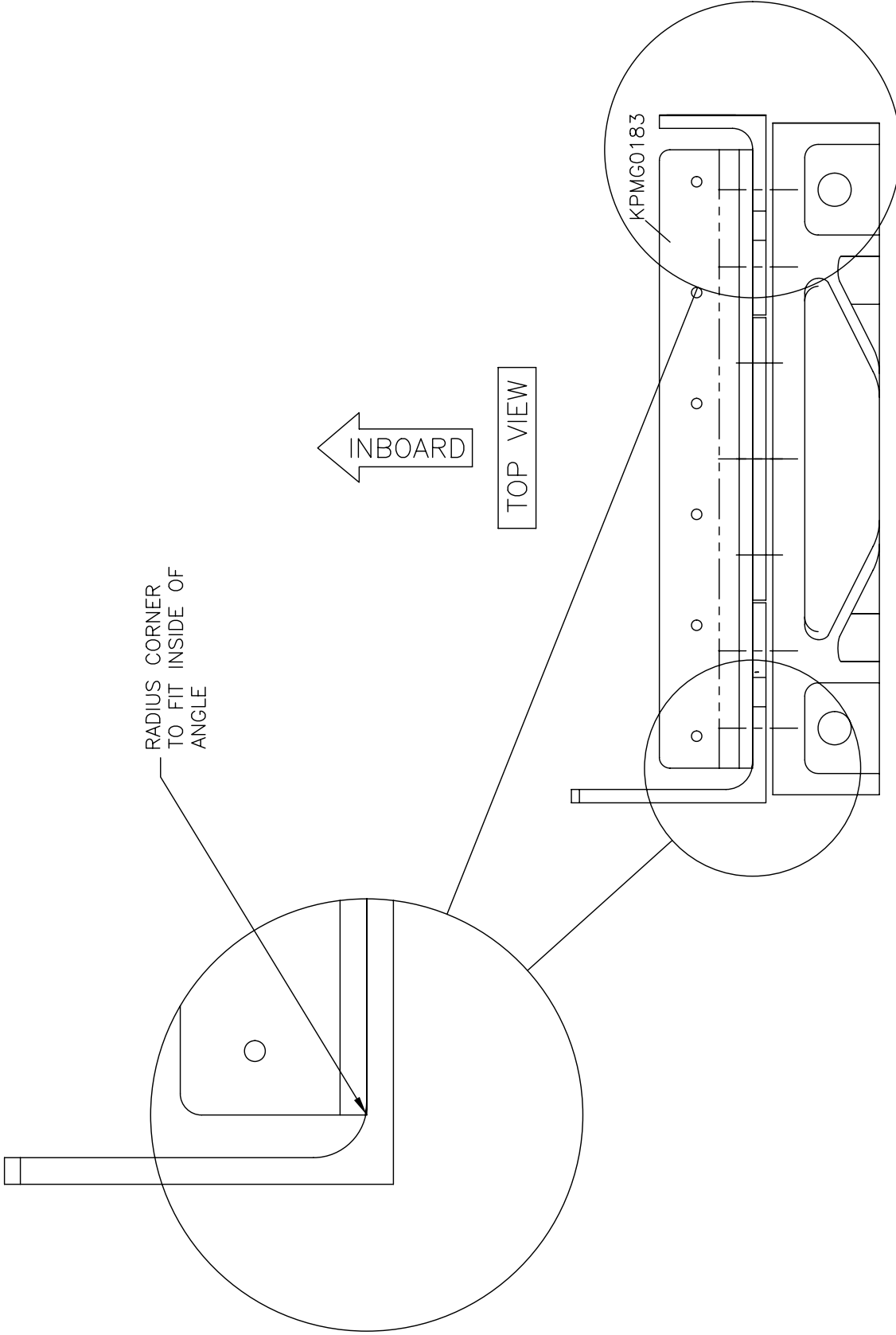

MD4812

**RRAMES S-19 VENTERRA**  
**ANGLE GEAR ATTACH MODIFICATION**  
**FIGURE 05-13**

3. DRILL #40 THROUGH SEAT RIB & REINFORCEMENT PLATE.
4. REMOVE REINFORCEMENT PLATE.
5. DRILL #40 HOLES IN PLATE TO #11 FOR RIVET CLEARANCE.

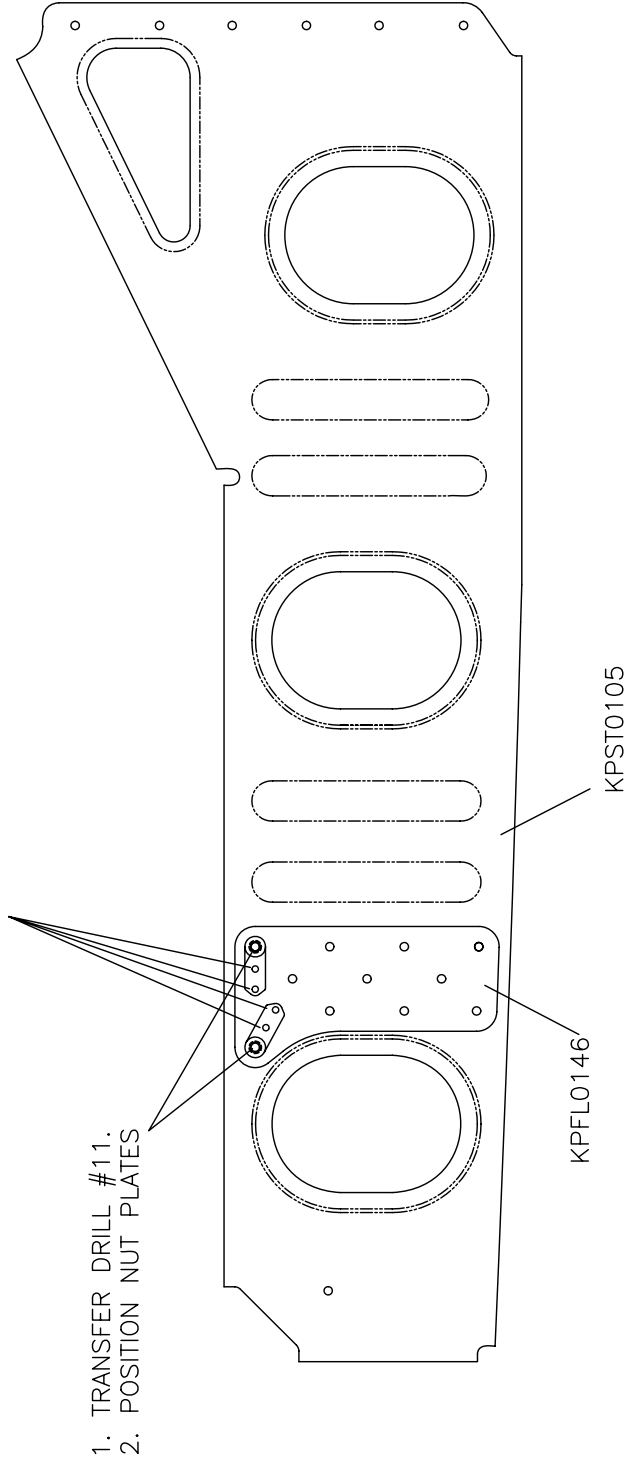

MD5452

**RAMS S-19 VENTERRA**  
**FLAP MECHANISM REINFORCEMENT PLATE INSTALLATION**  
**FIGURE 05A-02**

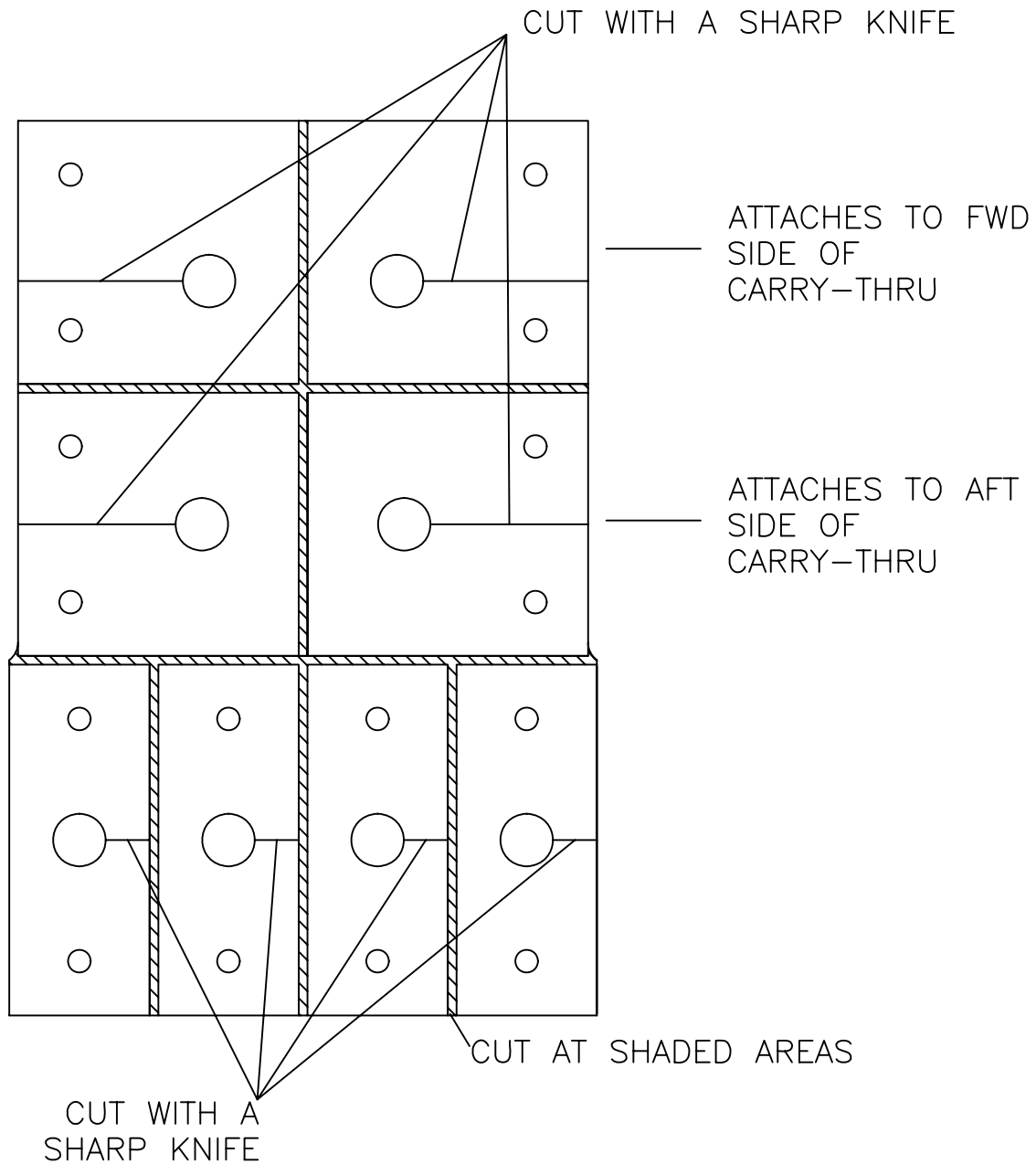

CUT APART AS SHOWN

1:1

**RANS S-19 VENTERRA  
FAIR LEADS MODIFICATION  
FIGURE 05A-06**

MD5074

04/01/2011

LEFT AND RIGHT REQ'D (LH SHOWN)

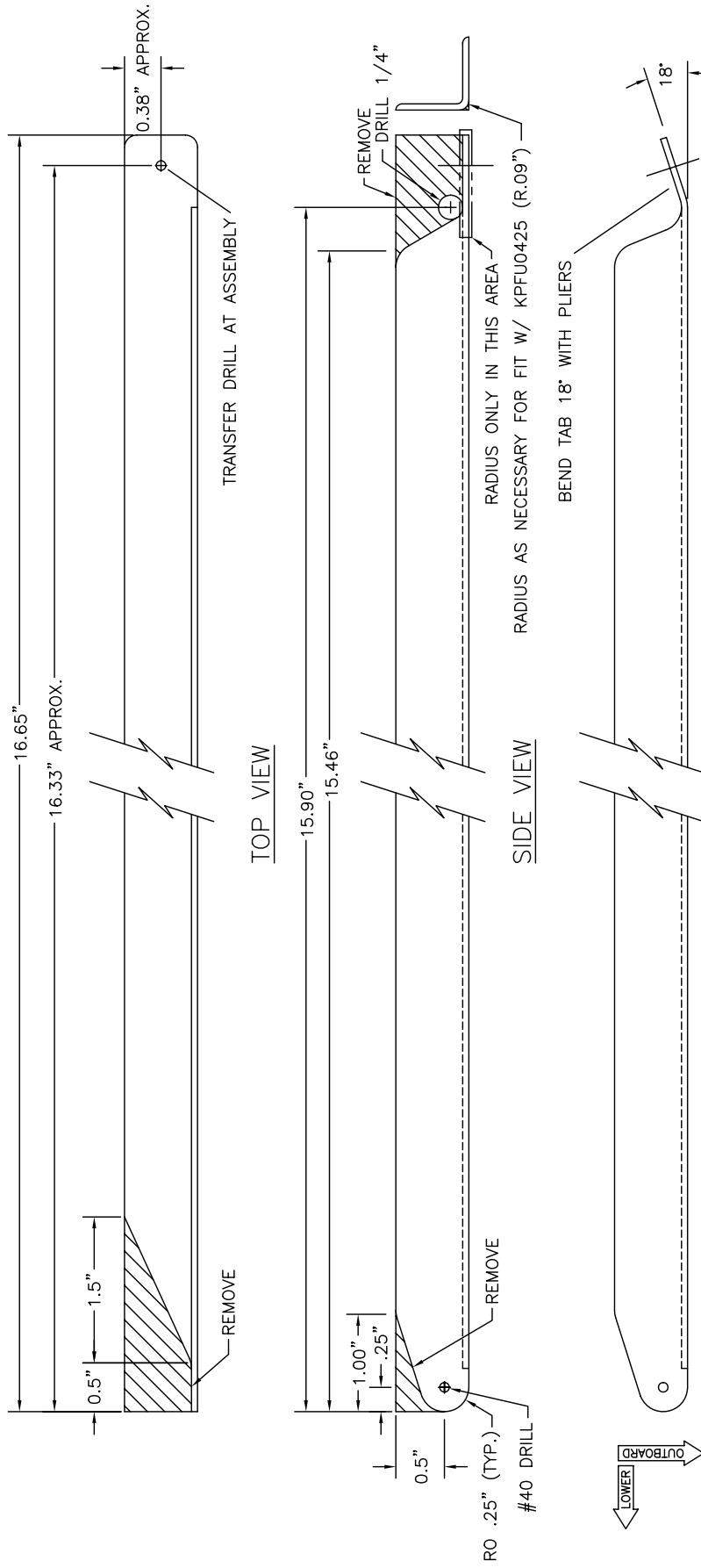

MD5115

**RRF S-19 VENTERRA**  
**REAR SPAR BULKHEAD SUPPORT ANGLE**  
**FIGURE 05A-07**



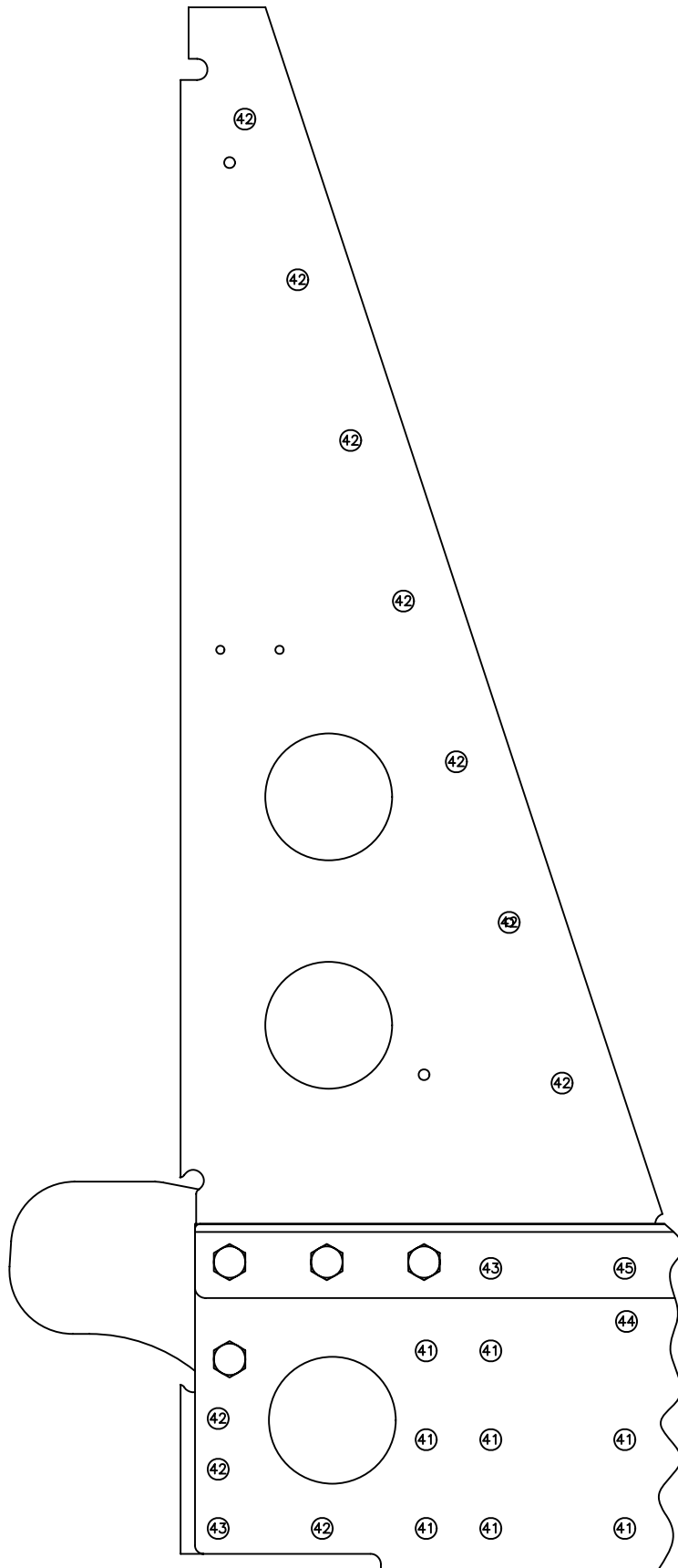

ALL RIVETS CCPQ-XX

MD5234

**RANS S-19 VENTERRA**  
**REAR SPAR CARRY-THRU RIVET SCHEDULE**

FIGURE 05A-08

04/01/2011

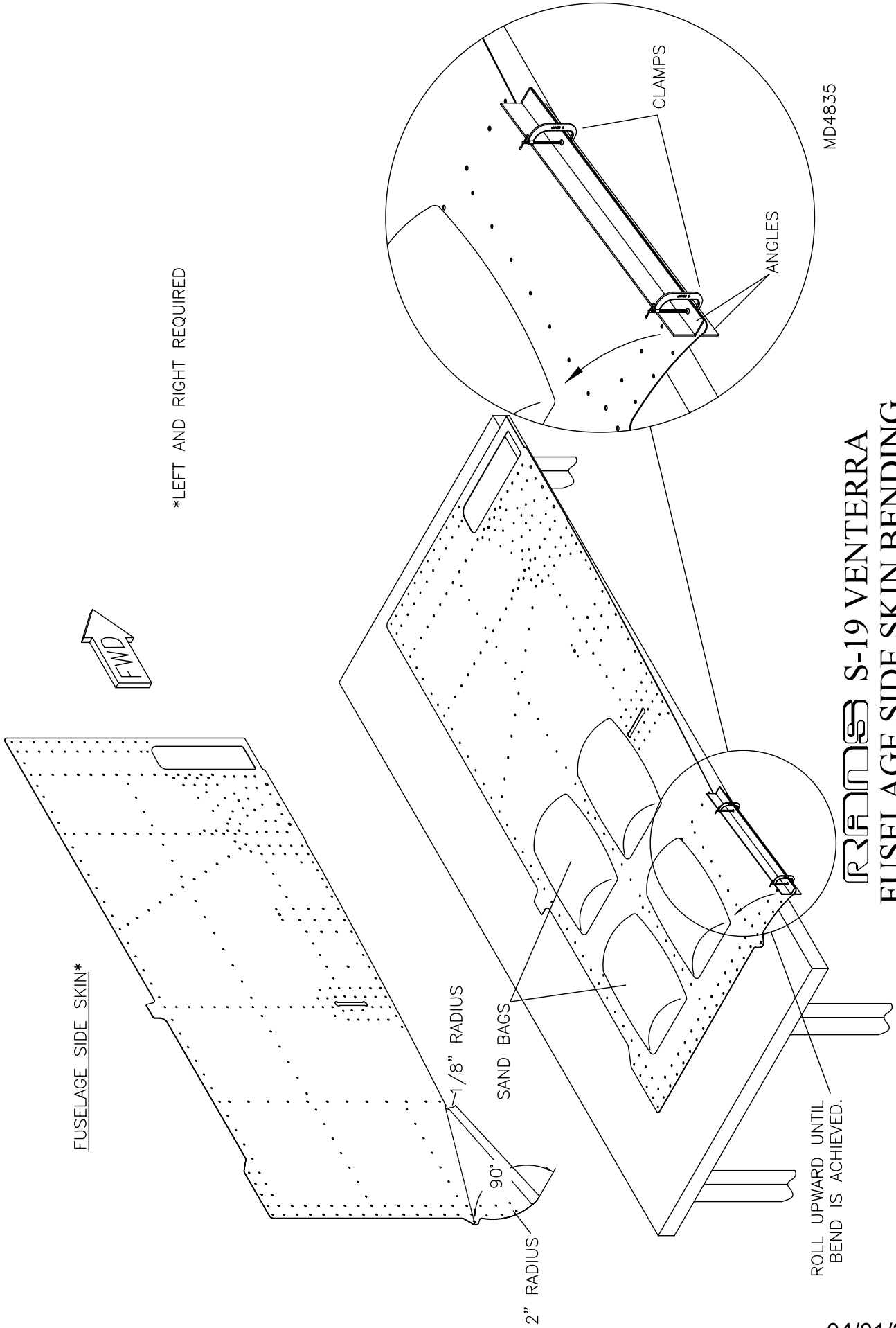

MD4835

**RRANES S-19 VENTERRA**  
**FUSELAGE SIDE SKIN BENDING**  
**FIGURE 05B-01**

ROLL UPWARD UNTIL  
 BEND IS ACHIEVED.

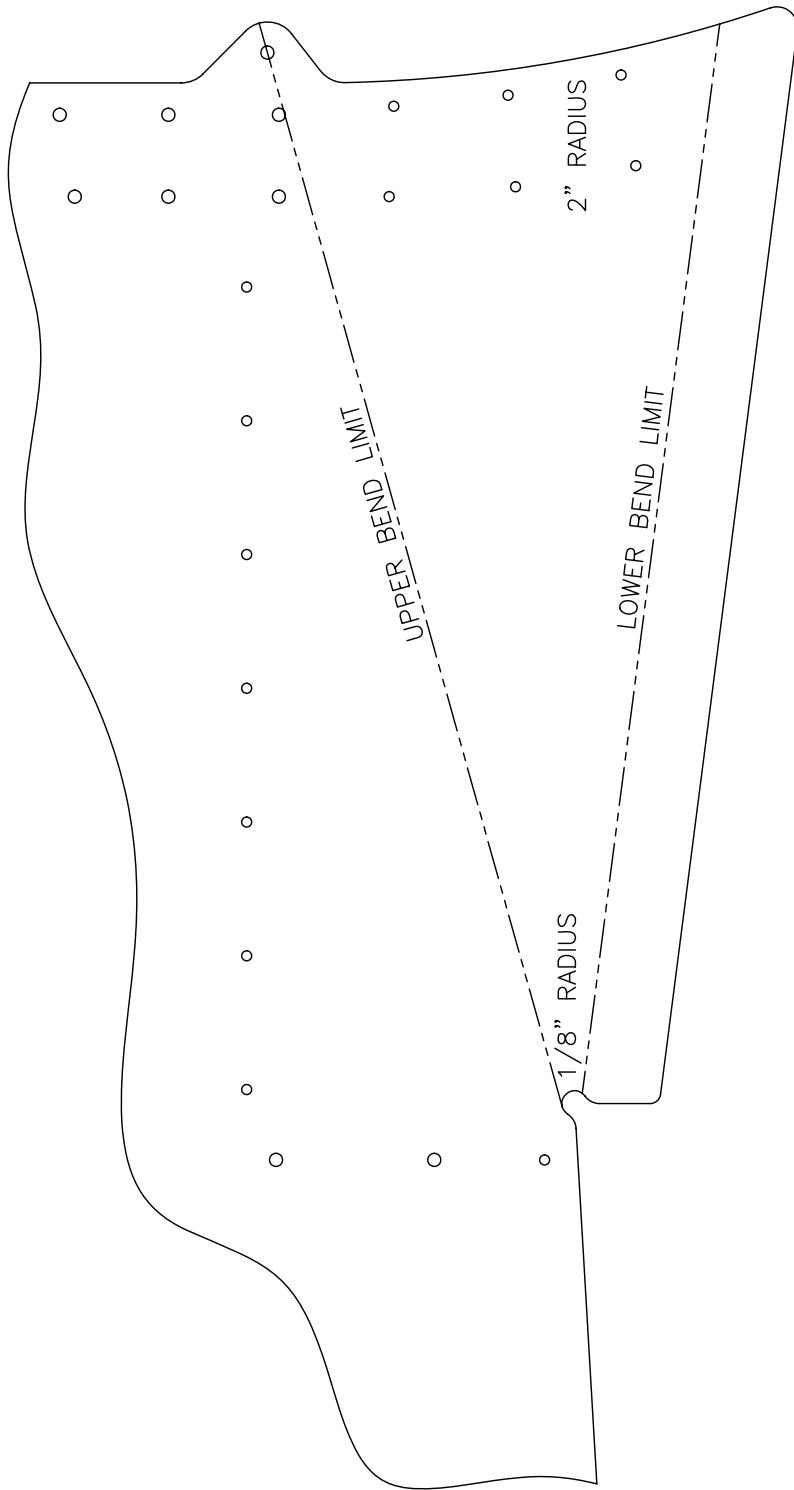

MD4835

**RRF** S-19 VENTERRA  
 FUSELAGE SIDE SKIN BENDING DETAIL  
 FIGURE 05B-01A

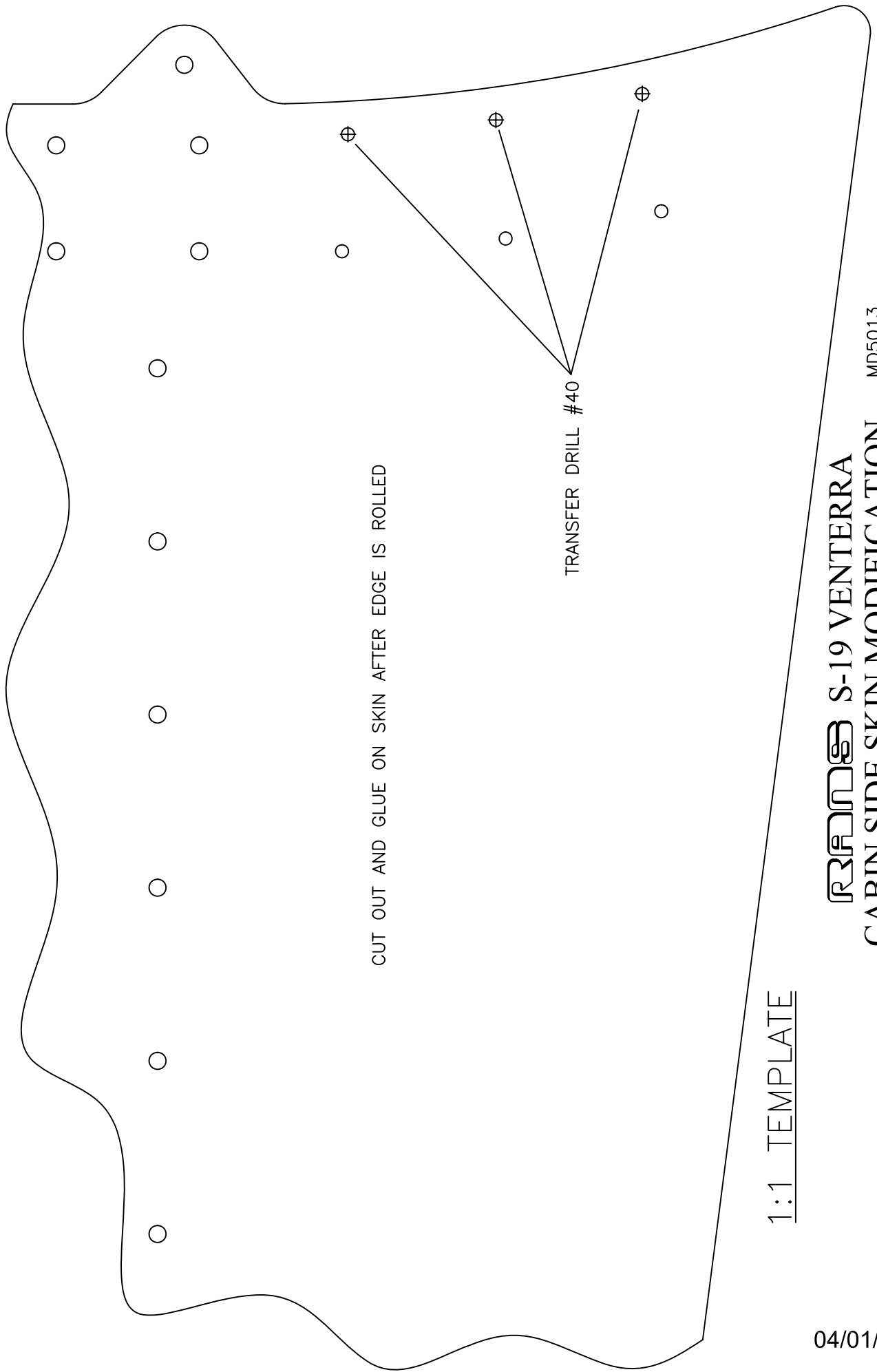

CUT OUT AND GLUE ON SKIN AFTER EDGE IS ROLLED

TRANSFER DRILL #40

1:1 TEMPLATE

**RRR** S-19 VENTERRA  
CABIN SIDE SKIN MODIFICATION  
FIGURE 05B-02

MD5013

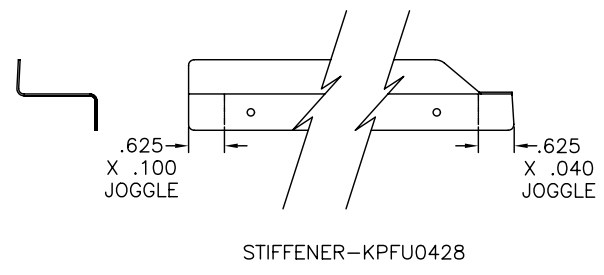
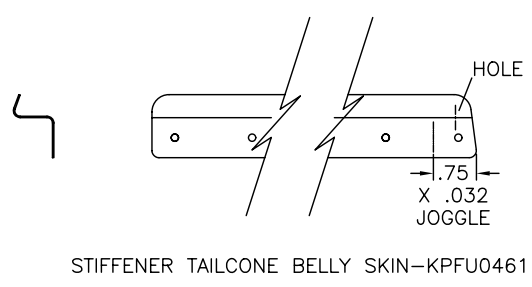
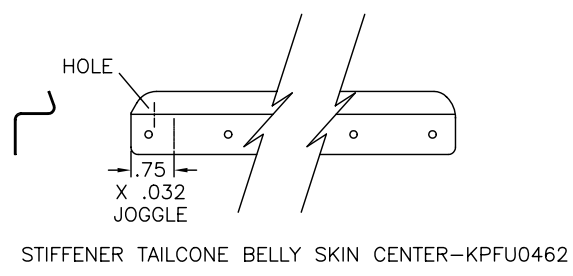
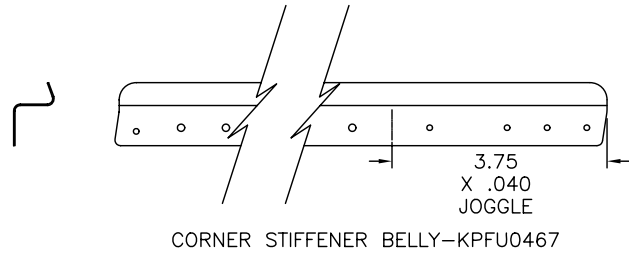
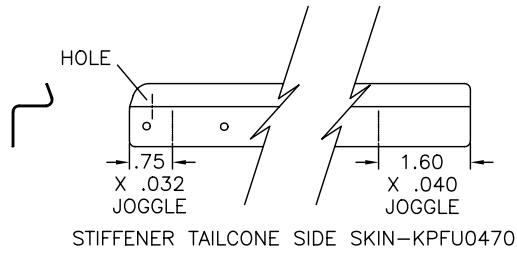

MD4843

**RANS S-19 VENTERRA**  
**STIFFENERS AND STRINGERS JOGGLES**  
**FIGURE 05B-03**

04/01/2011

\*FABRICATE 1 FROM 0.050" AND 1 FROM 0.100" ALUMINUM SHEET

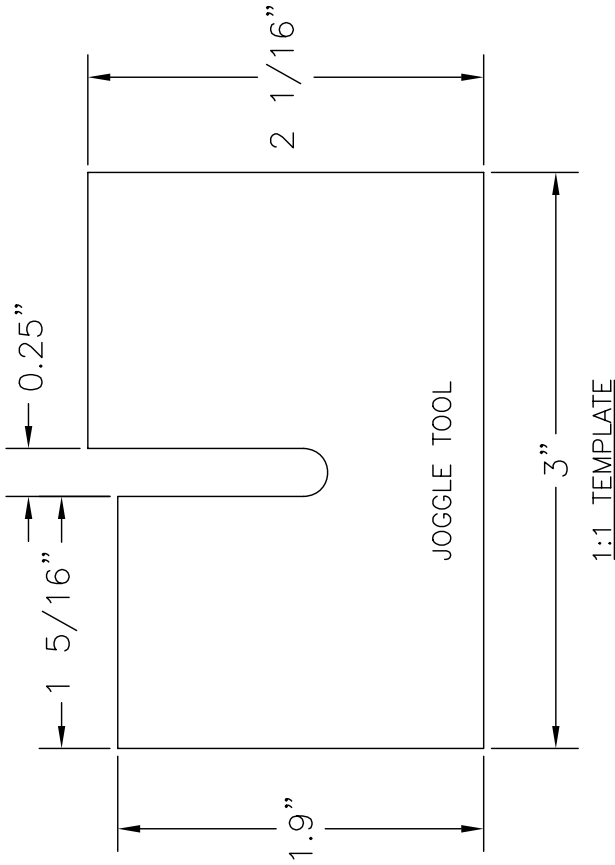

\*USE THE 0.050" TOOL FOR 0.032" AND 0.040" JOGGLES AND THE 0.100" FOR 0.100" JOGGLES.

HINT: TO MAKE JOGGLE MORE PRONOUNCED TAPE A PIECE OF SCRAP .100" MATERIAL ON ONE OR BOTH JAWS OF THE VICE.

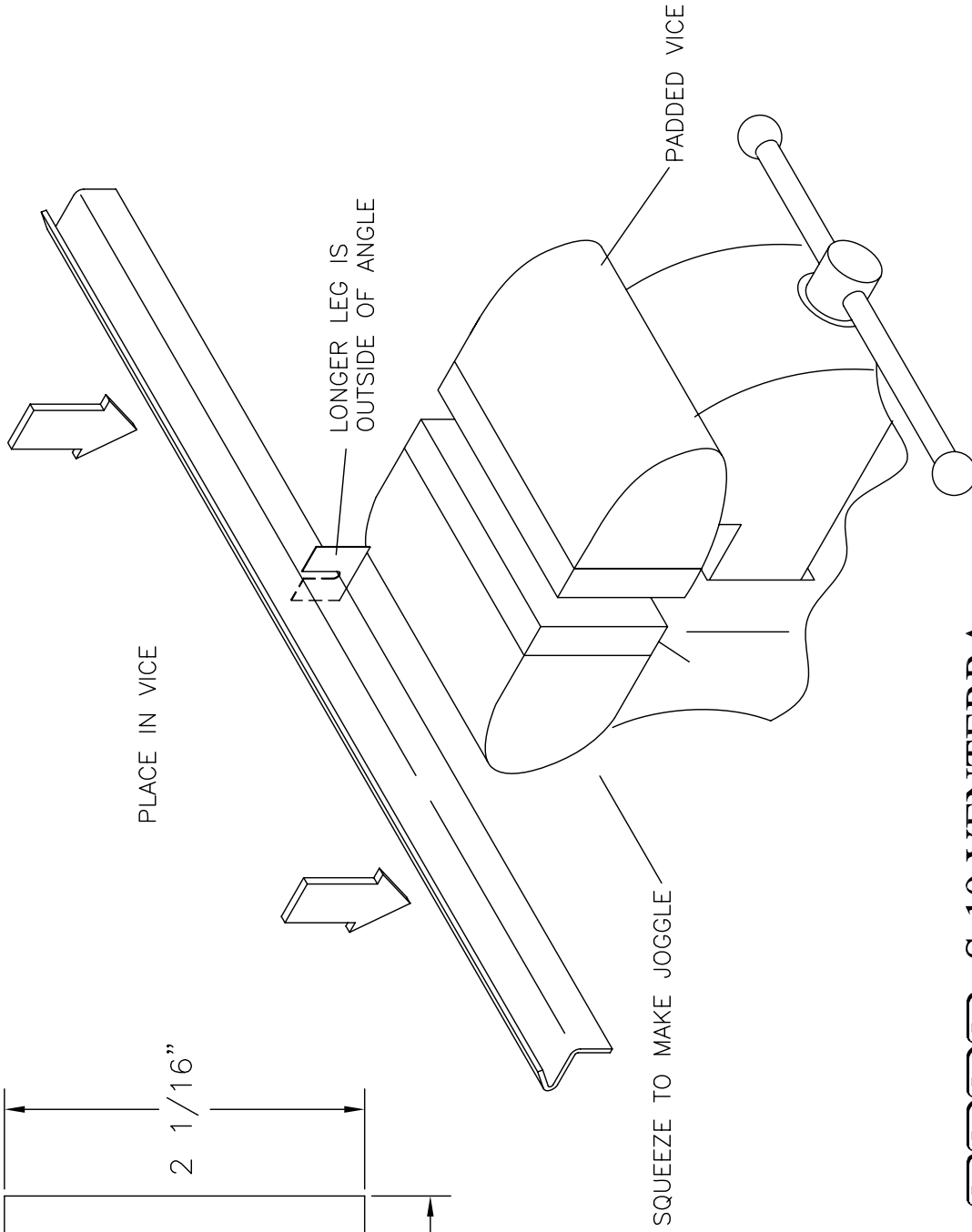

# RRR S-19 VENTERRA STIFFENERS AND STRINGERS JOGGLE METHOD

FIG. 05B-03A

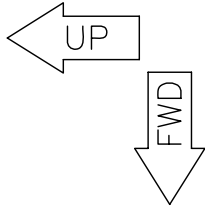
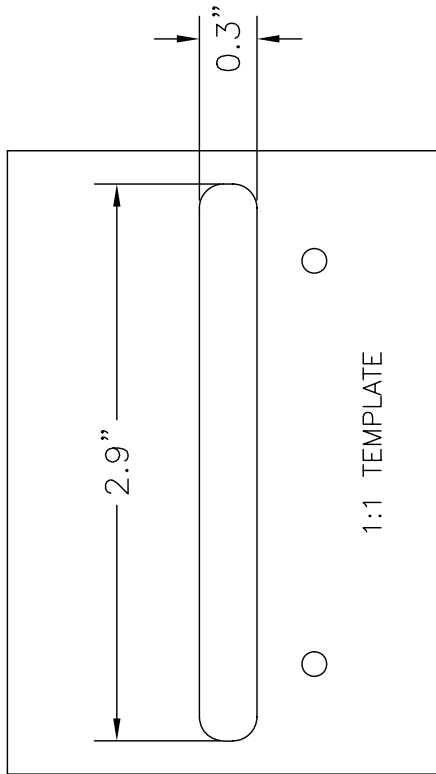

MARK OUTLINE OF SLOT AND REMOVE TEMPLATE.  
 DRILL CORNERS #11. FINISH  
 SLOT WITH ROTARY TOOL.

CUT OUT

RIB - CABIN SIDE WALL  
 (KPFU0422-L/R)

CLECO

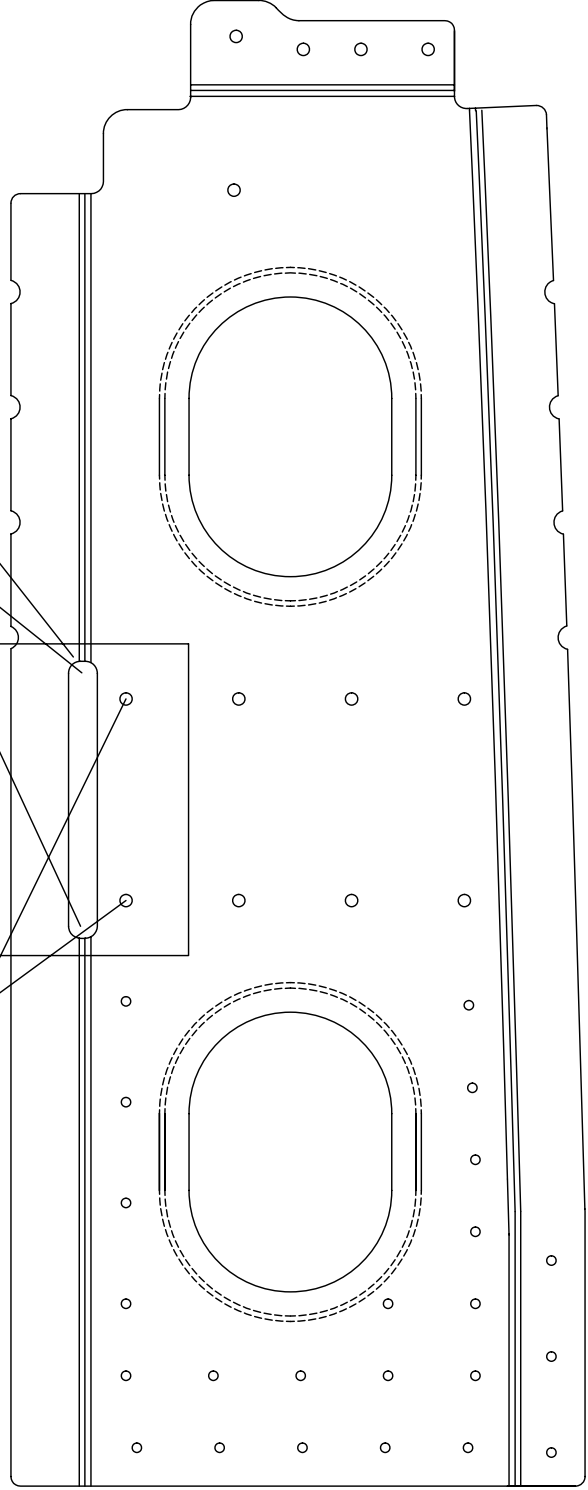

**RRR S-19 VENTERRA**  
**RIB-CABIN WALL MODIFICATION**  
**FIGURE 05B-04**

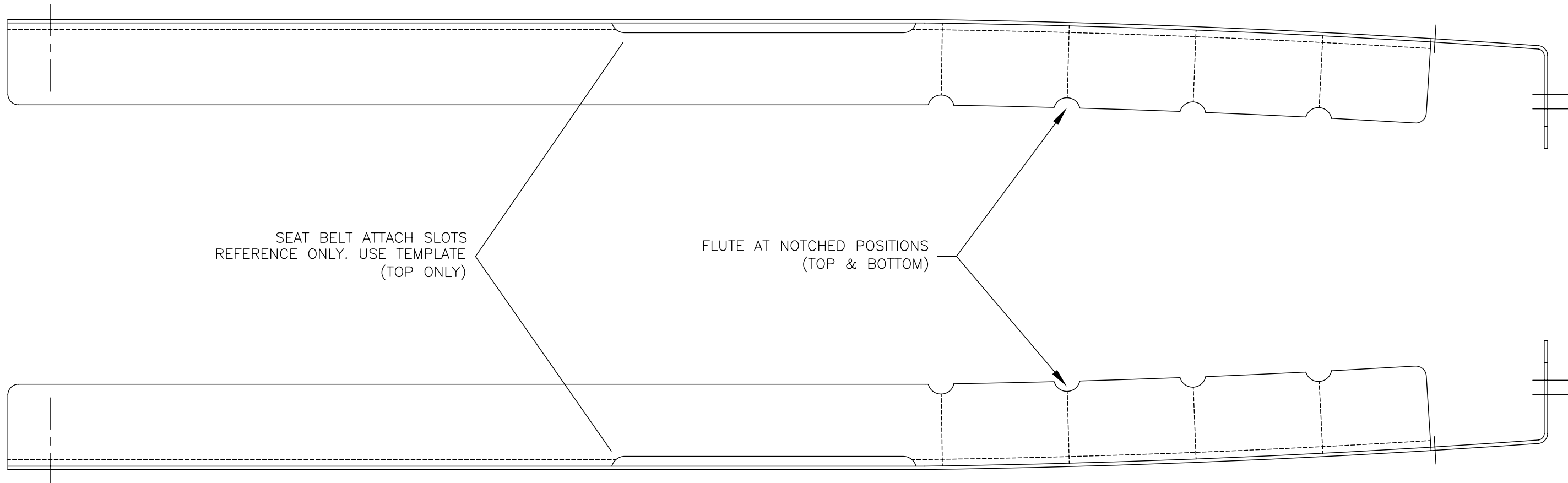

SEAT BELT ATTACH SLOTS  
REFERENCE ONLY. USE TEMPLATE  
(TOP ONLY)

FLUTE AT NOTCHED POSITIONS  
(TOP & BOTTOM)

BUILDER FORMS TO MATCH FULL SIZE DRAWING  
KPFU0422L/R

1:1 TEMPLATE

MD4856

**RAMS S-19 VENTERRA**  
**RIB - CABIN WALL MODIFICATION**  
**FIGURE 05B-04A**

04/01/2011



CUT 2 PARTS  
MAKING 4 PARTS

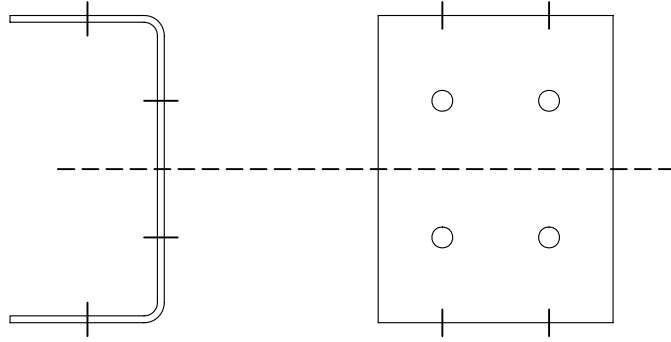

KPFU0520

MD5009

**RAMS** S-19 VENTERRA  
CLIP MODIFICATION  
FIGURE 05B-05

TRY FIRST ON SCRAP PIECE OF METAL  
MOVE MATERIAL IN 1/8" INCREMENTS TO ACHIEVE GRADUAL BEND  
VERIFY AGAINST TEMPLATE EVERY INCH  
BEND A RIGHT AND LEFT HAND PART.

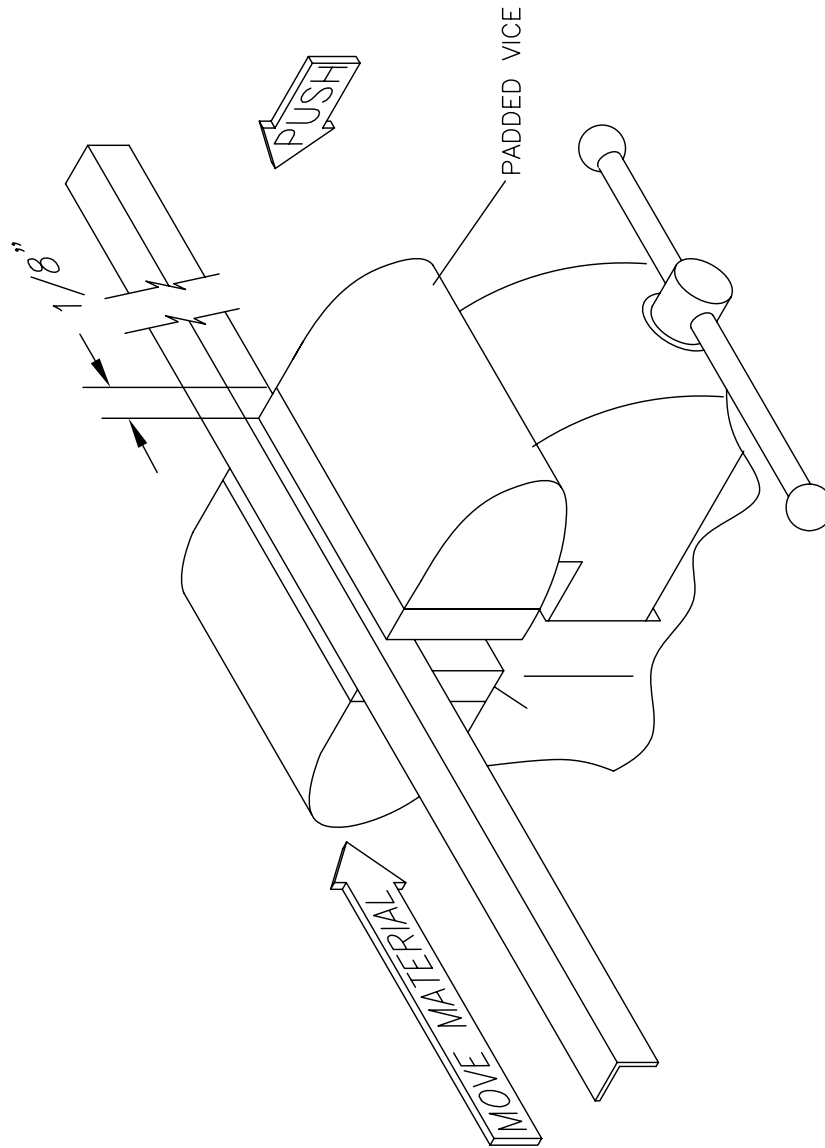

**RRR** S-19 VENTERRA  
LONGERON MODIFICATION  
FIGURE 05B-08

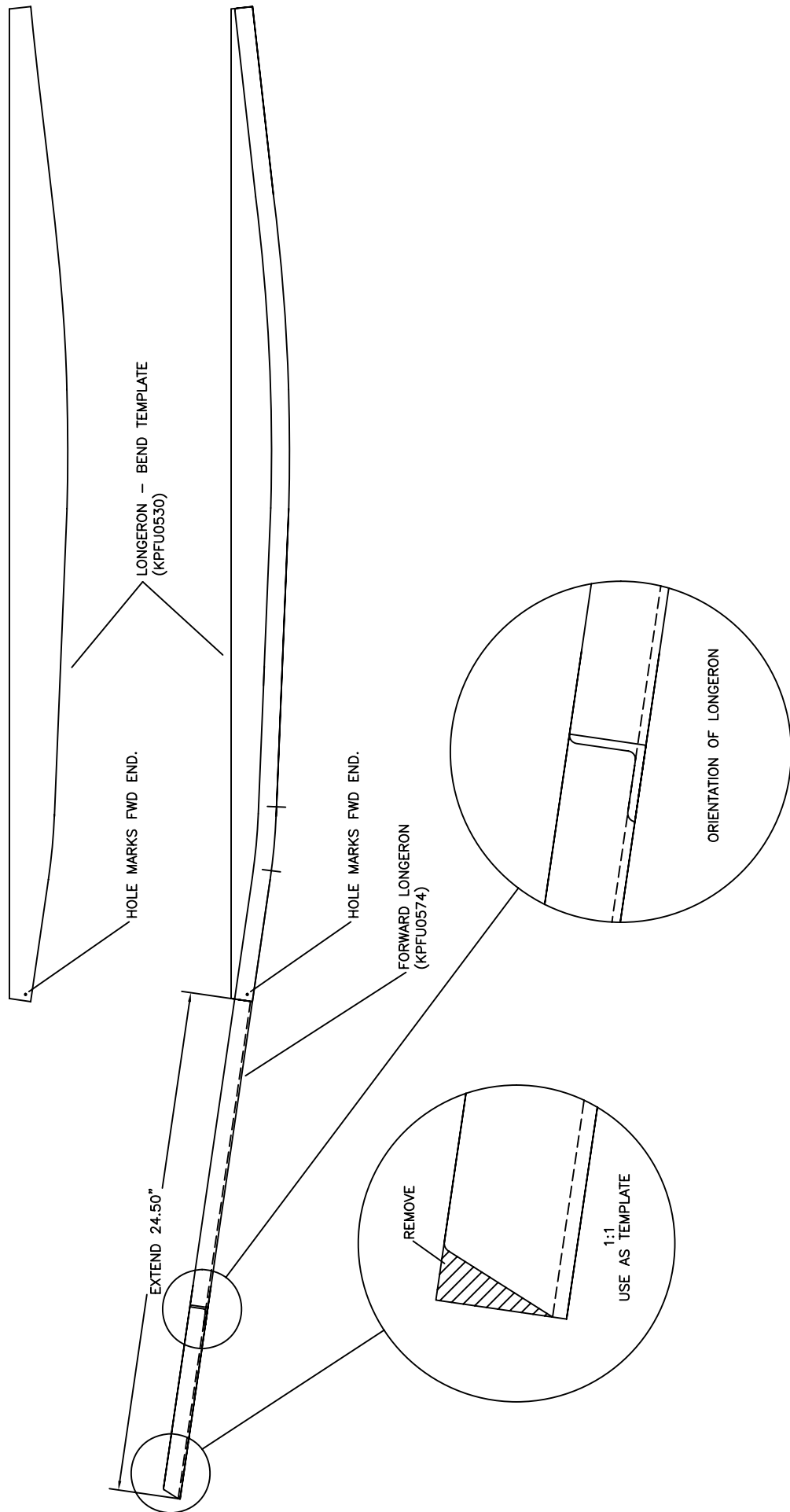

MD5046

**RRR** S-19 VENTERRA  
**FORWARD LONGERON MODIFICATION**  
**FIGURE 05B-08A**

FABRICATE 4 SHIMS FROM  
0.032" RAW STOCK

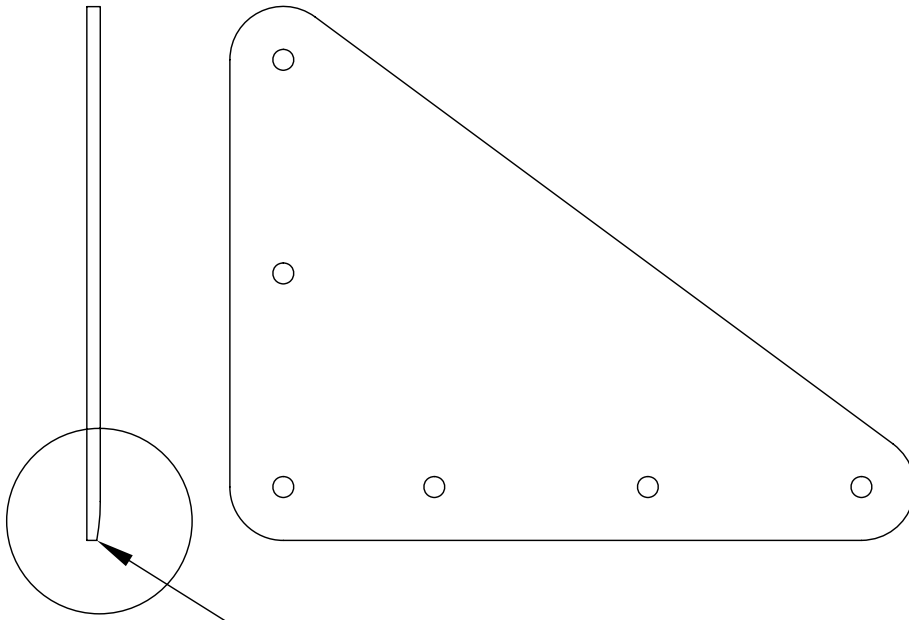

RADIUS CORNER  
TO FIT ANGLE

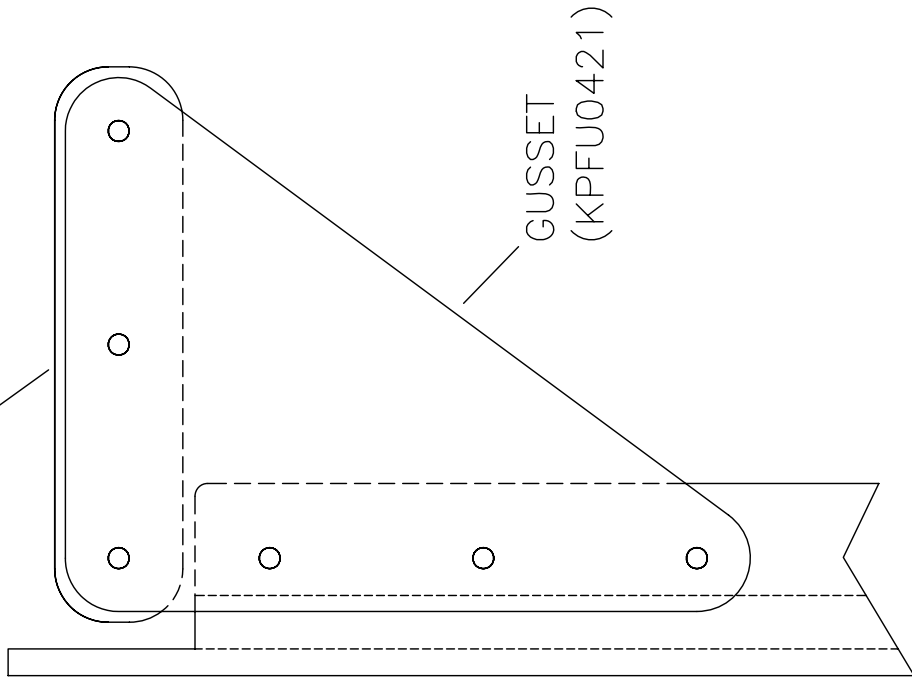

GUSSET  
(KPFU0421)

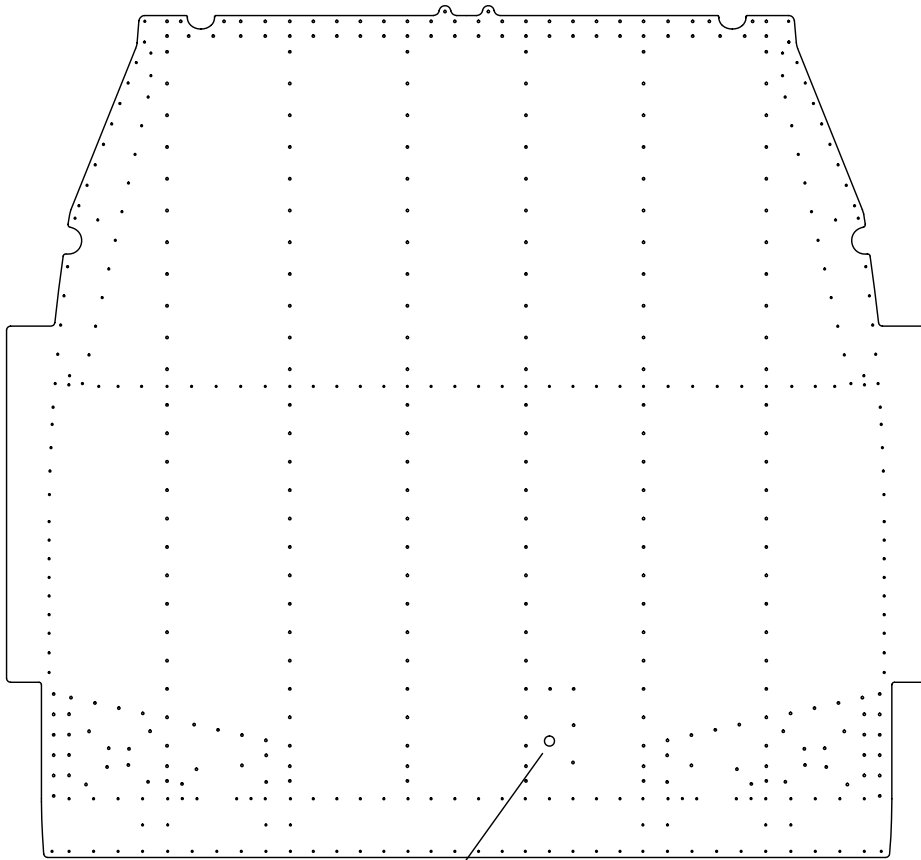

DENOTES RIGHT HAND  
SIDE OF SKIN

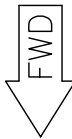

AS VIEWED FROM BELOW

MD5524

**RRR** S-19 VENTERRA  
**BELLY SKIN - CABIN MIDDLE ORIENTATION**  
**FIGURE 05B-13**

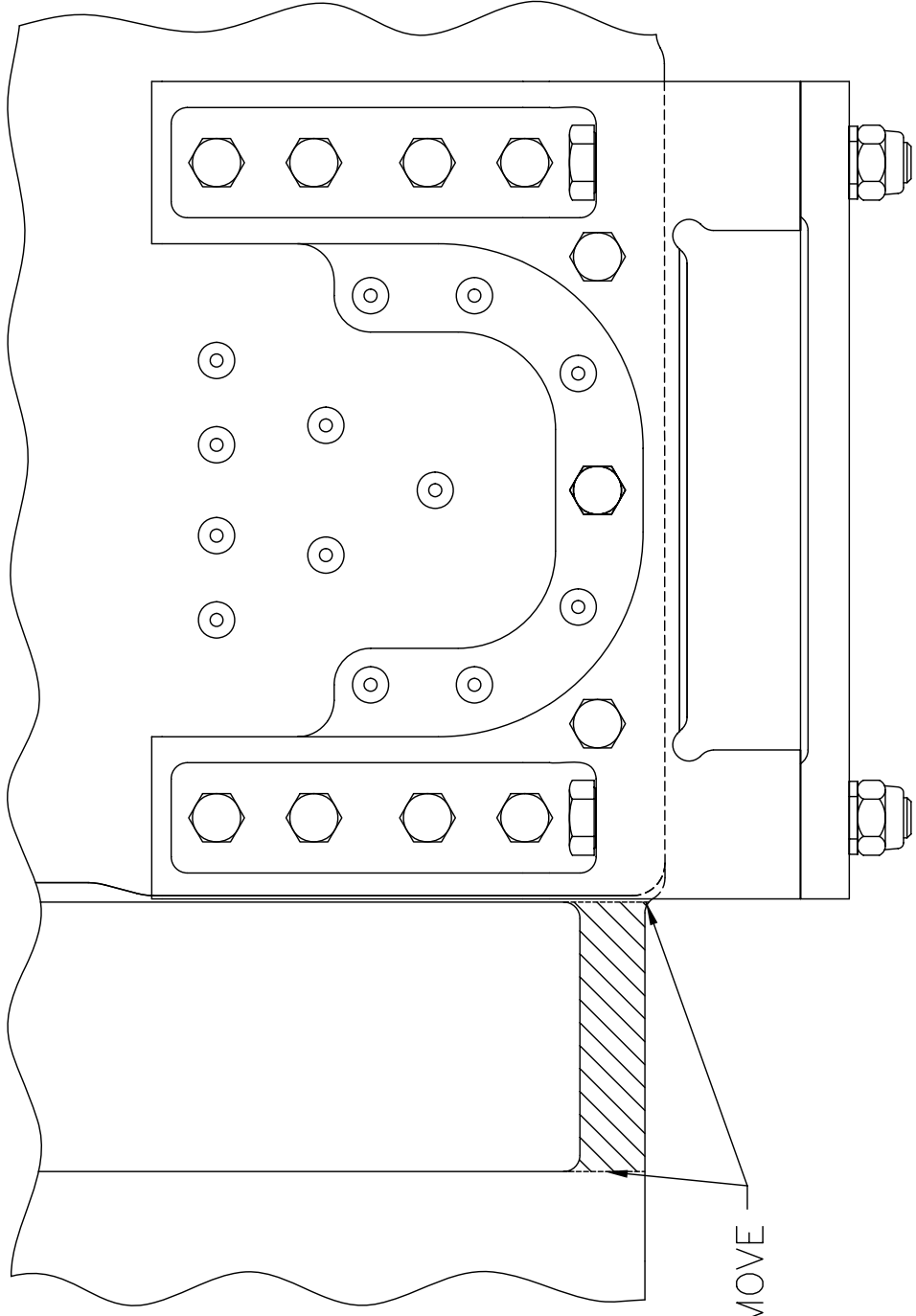

CUT AND REMOVE

MD4834

**RAMBO S-19 VENTERRA**  
**SIDE SKIN MODIFICATION**  
**FIGURE 05C-04**

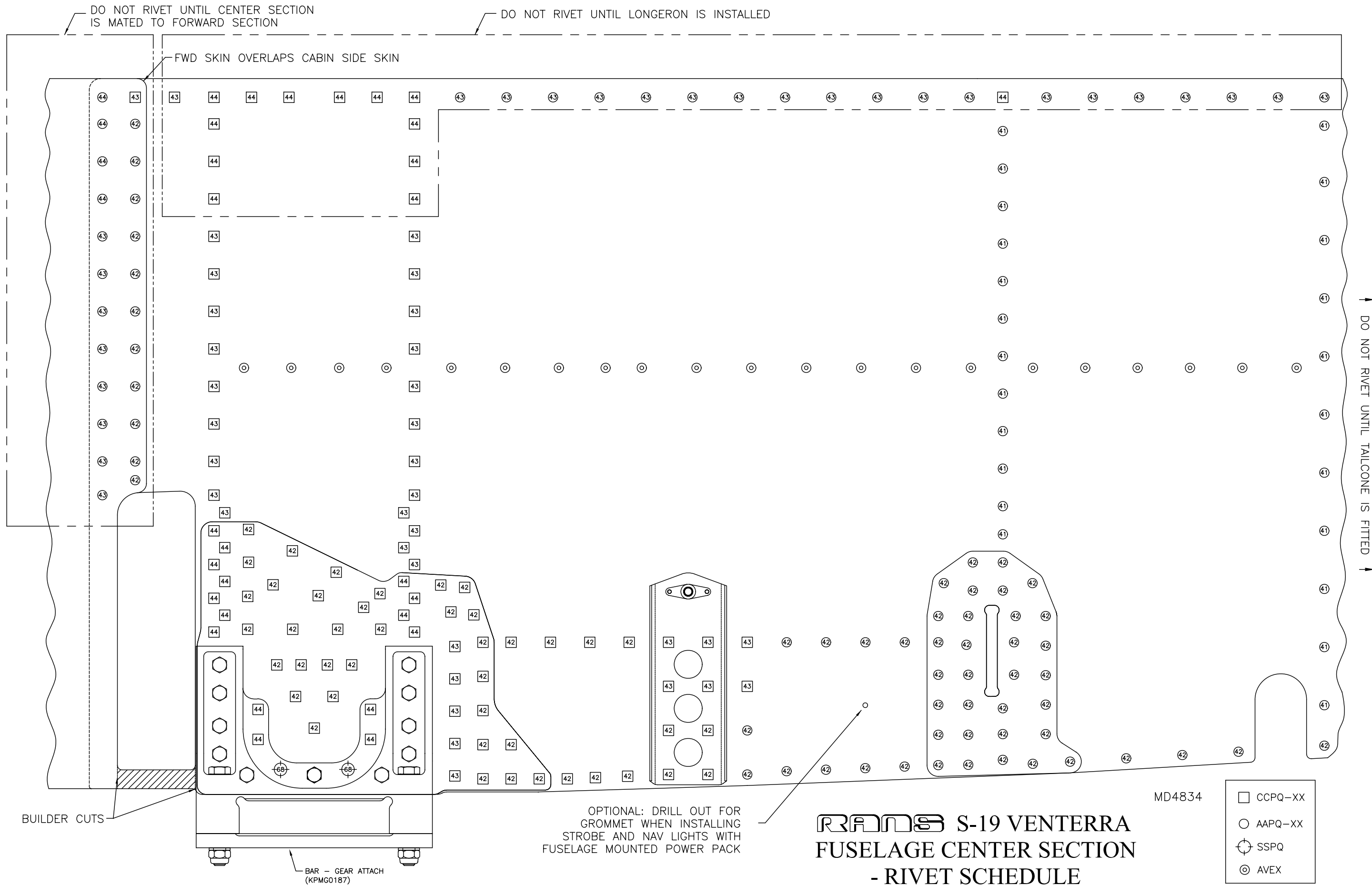

**RANS S-19 VENTERRA**  
**FUSELAGE CENTER SECTION**  
**- RIVET SCHEDULE**  
**FIGURE 05C-06**

MD4834

- CCPQ-XX
- AAPQ-XX
- ⊕ SSPQ
- ⊙ AVEX

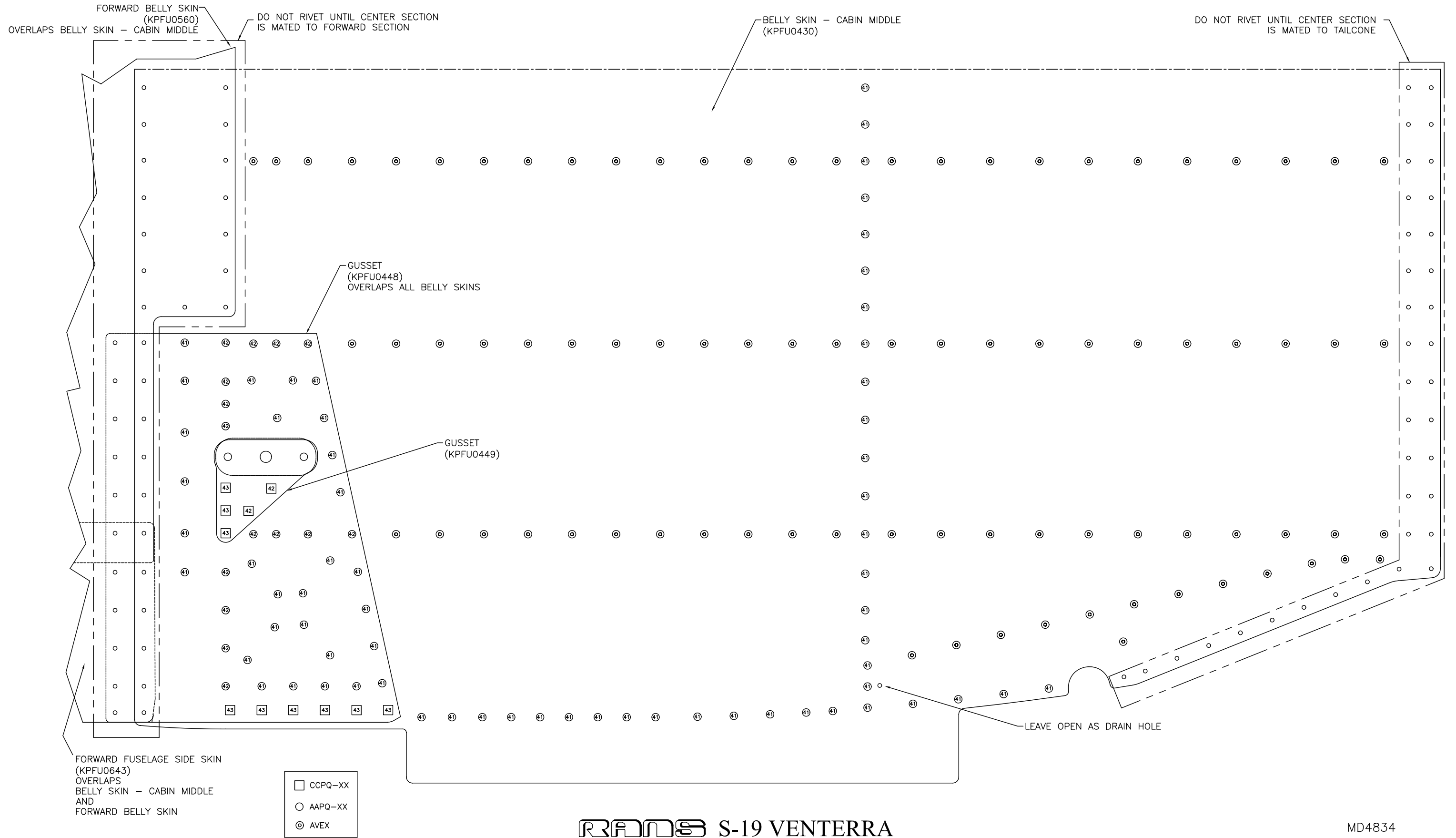

**RAMS S-19 VENTERRA**  
**FUSELAGE CENTER SECTION - RIVET SCHEDULE**  
**FIGURE 05C-06A**

MD4834

04/01/2011



## 06 – FUSELAGE – FORWARD SECTION

FIREWALL ASSEMBLY .....	06A-02
FIREWALL RIVET SCHEDULE .....	06A-04
FIREWALL ANGLE / FLOORBOARD CHANNEL DRILLING .....	06B-05
RUDDER PEDAL ATTACH NUT PLATE .....	06C-02
DUMMY BRAKE CYLINDERS .....	06D-05
STANDARD SINGLE BRAKE SYSTEM SCHEMATIC .....	06D-06
OPTIONAL DUAL BRAKE SYSTEM SCHEMATIC .....	06D-06A
STANDARD SINGLE BRAKE SYSTEM SCHEMATIC W/ OPTIONAL PARK BRAKE ....	06D-06B
OPTIONAL DUAL BRAKE SYSTEM SCHEMATIC W/ OPTIONAL PARK BRAKE.....	06D-06C
BRAKE LINE ROUTING .....	06D-07
BRAKE LINE LOCATION.....	06D-07A
FIREWALL - OPTIONAL PARKING BRAKE .....	06D-08
CABLE KEEPER MODIFICATION.....	06D-09
FWD FUSELAGE – ACCESS OPENING .....	06G-00
FWD FUSELAGE SIDE SKIN BENDING.....	06G-01
FWD FUSELAGE SIDE SKIN BENDING.....	06G-01A
FWD FUSELAGE SIDE SKIN BENDING.....	06G-01B
FWD FUSELAGE SIDE SKIN BENDING.....	06G-01C
FWD FUSELAGE – TOP SKIN – RIVET SCHEDULE .....	06G-05
FWD FUSELAGE – BELLY SKIN - RIVET SCHEDULE .....	06G-05A
FWD FUSELAGE – SIDE SKIN – RIVET SCHEDULE .....	06G-05B
ROLL BAR BRACE INSTALLATION .....	06H-05

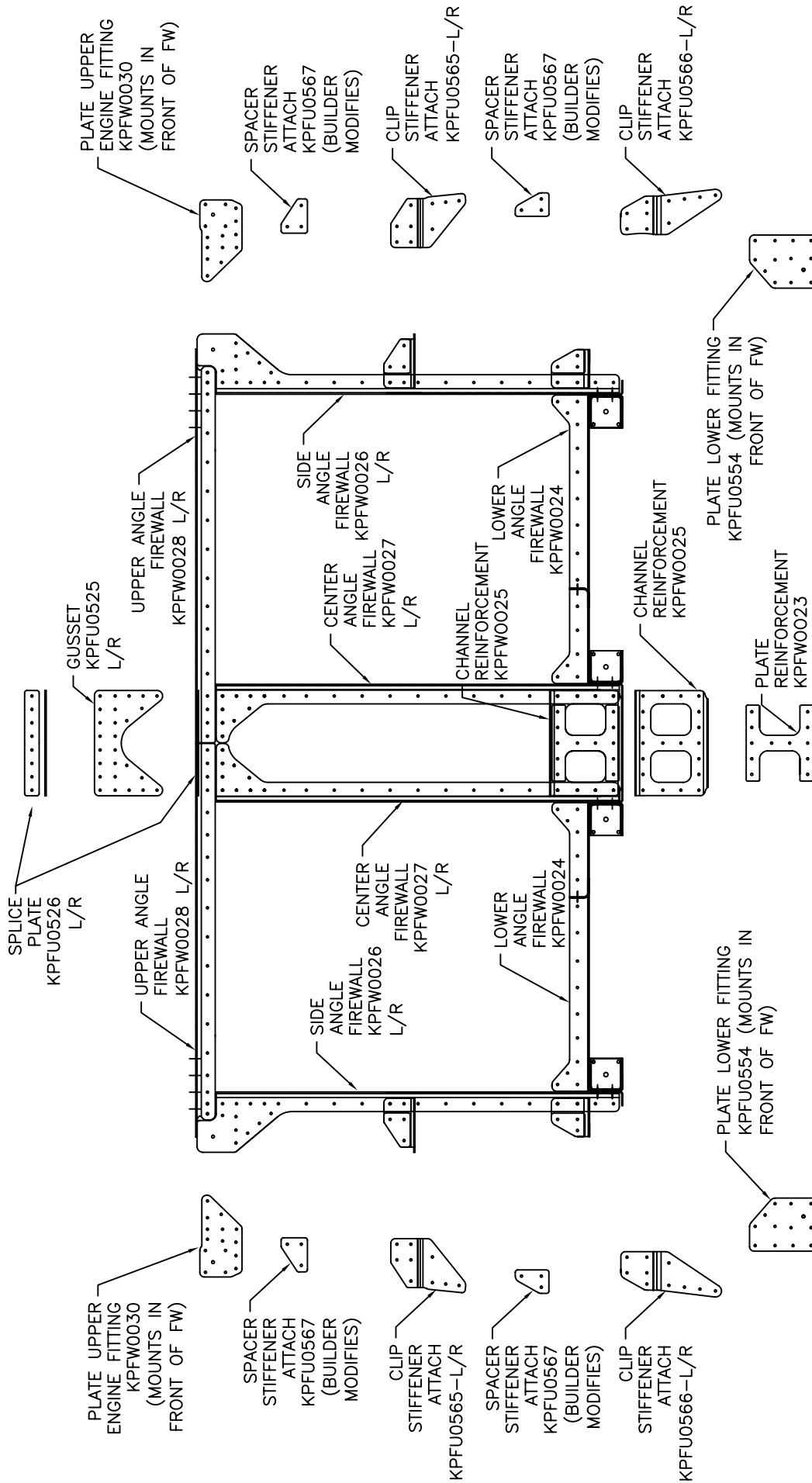

MD5044

**RRR** S-19 VENTERRA  
 FIREWALL ASSEMBLY  
 FIGURE 06A-02

ALL RIVETS ARE CCPQ-XX  
FIREWALL RIVETING IS SYMMETRICAL (RH SHOWN)

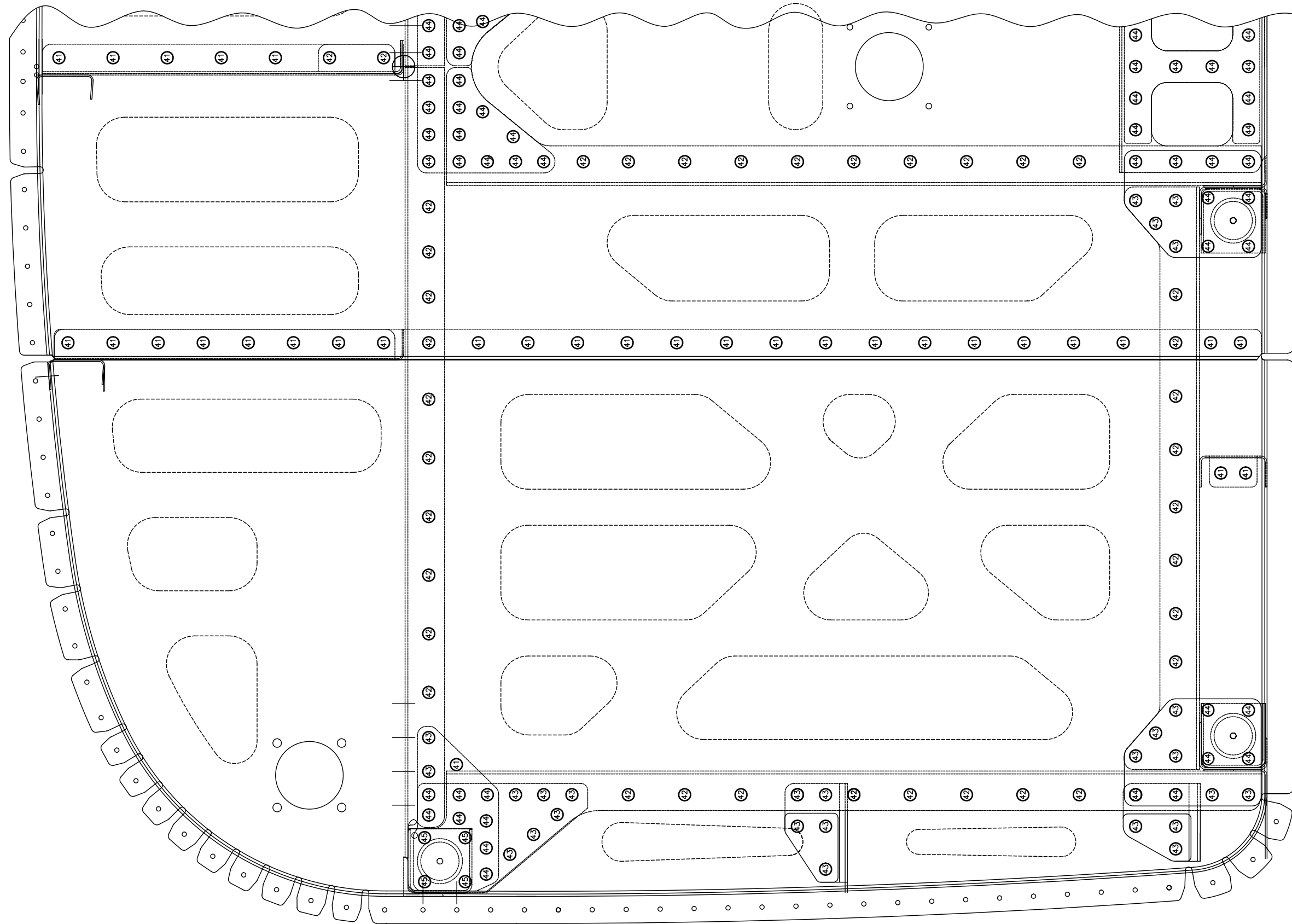

MD5045

**RAMS S-19 VENTERRA**  
**FIREWALL RIVET SCHEDULE**  
**FIGURE 06A-04**

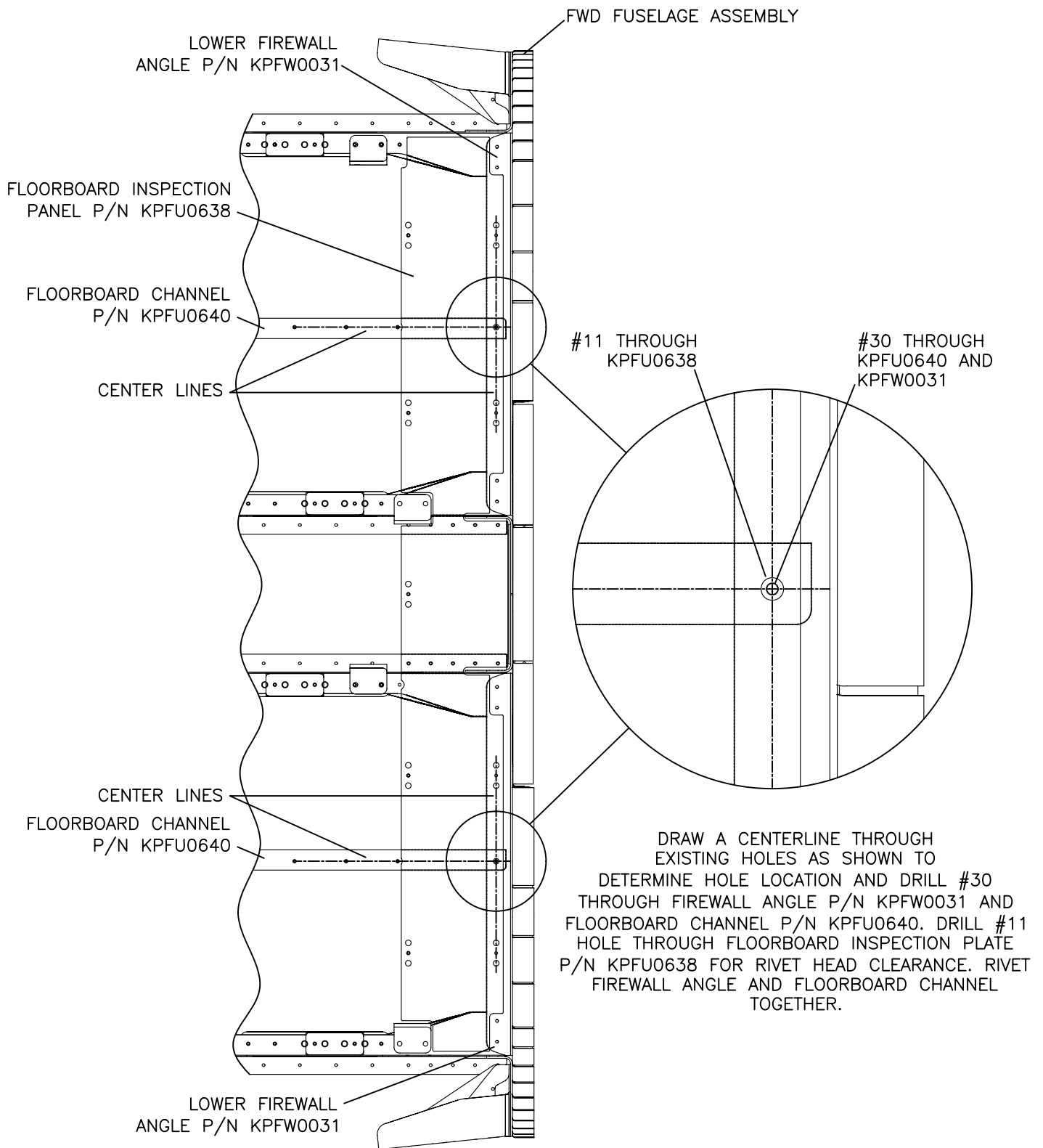

MD5233

**RANS S-19 VENTERRA**  
**FIREWALL ANGLE / FLOORBOARD CHANNEL DRILLING**

**FIGURE 06B-05**

04/01/2011

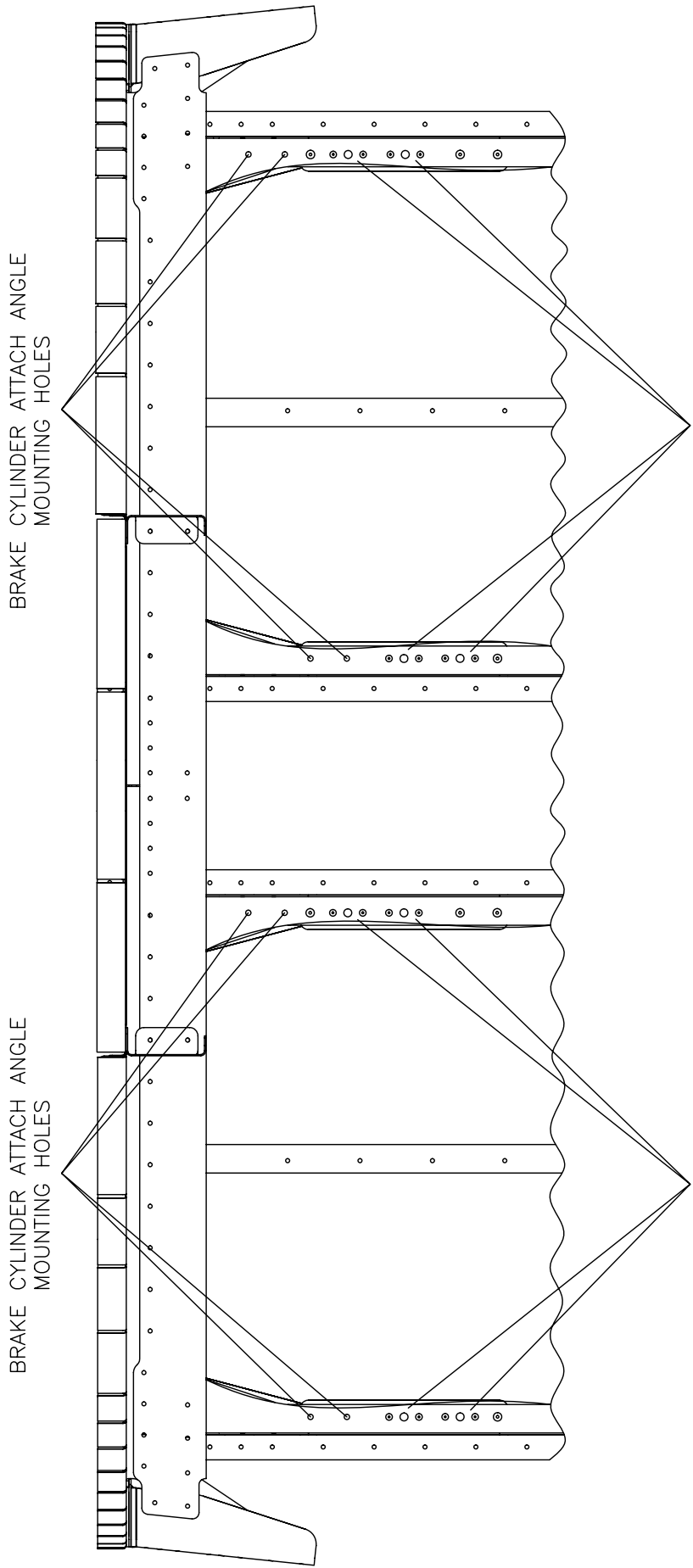

BRAKE CYLINDER ATTACH ANGLE  
MOUNTING HOLES

BRAKE CYLINDER ATTACH ANGLE  
MOUNTING HOLES

NOTE STAGGERED POSITION OF NUT PLATES

NOTE STAGGERED POSITION OF NUT PLATES

MD5060

**RAMS** S-19 VENTERRA  
**RUDDER PEDAL ATTACH NUT PLATE**  
**FIGURE 06C-02**

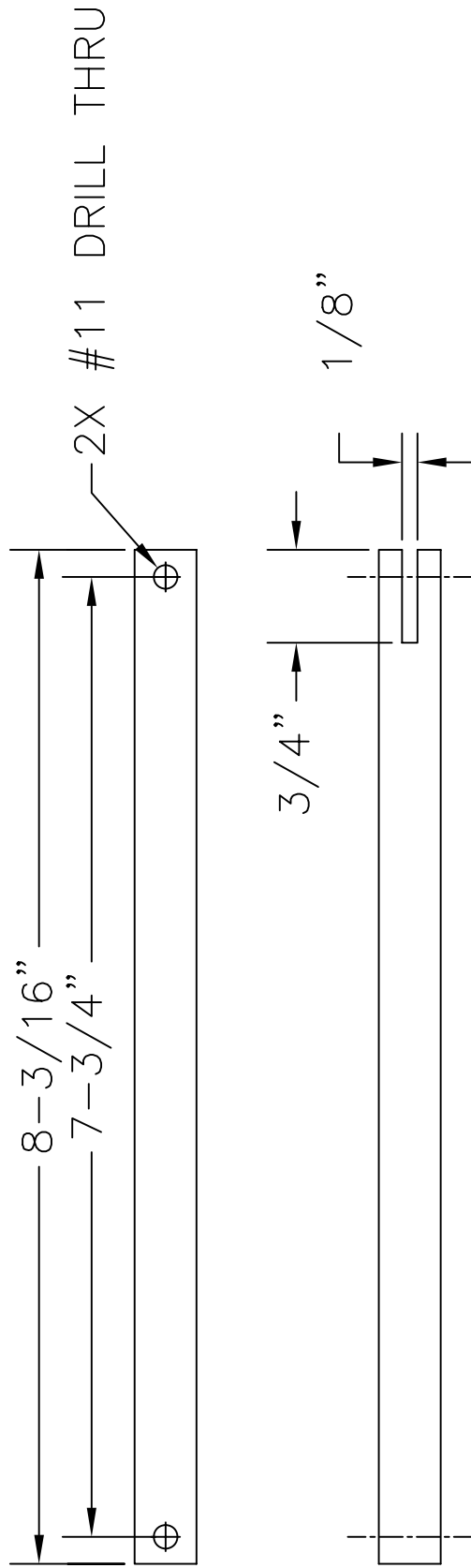

FABRICATE 2 FROM RAW STOCK

MD5211

**RAMBO** S-19 VENTERRA  
 DUMMY BRAKE CYLINDER  
 FIGURE 06D-05

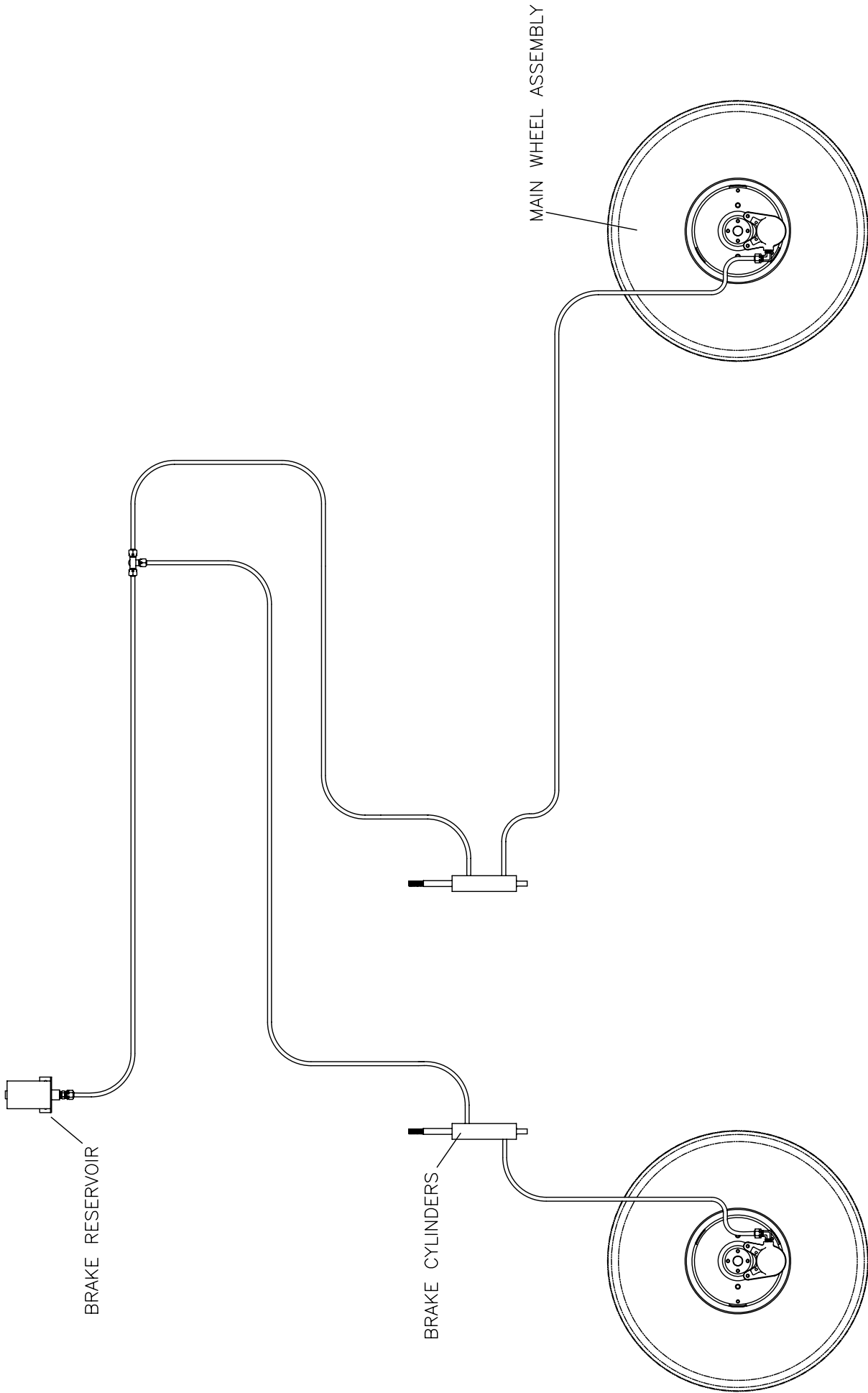

MD5079

**RAMSES S-19 VENTERRA**  
**STANDARD SINGLE BRAKE SYSTEM SCHEMATIC**  
**FIGURE 06D-06**

04/01/2011

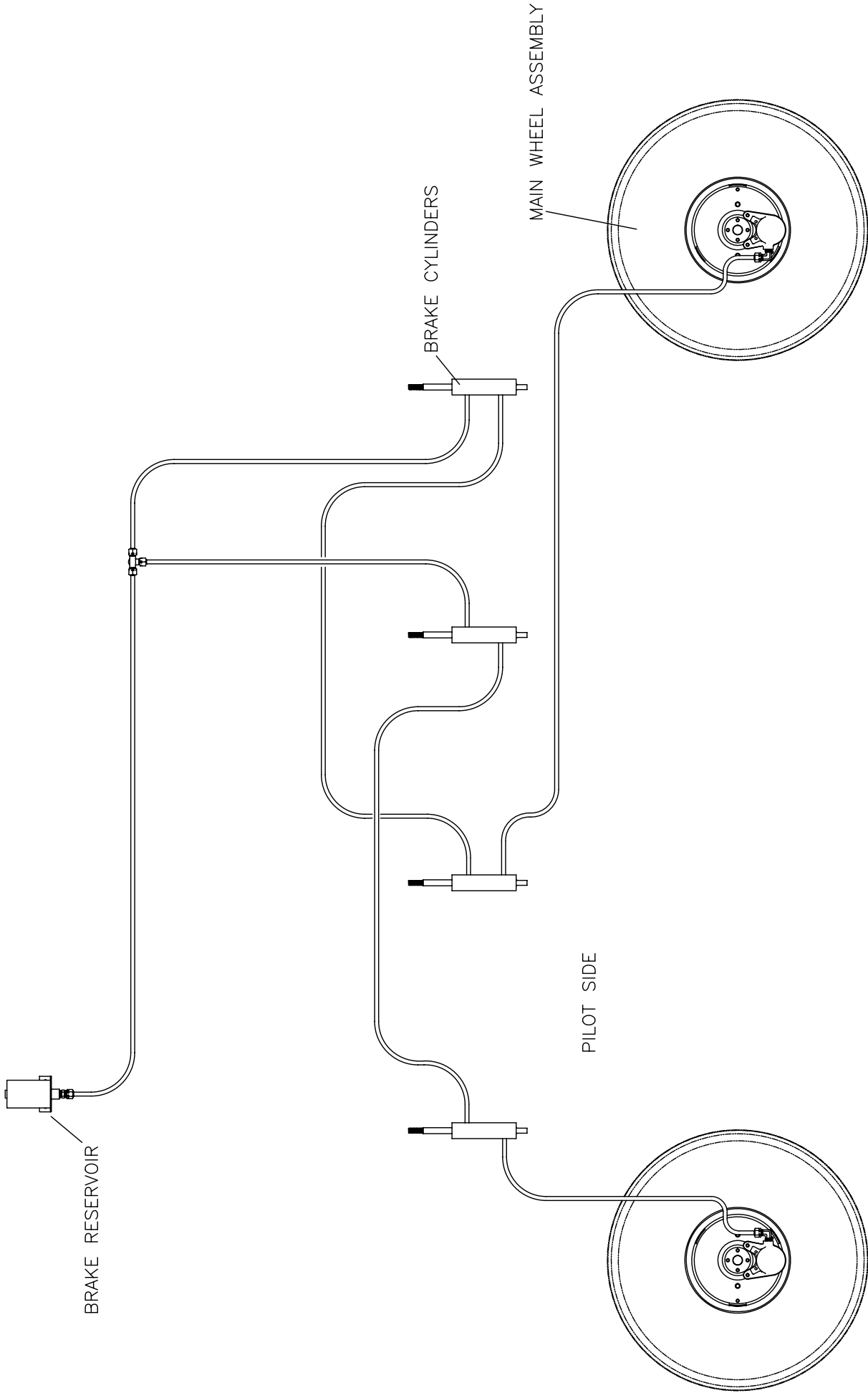

MD5079

**RAMCO S-19 VENTERRA**  
**OPTIONAL DUAL BRAKE SYSTEM SCHEMATIC**  
**FIGURE 06D-06A**



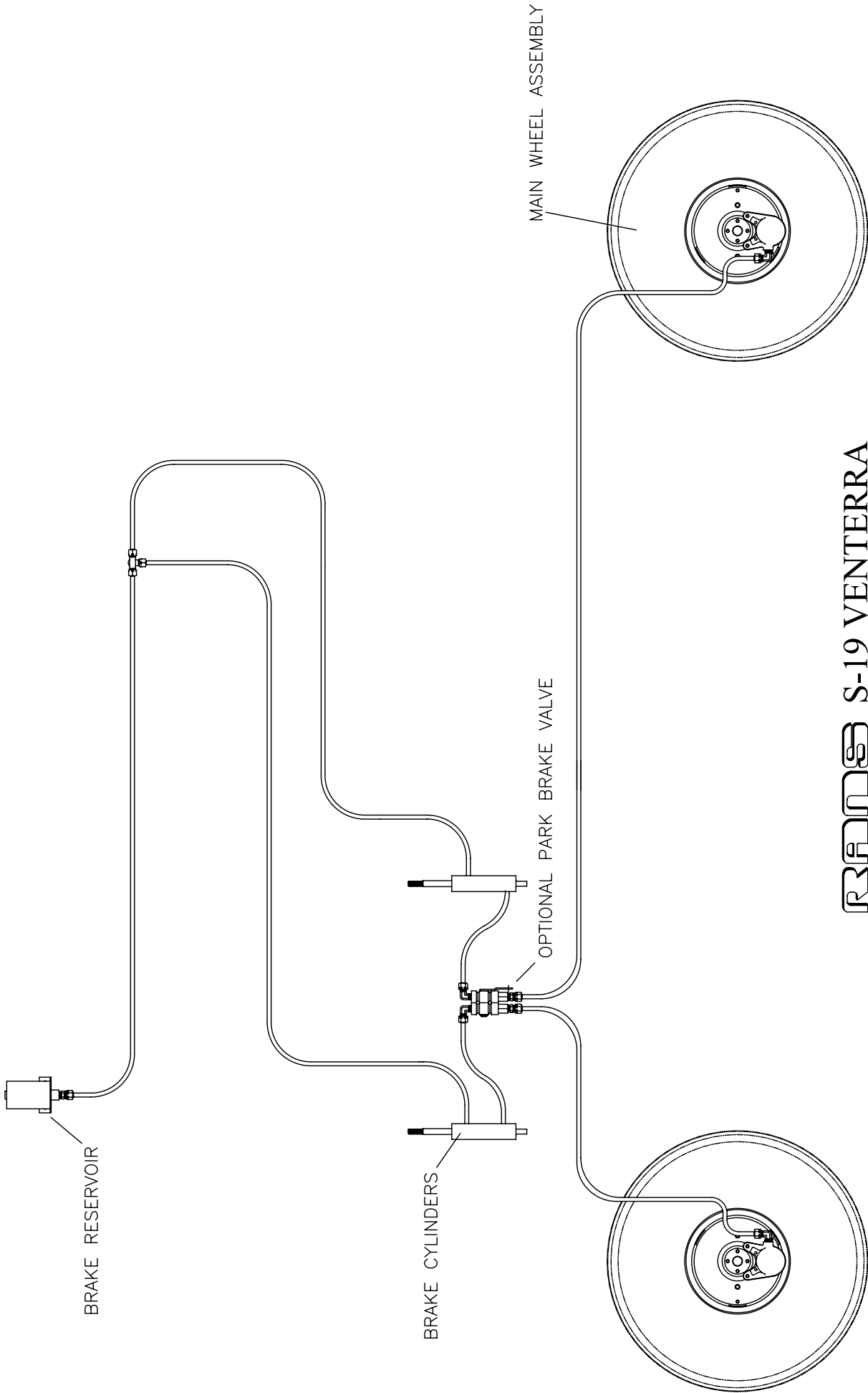

**RAMS S-19 VENTERRA**  
**STANDARD SINGLE BRAKE SYSTEM SCHEMATIC**  
**WITH OPTIONAL PARKING BRAKE**  
**FIGURE 06D-06B**

MD5079

04/01/2011

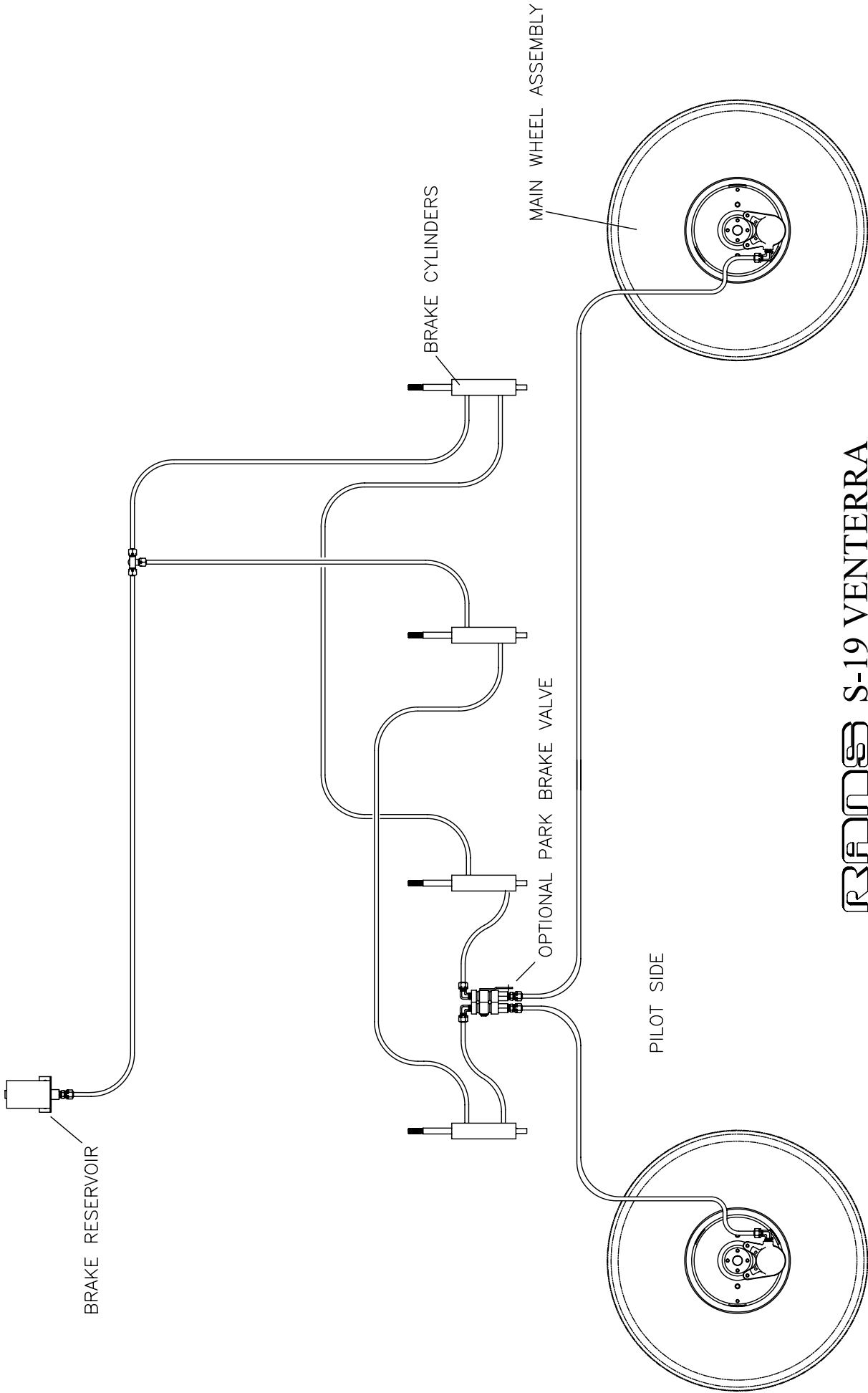

MD5079

**RAMS S-19 VENTERRA**  
**OPTIONAL DUAL BRAKE SYSTEM SCHEMATIC**  
**WITH OPTIONAL PARKING BRAKE**  
**FIGURE 06D-06C**

DRILL TOOLING HOLE TO 7/16"  
INSTALL GROMMET  
ROUTE BRAKE LINE

LEFT HAND SIDE SHOWN

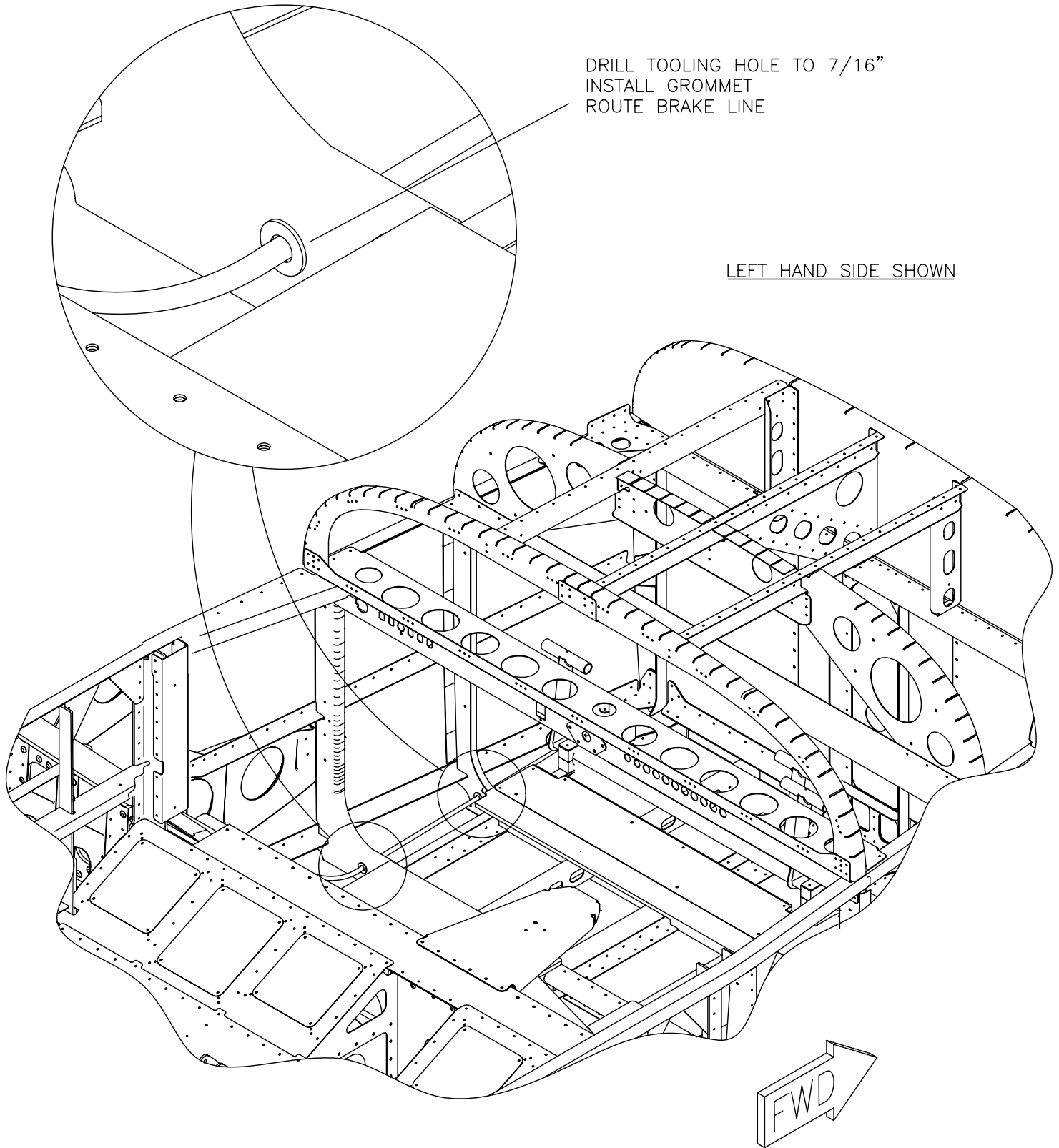

MD5467

**RANS S-19 VENTERRA**  
**BRAKE LINE ROUTING**  
**FIGURE 06D-07**

04/01/2011

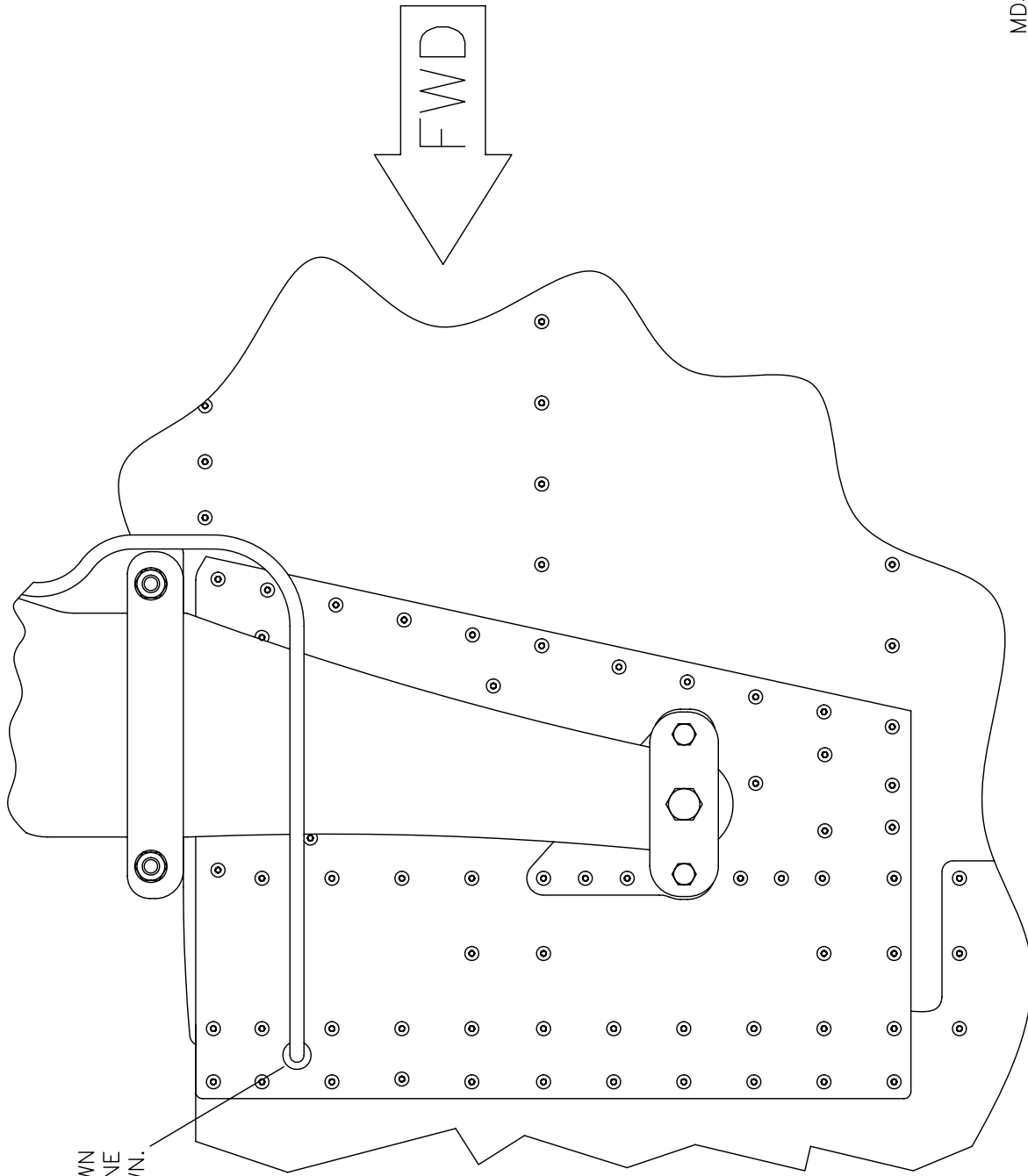

MD5467

**RAM S-19 VENTERRA**  
**BRAKE LINE LOCATION**  
**FIGURE 06D-07A**

HYDRAULIC BRAKE RESERVOIR  
KSBS0034

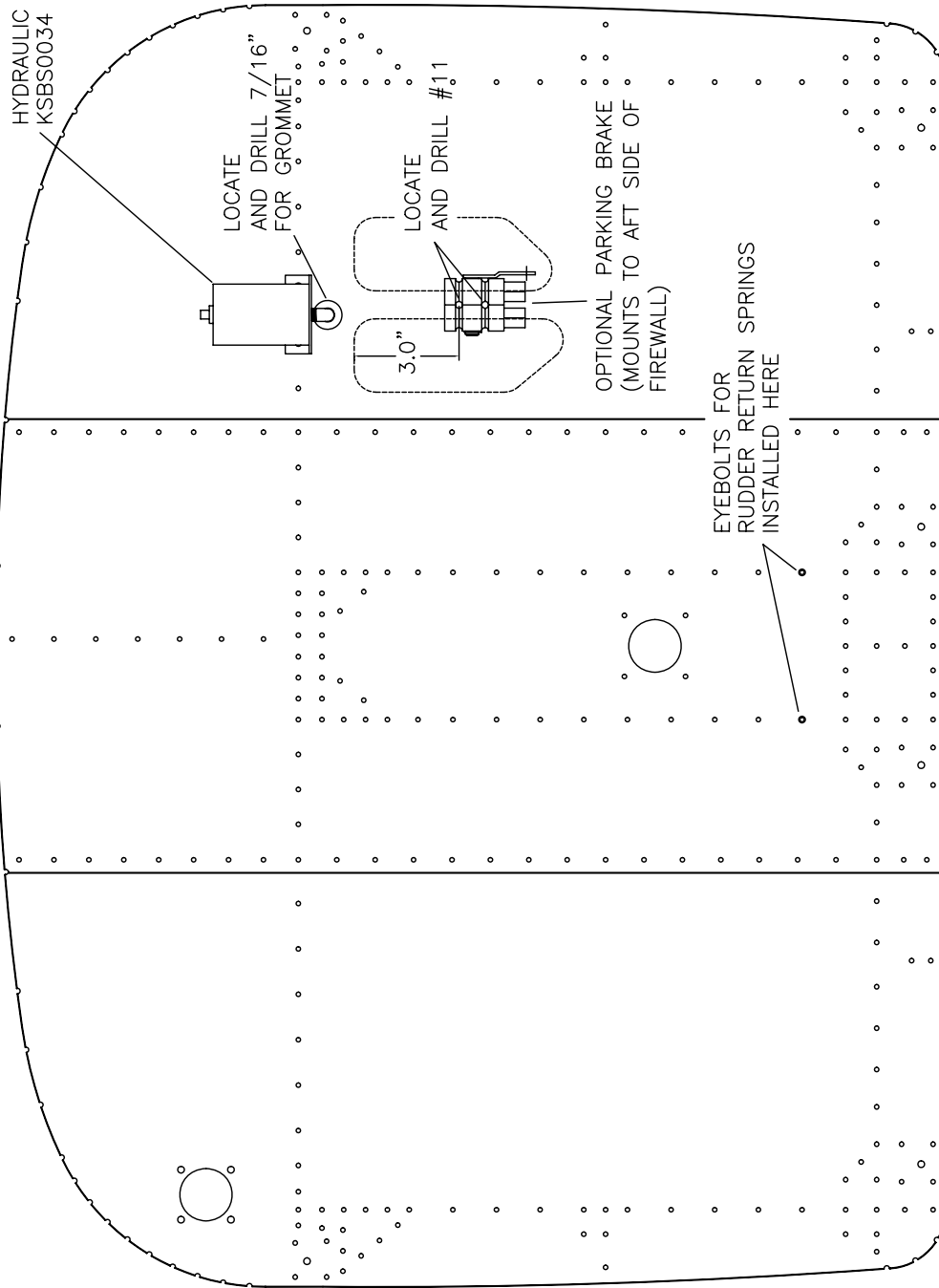

**RAMS** S-19 VENTERRA

**FIREWALL  
OPTIONAL PARKING BRAKE  
FIGURE 06D-08**

MD5230

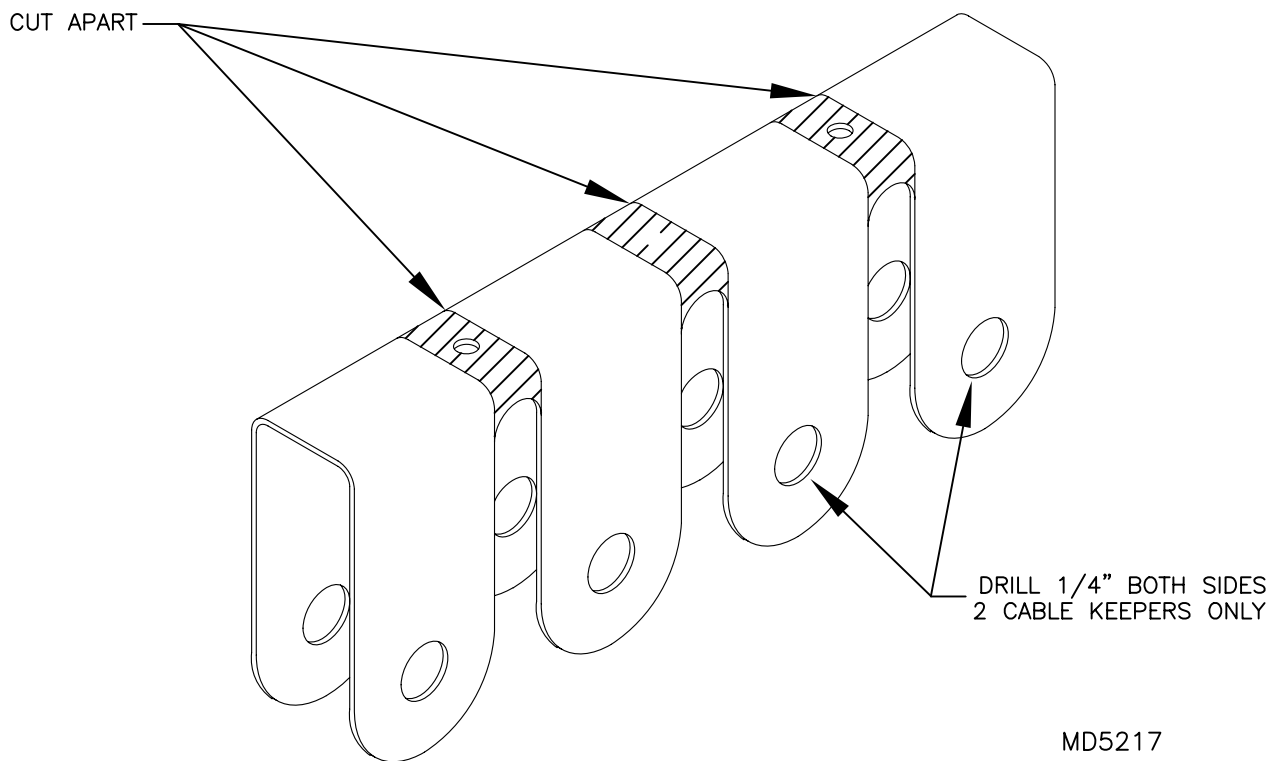

MD5217

**RANS S-19 VENTERRA**  
**CABLE KEEPER MODIFICATION**  
**FIGURE 06D-09**

04/01/2011

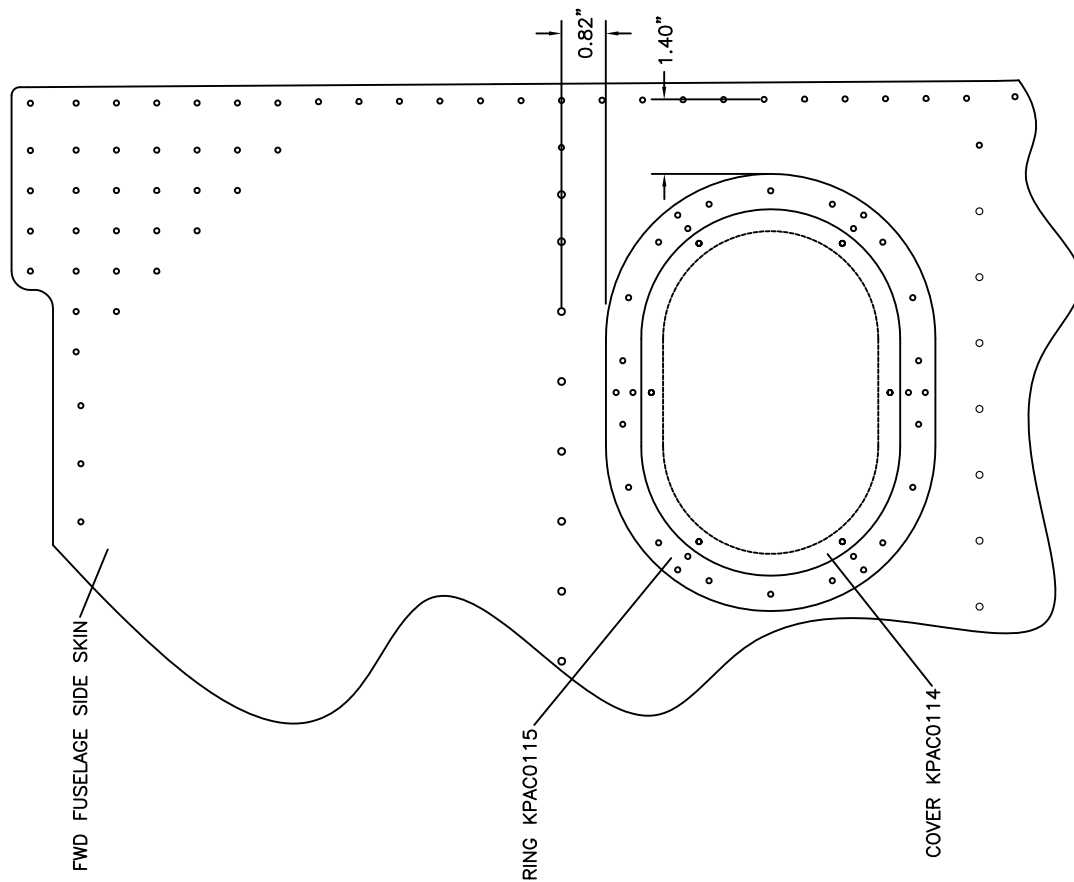

PARTS REQUIRED PER SIDE:

ACCESS PANEL RING	KPAC0115	1
ACCESS PANEL	KPAC0114	1
1/8" ALUMINUM RIVET	AAPQ-41	18
#8 SINGLE-EAR NUT PLATE	MS21051-08	6
3/32" ALUMINUM RIVET	40APR1/8	12
#8 TRUSSHEAD SCREW	AN526-832R6	6

FLUSH RIVETS MAY ALSO BE USED

1. PLACE RING (KPAC0115) AS SHOWN AND TRANSFER DRILL HOLES INTO FWD FUSELAGE SIDE SKIN. REMOVE RING.
2. CLECO PANEL TO INNER HOLES AND USE AS TEMPLATE FOR LARGE CUT OUT.
3. RIVET RING AND NUT PLATES TO SIDE SKIN.

ACCESS PANELS MAY BE ADDED TO EACH SIDE OF FUSELAGE IF DESIRED.  
PARTS LISTED ABOVE MAY BE ORDERED FROM RANS PARTS DEPARTMENT.

MD5236

**RANS S-19 VENTERRA**  
**OPTION: FWD FUSELAGE SKIN - ACCESS PANEL**  
**FIGURE 06G-00**

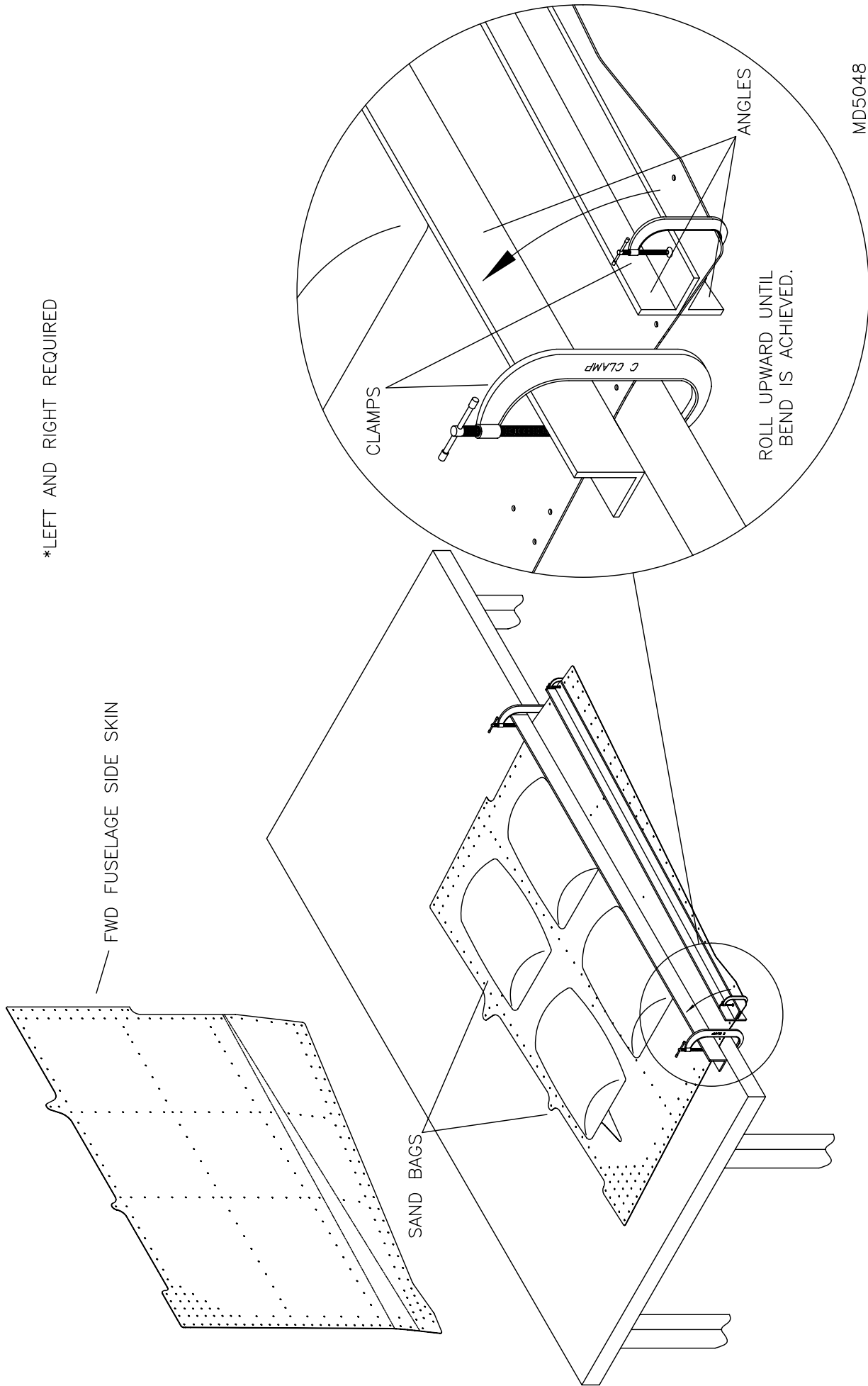

\*LEFT AND RIGHT REQUIRED

MD5048

**RRR** S-19 VENTERRA  
 FWD FUSELAGE SIDE SKIN BENDING  
 FIGURE 06G-01



SEE FIGURE 06G-01B FOR 1:1

SEE FIGURE 06G-01C FOR 1:1

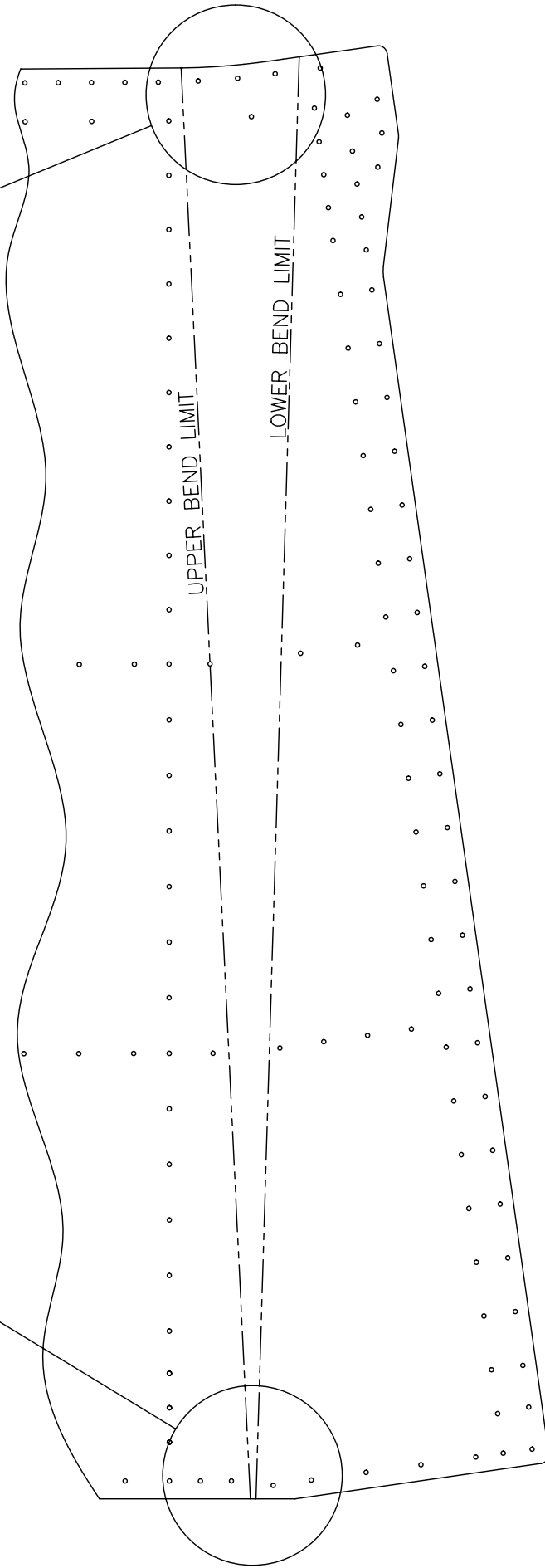

MD5048

**RAMS S-19 VENTERRA**  
**FWD FUSELAGE SIDE SKIN BENDING**  
**FIGURE 06G-01A**



**RANS S-19 VENTERRA**  
**FWD FUSELAGE SIDE SKIN BENDING**  
**FIGURE 06G-01B**

MD5048

04/01/2011

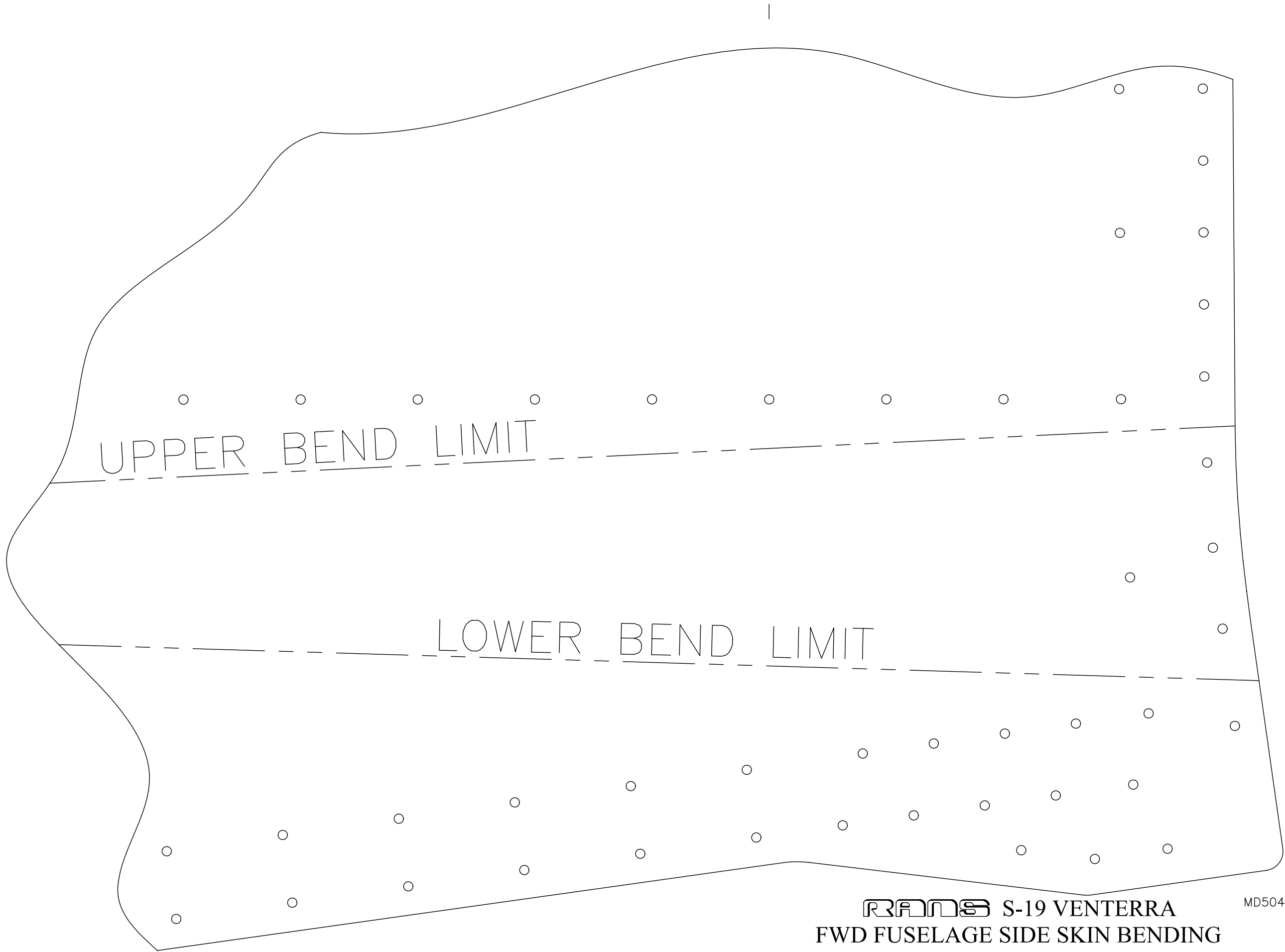

UPPER BEND LIMIT

LOWER BEND LIMIT

**RAMS S-19 VENTERRA**  
**FWD FUSELAGE SIDE SKIN BENDING**  
**FIGURE 06G-01C**

MD5048

FWD FUSELAGE SIDE SKIN  
(KPFU0643)

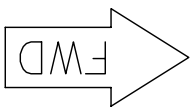

DECK SKIN  
(KPFU0644)  
LH SIDE SHOWN AS VIEWED FROM TOP

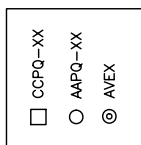

COWLING ATTACH STRAP - SIDE  
(KPFU0541)

COWLING ATTACH STRAP (TOP)  
(KPFU0537)

MD5090

**RAMS S-19 VENTERRA**  
**FWD FUSELAGE - TOP SKIN - RIVET SCHEDULE**  
**FIGURE 06G-05**

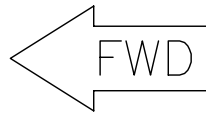

COWLING ATTACH STRAP - SIDE  
(KPFU0541)

COWLING ATTACH STRAP - BOTTOM  
(KPFU0585)

FWD FUSELAGE SIDE SKIN  
(KPFU0643)

REFER TO TAILCONE TO CENTER  
SECTION RIVET SCHEDULE.  
DO NOT RIVET UNTIL THE 2  
SECTIONS ARE JOINED.

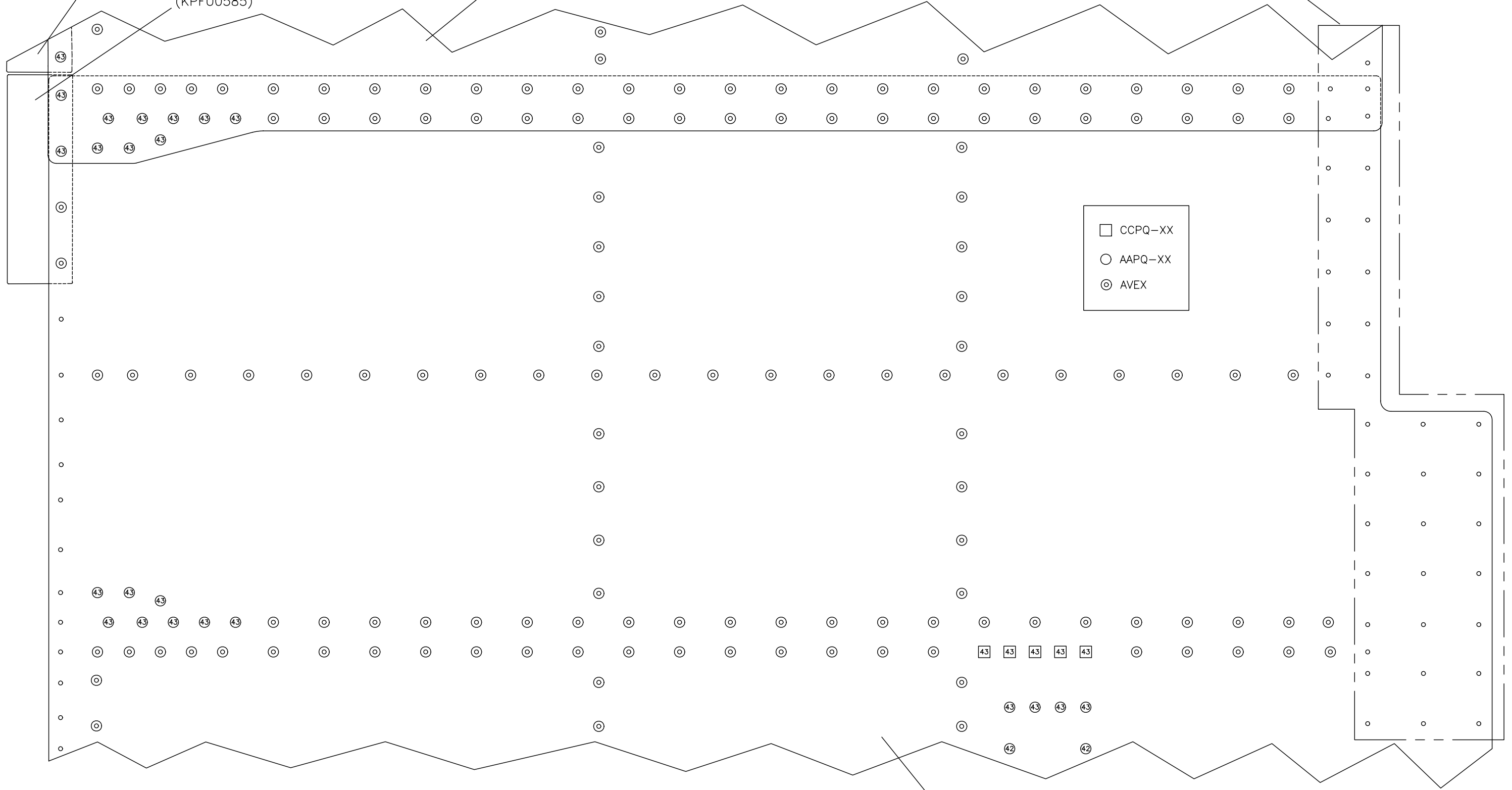

□	CCPQ-XX
○	AAPQ-XX
⊙	AVEX

**RANS S-19 VENTERRA**  
**FWD FUSELAGE - BELLY SKIN - RIVET SCHEDULE**  
**FIGURE 06G-05A**

FWD BELLY SKIN  
(KPFU0560)  
LH SIDE SHOWN, AS VIEWED FROM BOTTOM

MD5089

04/01/2011

FWD

COWLING ATTACH STRAP - SIDE  
(KPFU0541)

UPPER DECK SKIN OVERLAPS FUSELAGE SIDE SKIN

DECK SKIN  
(KPFU0644)

CABIN SIDE SKIN  
(KPFU0460)

COWLING ATTACH STRAP - BOTTOM  
(KPFU0585)

FWD BELLY SKIN  
(KPFU0560)

FWD FUSELAGE SIDE SKIN OVERLAPS CABIN  
SIDE SKIN AND FWD FUSELAGE BELLY SKIN

□	CCPQ-XX
○	AAPQ-XX
⊙	AVEX

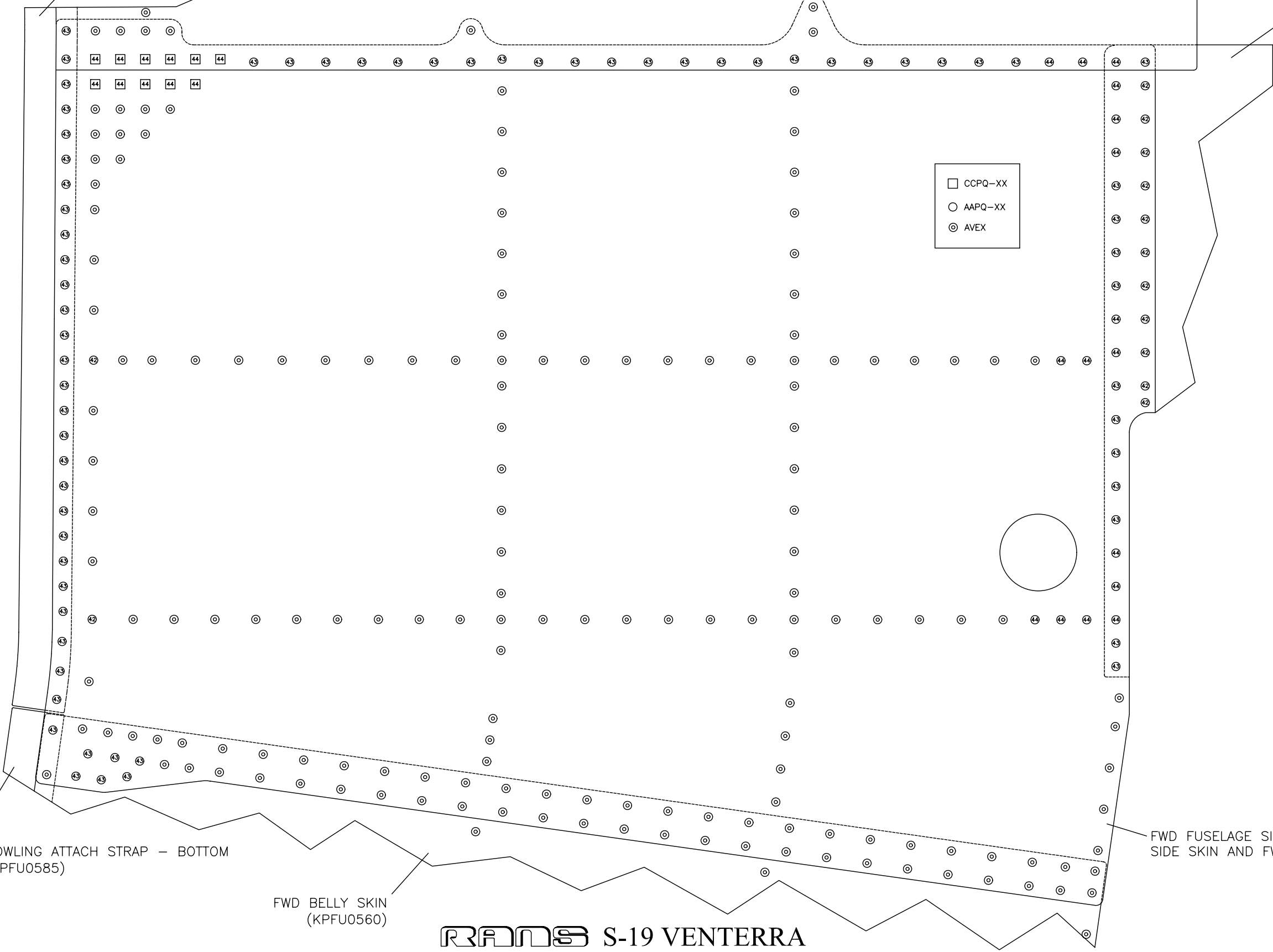

**RAMS S-19 VENTERRA**  
**FWD FUSELAGE - SIDE SKIN - RIVET SCHEDULE**  
**FIGURE 06G-05B**

MD5088

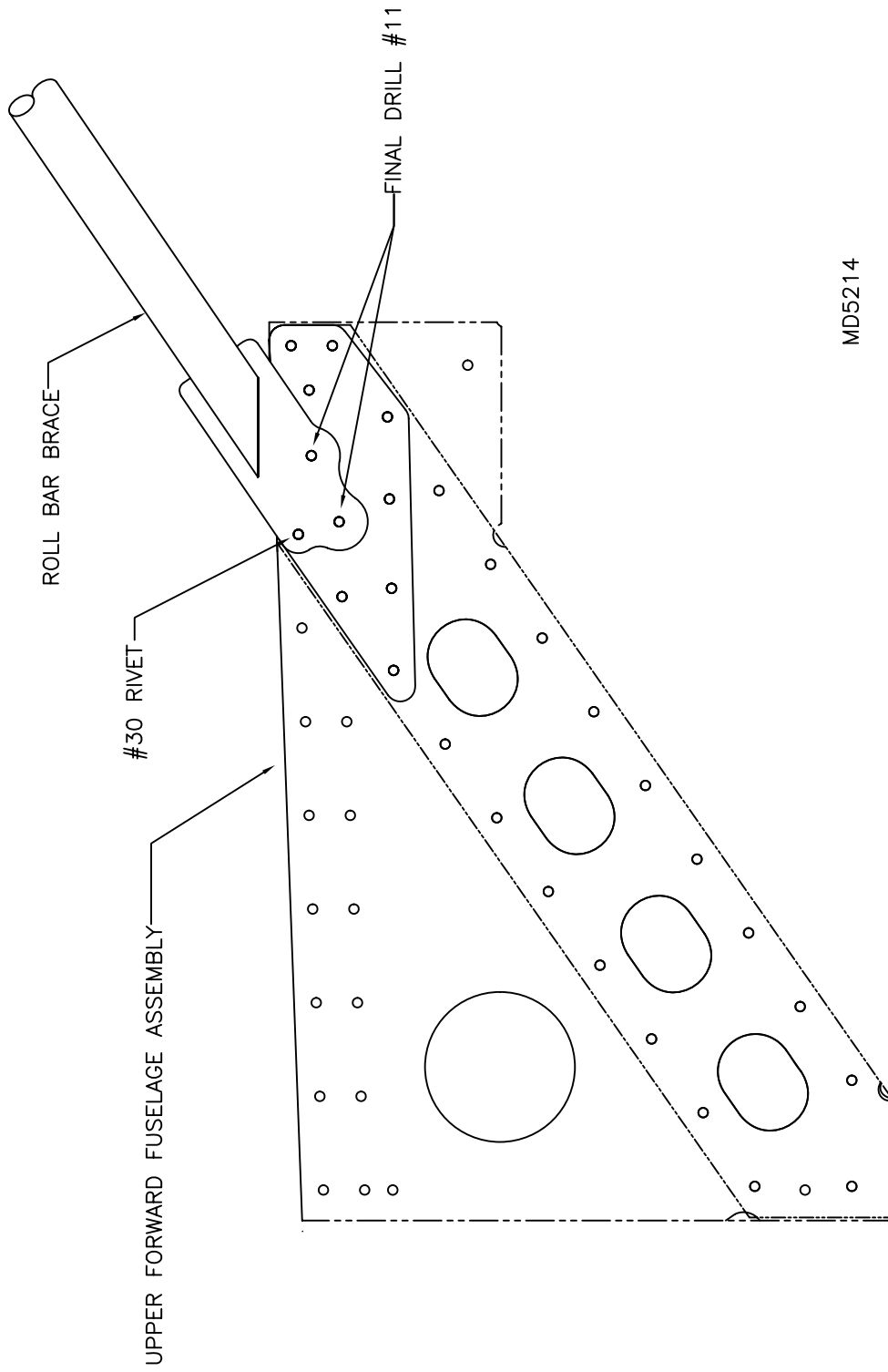

MD5214

**RRAD** S-19 VENTERRA  
 ROLL BAR BRACE INSTALLATION  
 FIGURE 06H-05

## 07 – FUSELAGE – TAILCONE

TAILCONE SKIN FORMING .....	07-03
FUSELAGE TAILCONE SIDE SKIN MODIFICATION .....	07-04
REAR BULKHEAD SIDE STIFFENER .....	07-06
TAILCONE BELLY SKIN ORIENTATION .....	07-09
BULKHEAD #5 RIVET SCHEDULE .....	07-13
AFT SIDE SKIN RIVET SCHEDULE .....	07-15
AFT BELLY SKIN RIVET SCHEDULE .....	07-15A
BELLCRANK ATTACH RIVET SCHEDULE .....	07A-02
INSPECTION PANEL INSTALLATION .....	07B-06
BULKHEAD #1 ASSEMBLY .....	07C-02
UPPER BULKHEAD #1 RIVET SCHEDULE .....	07C-02A
SIDEWALL STIFFENER MODIFICATION .....	07C-04
TAILCONE LONGERON .....	07D-02
TAILCONE LONGERON .....	07D-03
TAILCONE LONGERON .....	07D-04
BULKHEAD TOP #4 RIVET SCHEDULE .....	07F-01
VERTICAL STABILIZER ALIGNMENT .....	07F-06
SEAT BELT GUSSET .....	07G-06
FWD FUSELAGE TO CENTER SECTION RIVET SCHEDULE .....	07H-09
TAILCONE TO CENTER SECTION RIVET SCHEDULE .....	07H-09A
TAILCONE TO CENTER SECTION RIVET SCHEDULE .....	07H-09B
LOWER TAILCONE STINGER TRIMMING .....	07I-02
TAILCONE STINGER .....	07I-03
TAILCONE STINGER CUT-OUT .....	07I-05



STINGER ATTACH.....07I-06

TAILCONE STINGER BULKHEAD TRIMMING.....07I-09

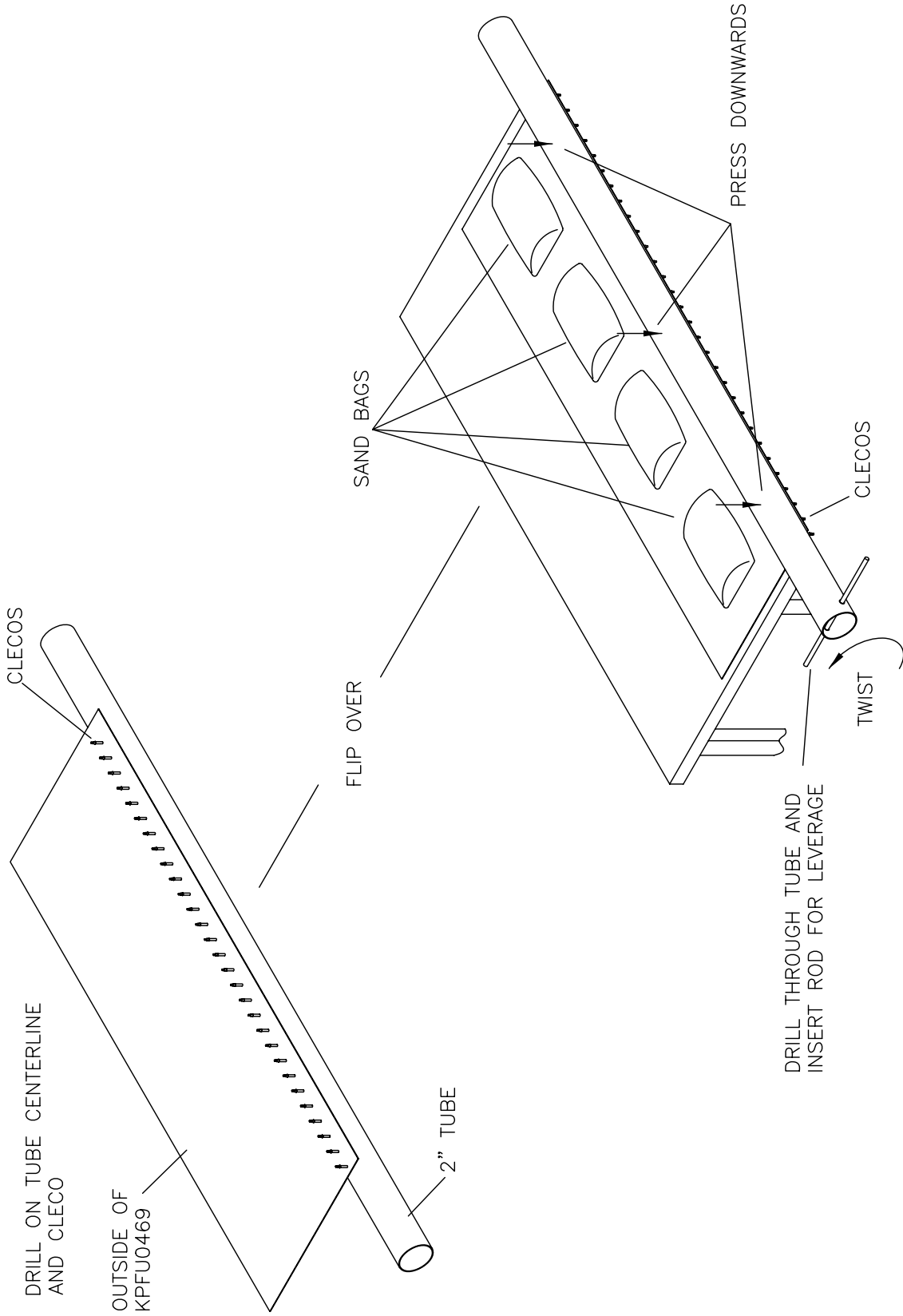

**RRMO S-19 VENTERRA  
TAILCONE SKIN FORMING  
FIGURE 07-03**

1:1 TEMPLATE

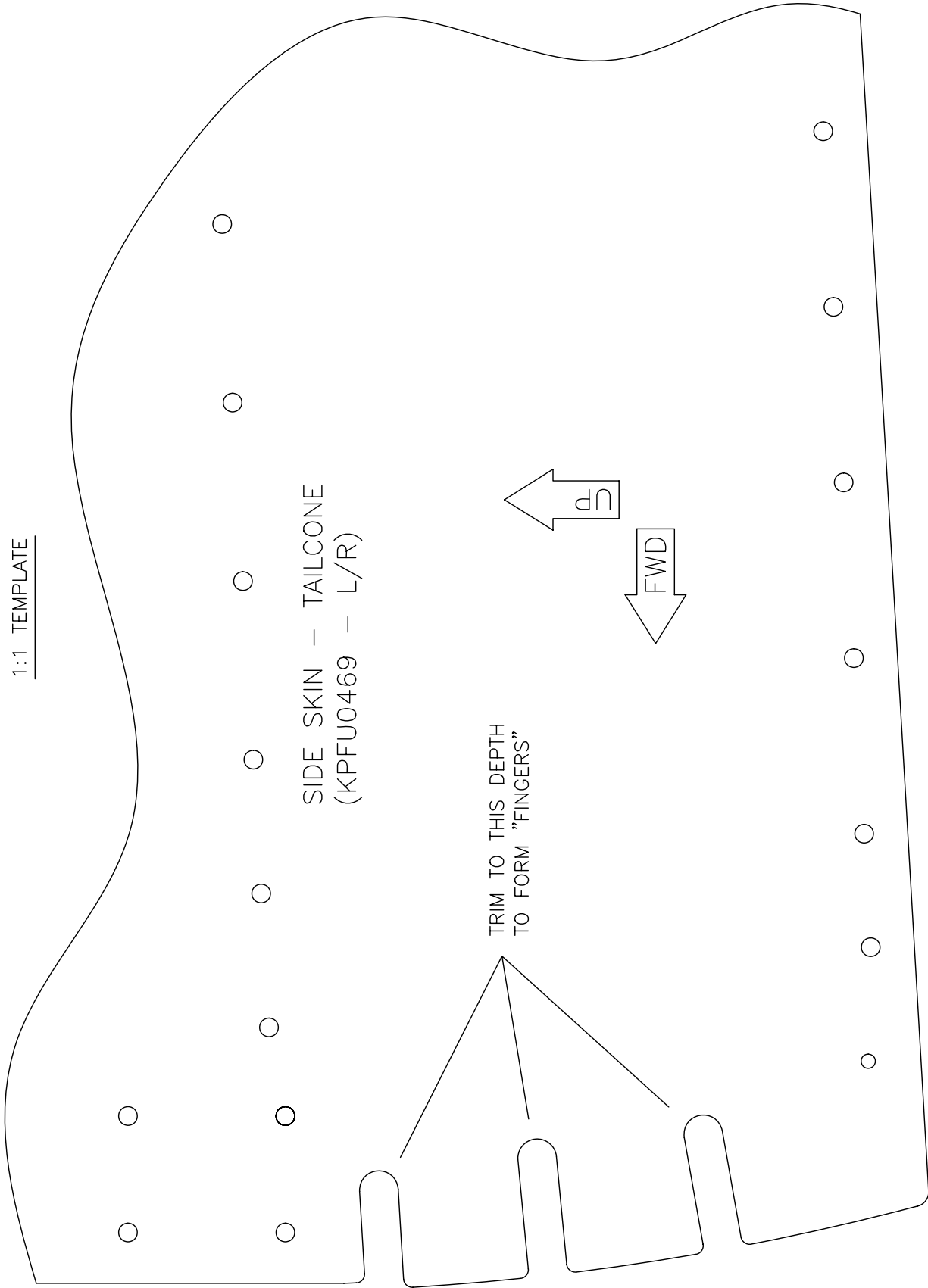

MD4836

**RAMS S-19 VENTERRA**  
**FUSELAGE TAILCONE SIDE SKIN MODIFICATION**  
**FIGURE 07-04**

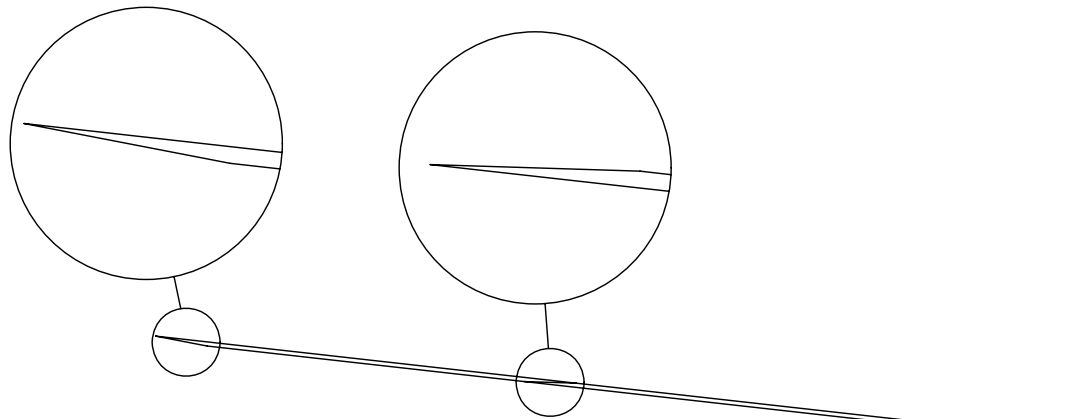

VIEW FROM TOP

TAPER OUTSIDE OF GUSSET 1/2" TO ALLOW FOR A FLUSH FIT WITH FUSELAGE SIDE SKIN.

KPFU0494-L/R

TAPER INSIDE OF GUSSET 1/2" TO ALLOW FOR A SMOOTH TRANSITION OF STRINGER FROM GUSSET TO SIDE SKIN.

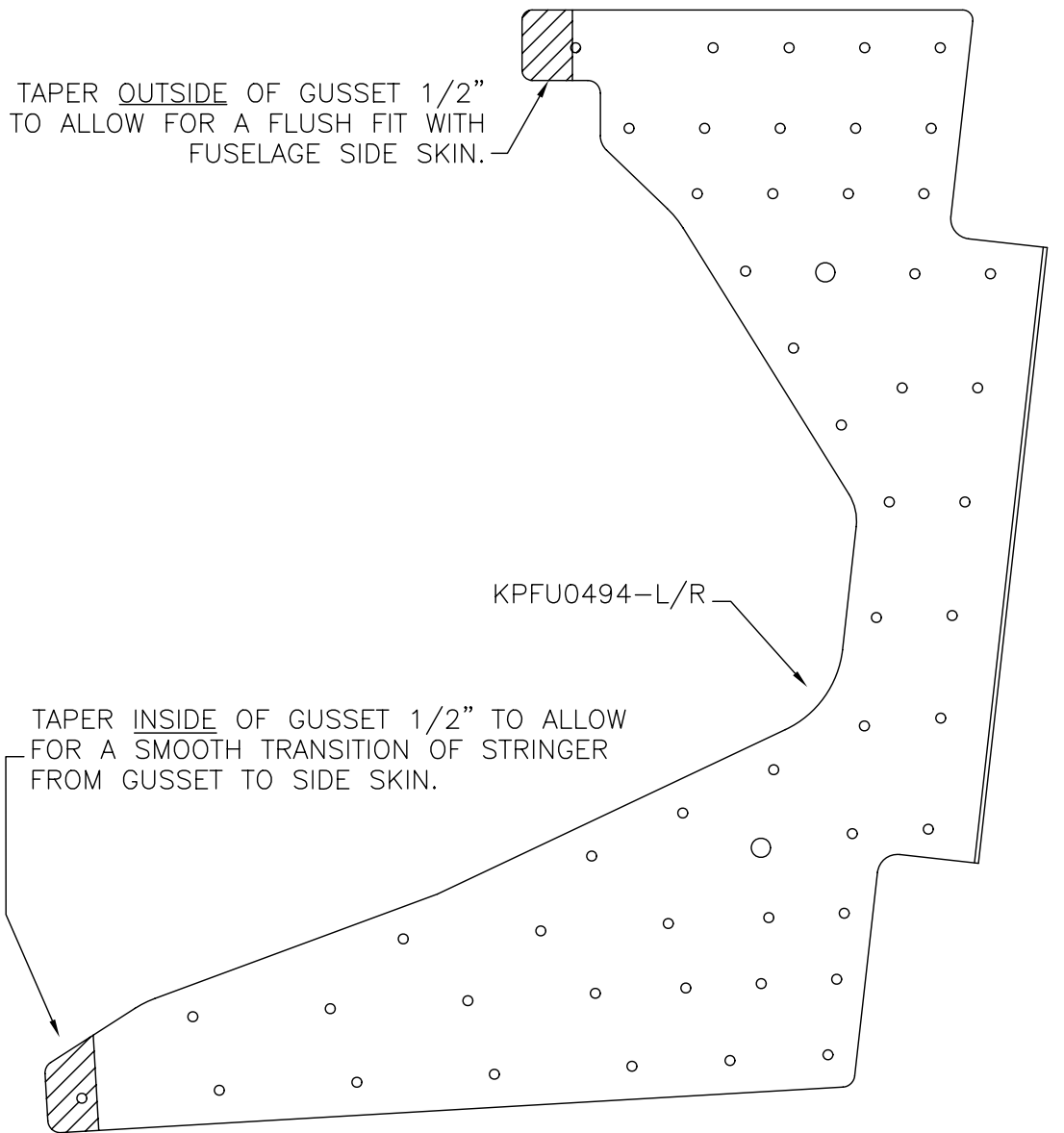

RIGHT HAND SHOWN

MD4931

**RANS S-19 VENTERRA**  
**REAR BULKHEAD SIDE STIFFENER**  
**FIGURE 07-06**

04/01/2011

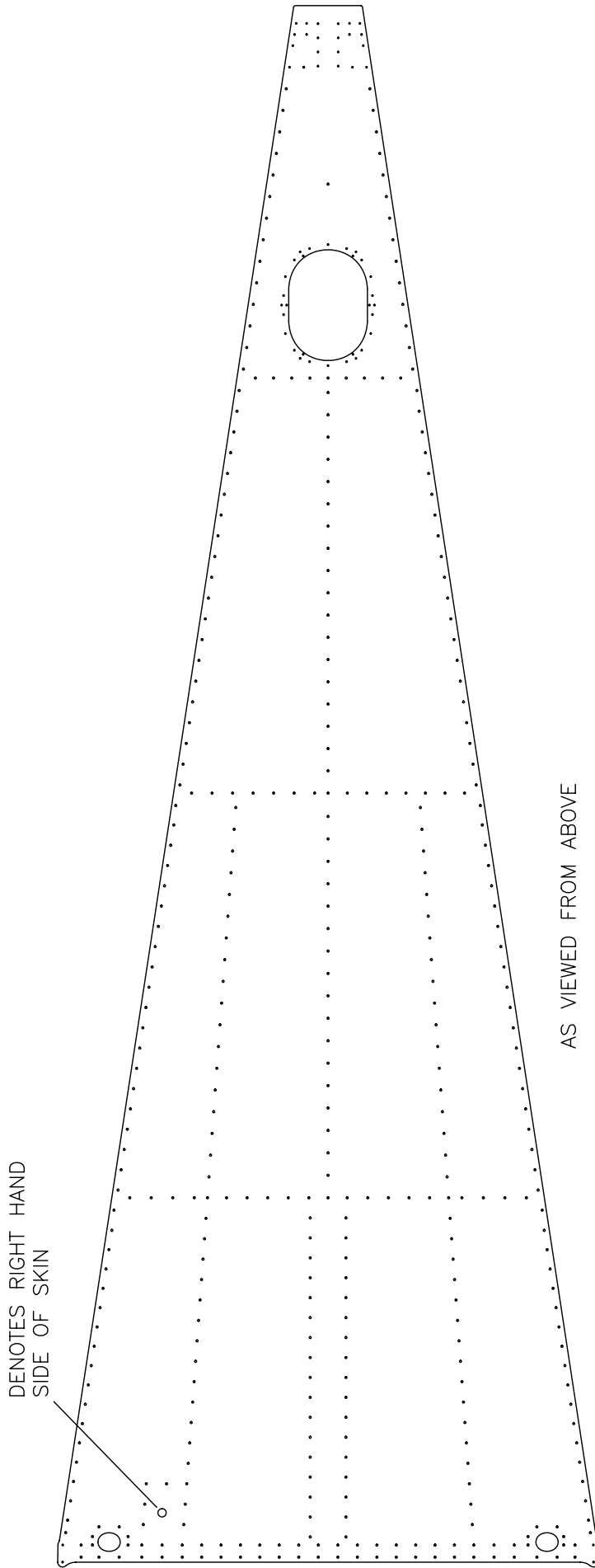

MD5525

**RRMO S-19 VENTERRA**  
**TAILCONE BELLY SKIN ORIENTATION**  
**FIGURE 07-09**

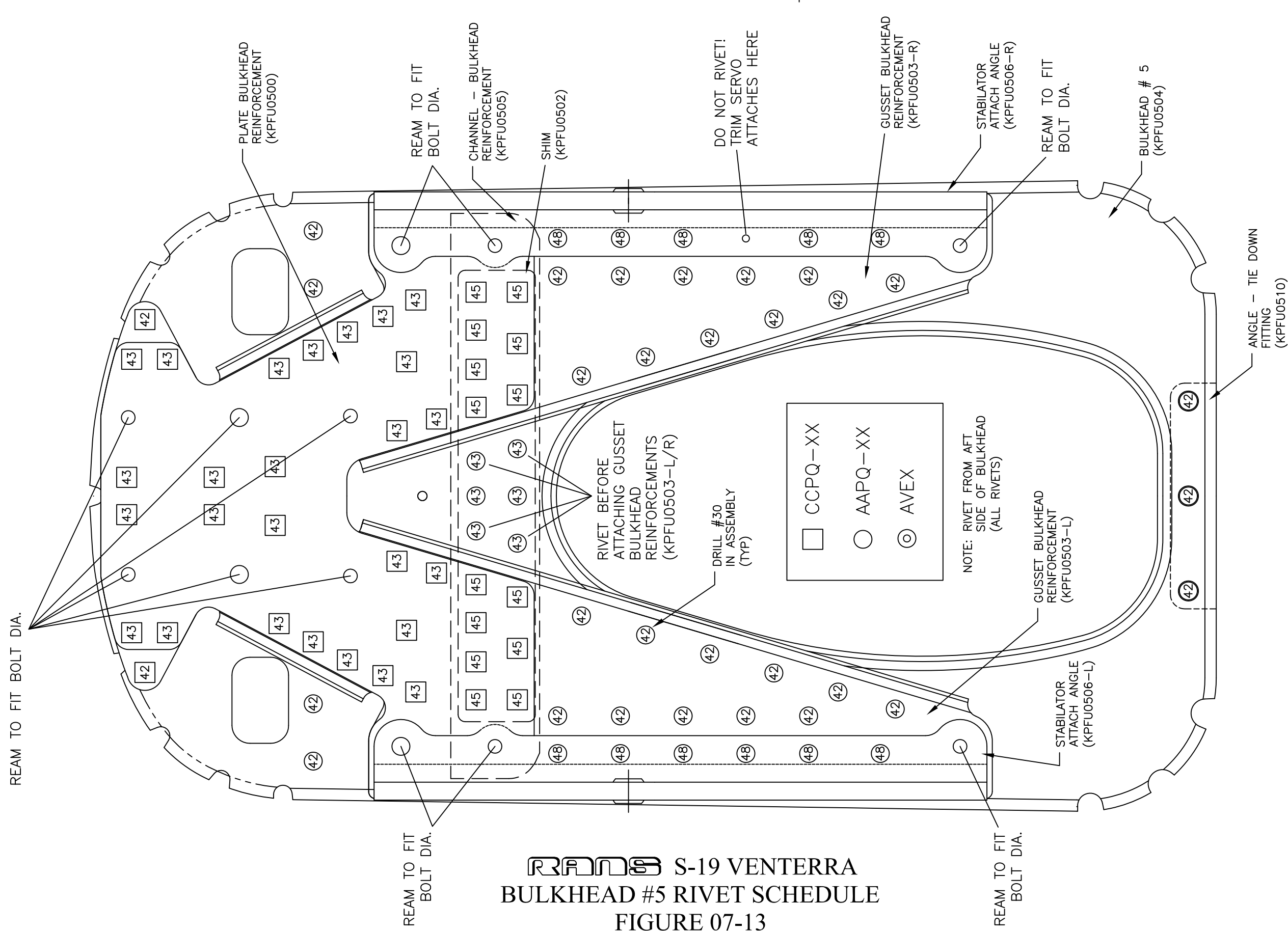

**RANS S-19 VENTERRA**  
**BULKHEAD #5 RIVET SCHEDULE**  
**FIGURE 07-13**

**IMPORTANT:** ALL PARTS ARE FINAL DRILLED OR REAMED TOGETHER IN ASSEMBLY. TIGHT FIT OF BOLTS IS REQUIRED. USE CARE WHEN DRILLING OR REAMING.

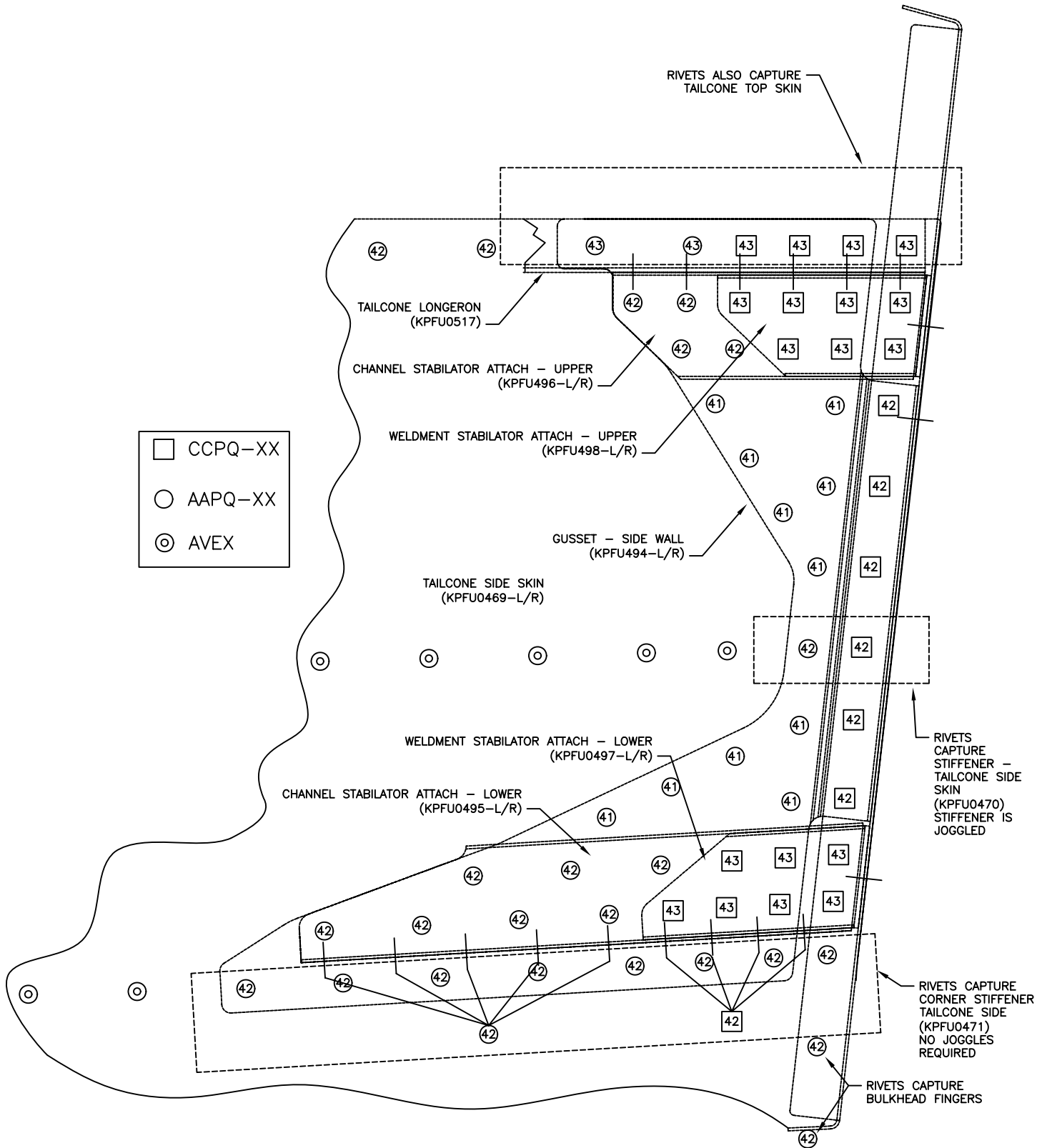

MD4994

**RAMS S-19 VENTERRA**  
**AFT SIDE SKIN RIVET SCHEDULE**  
**FIGURE 07-15**

04/01/2011

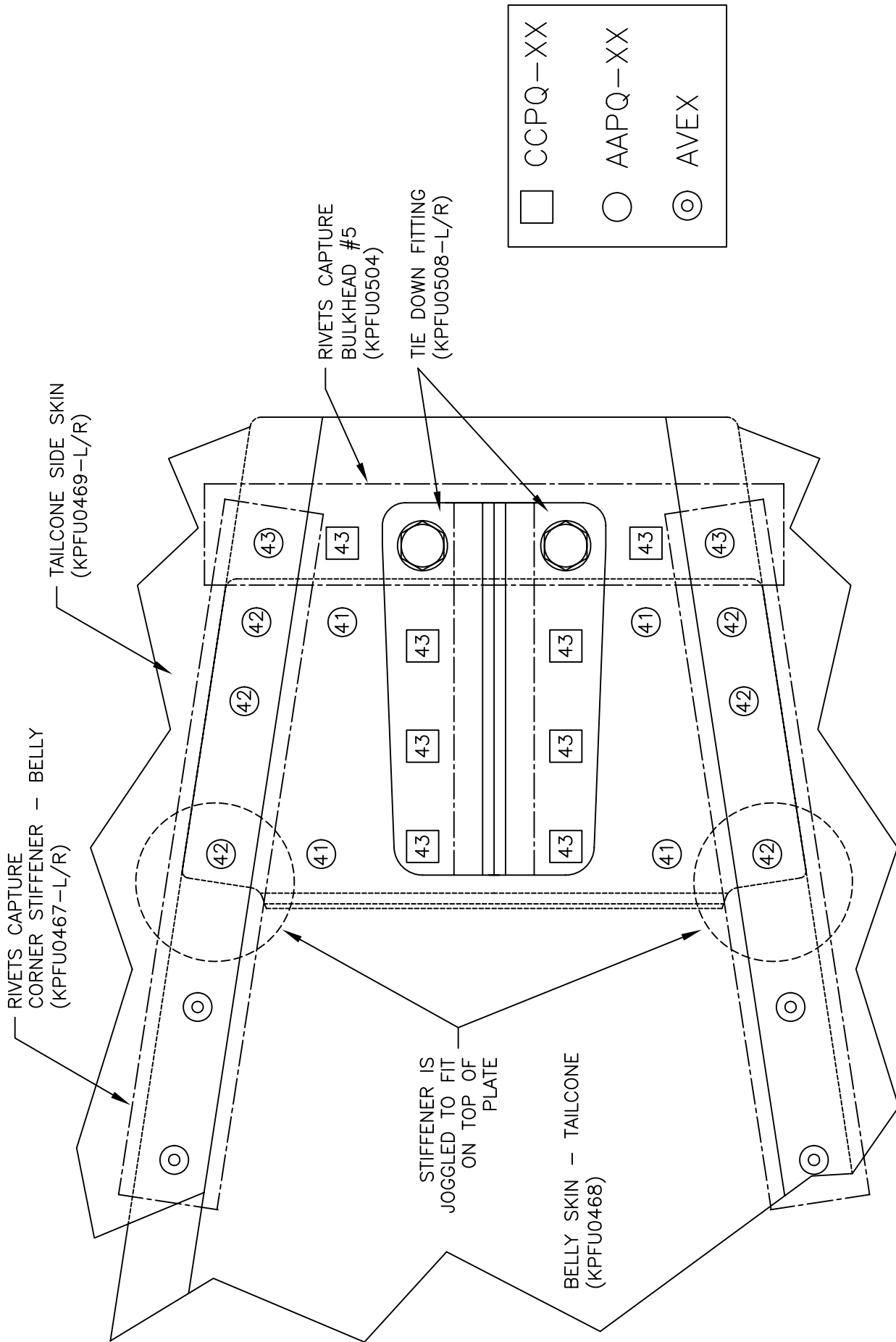

**RAVEN S-19 VENTERRA**  
**AFT BELLY SKIN RIVET SCHEDULE**  
**FIGURE 07-15A**



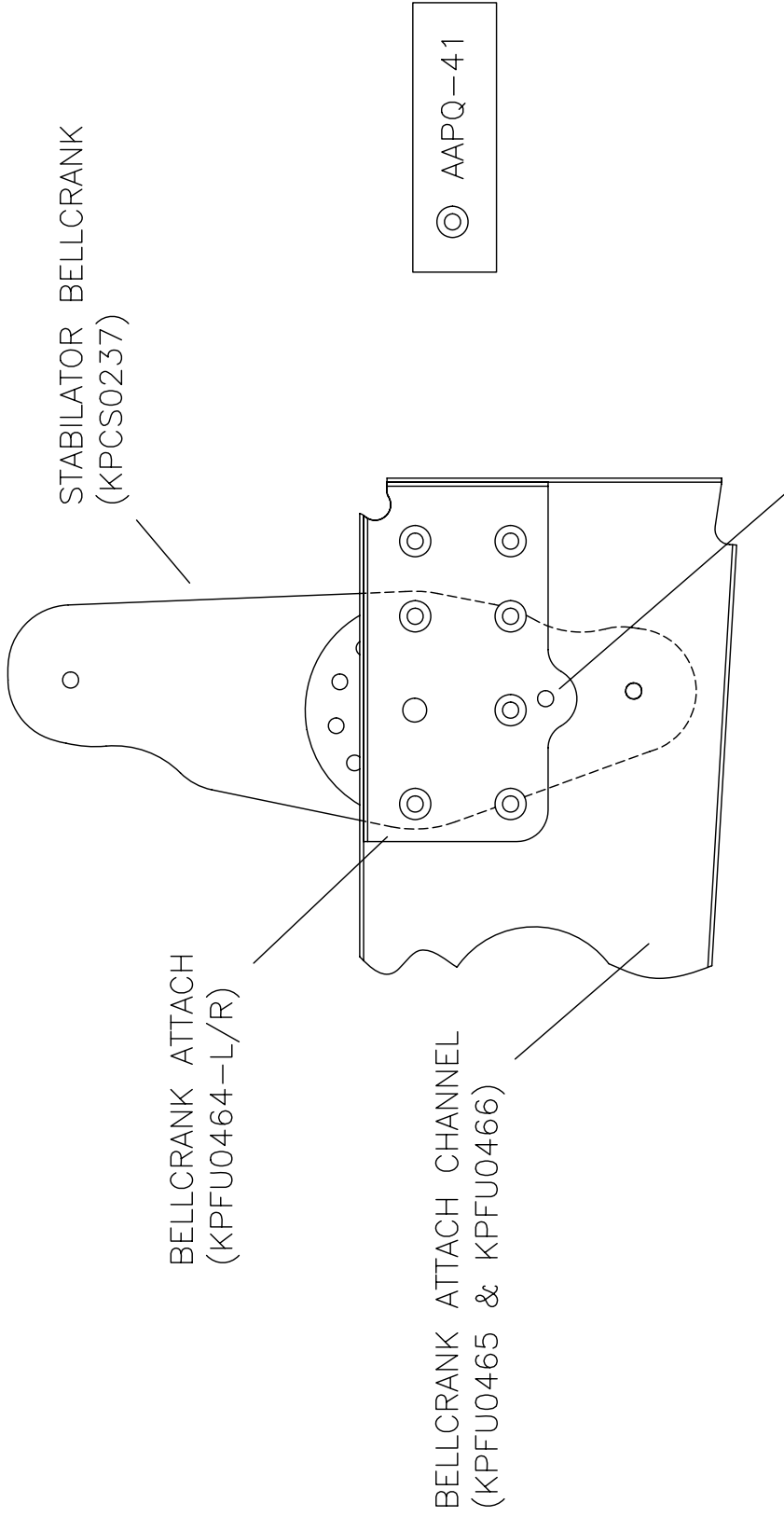

**RRR** S-19 VENTERRA  
**BELLCRANK ATTACH RIVET DETAIL**  
**FIGURE 07A-02**

LEGEND

- ⊕ AAPQ-41
- ⊗ 40APR1/8
- ⊕ AN526-832R6

OBLONG PANEL

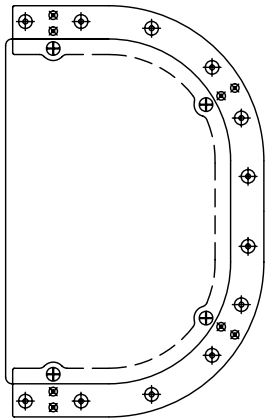

OVAL PANEL

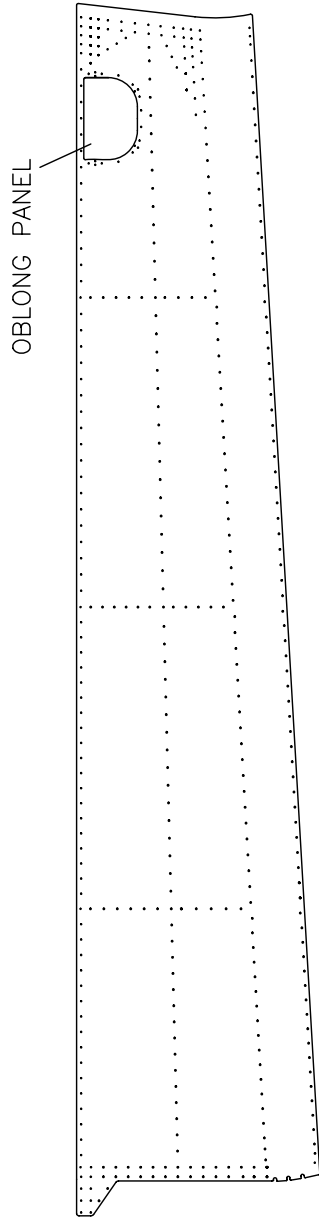
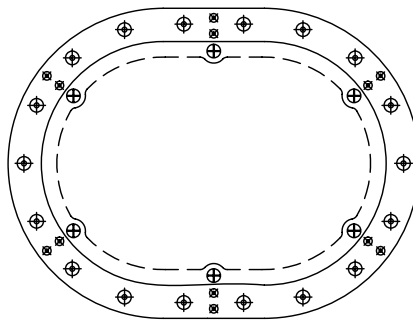

VIEWED FROM LEFT SIDE

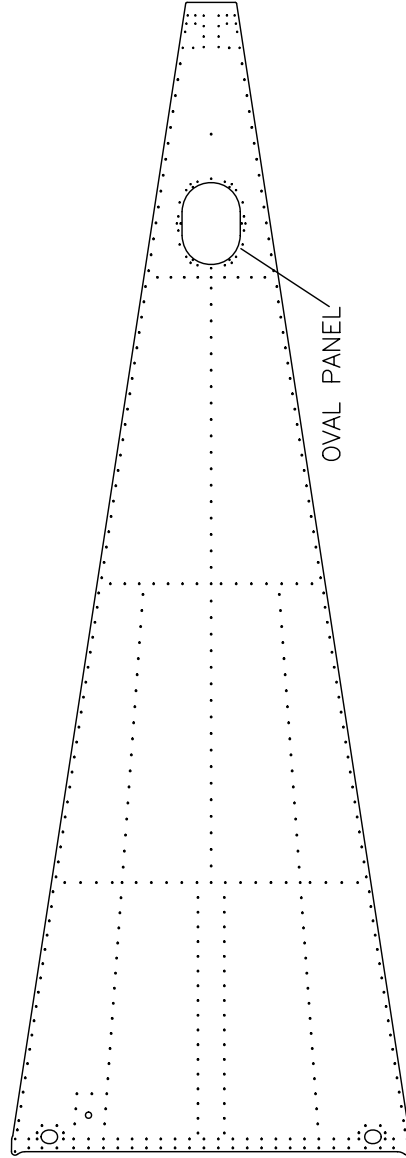

VIEWED FROM ABOVE

MD5027

**RAMS** S-19 VENTERRA  
INSPECTION PANEL INSTALLATION  
FIGURE 07B-06

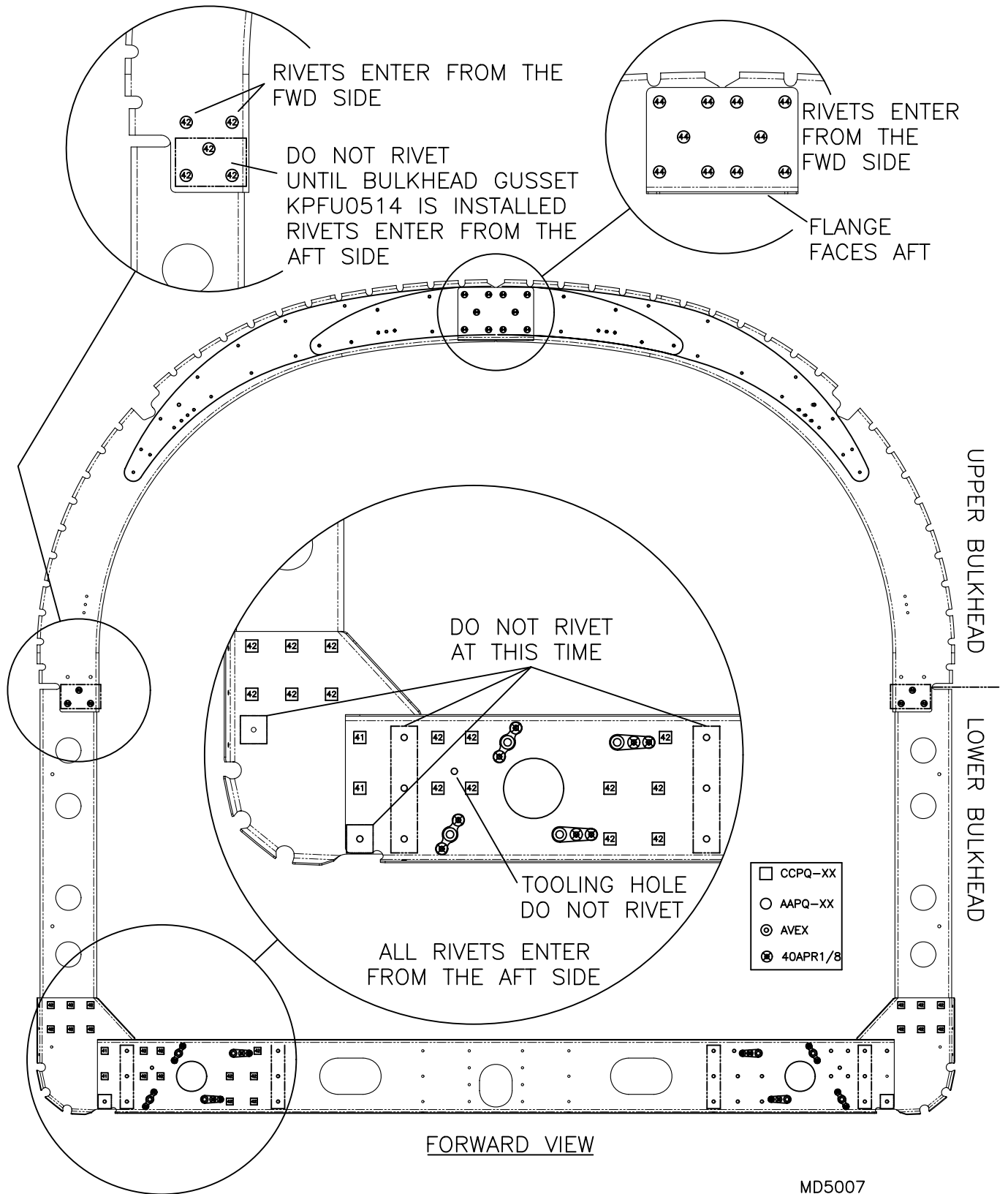

**RANS S-19 VENTERRA**  
**BULKHEAD #1 ASSEMBLY**  
**FIGURE 07C-02**

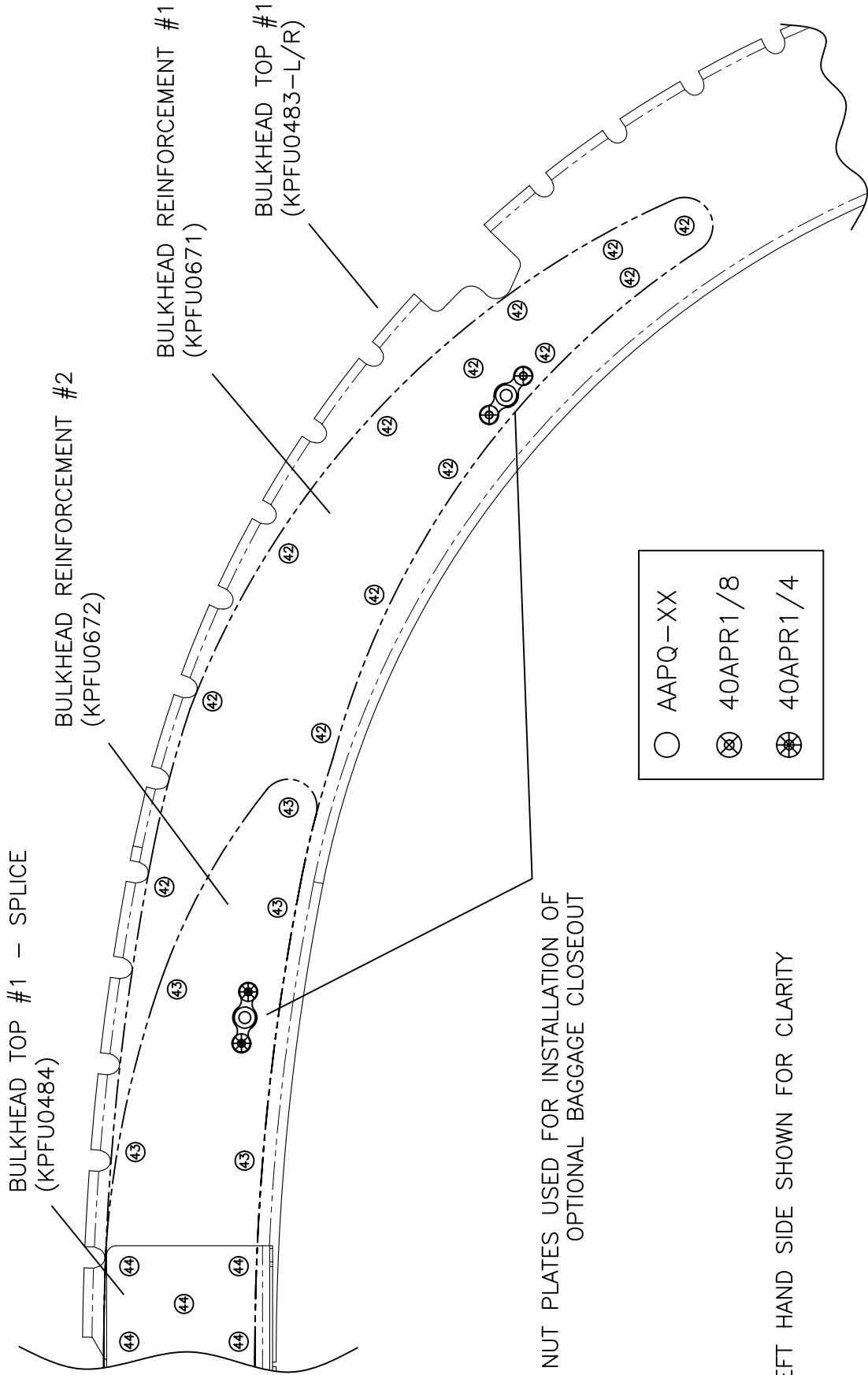

MD5007  
REV. A

**RAMS S-19 VENTERRA**  
**UPPER BULKHEAD #1 RIVET SCHEDULE**  
**FIGURE 07C-02A**

REMOVE TAB AS SHOWN  
2 PARTS ONLY (1L/1R)

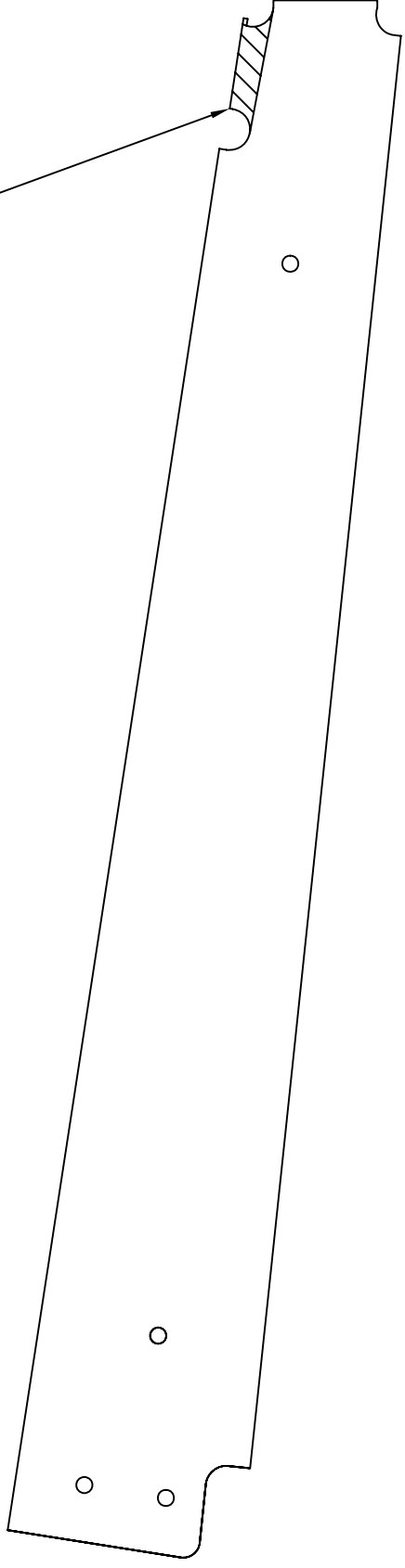

STIFFENER - SIDE WALL  
KPFU0473 - L/R

MD5008

**RAMMS** S-19 VENTERRA  
SIDEWALL STIFFENER MODIFICATION  
FIGURE 07C-04

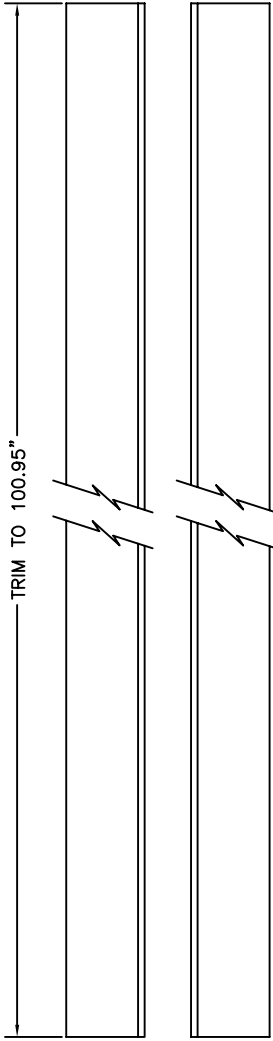

STEP 1.

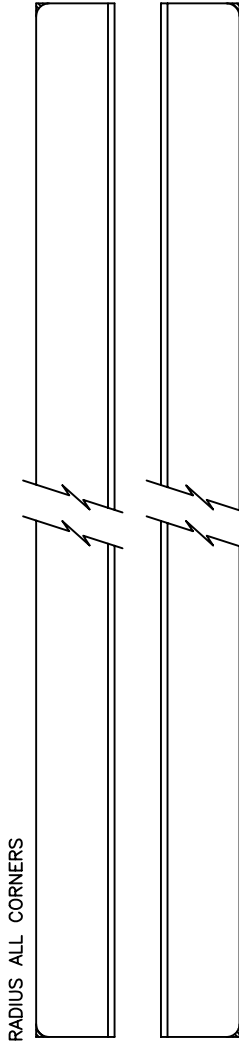

STEP 2. RADIUS ALL CORNERS

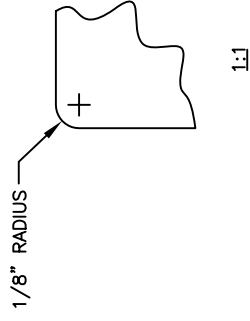

1:1

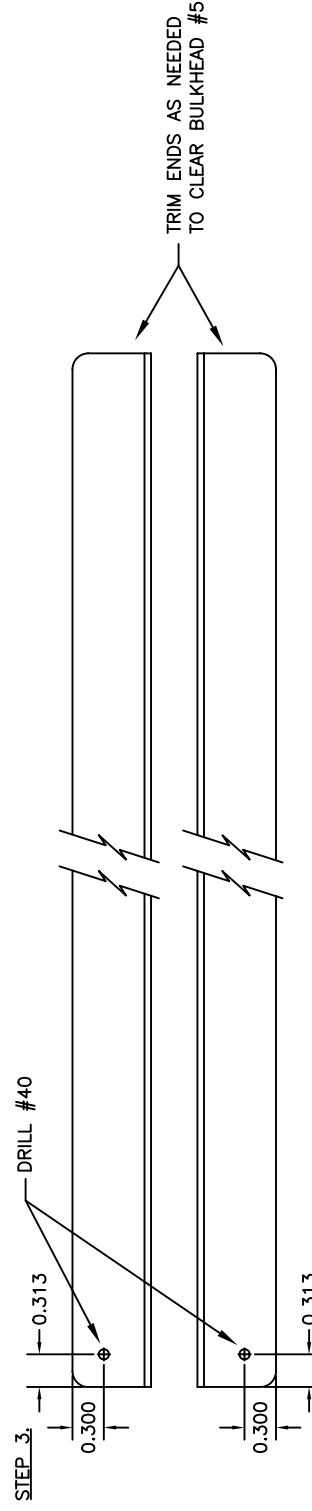

STEP 3.

**RAMS** S-19 VENTERRA  
 TAILCONE LONGERON  
 FIGURE 07D-02

MD4992

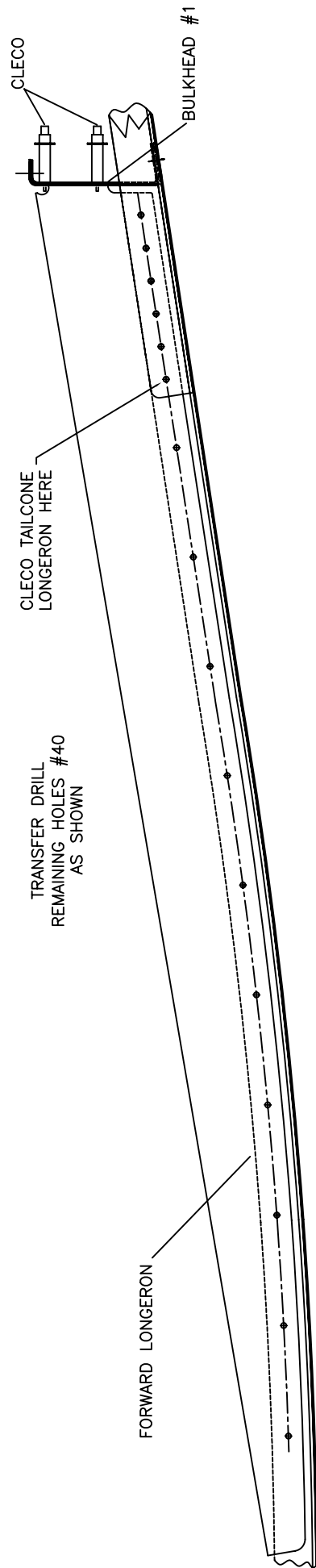

MD4998

**RRR** S-19 VENTERRA  
 TAILCONE LONGERON  
 FIGURE 07D-03

ALIGN WITH TOP OF SKIN  
AND CLAMP IN PLACE

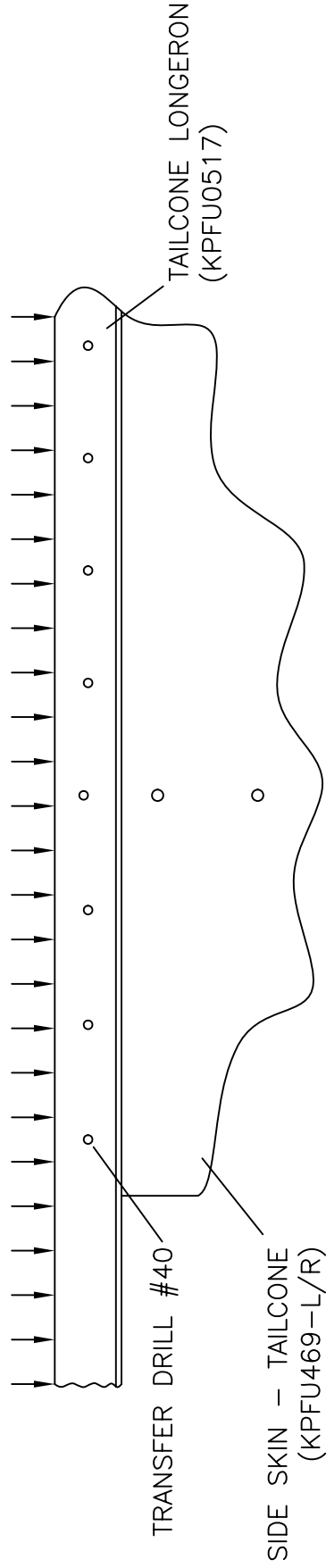

MD4998

**RAMROB** S-19 VENTERRA  
TAILCONE LONGERON  
FIGURE 07D-04



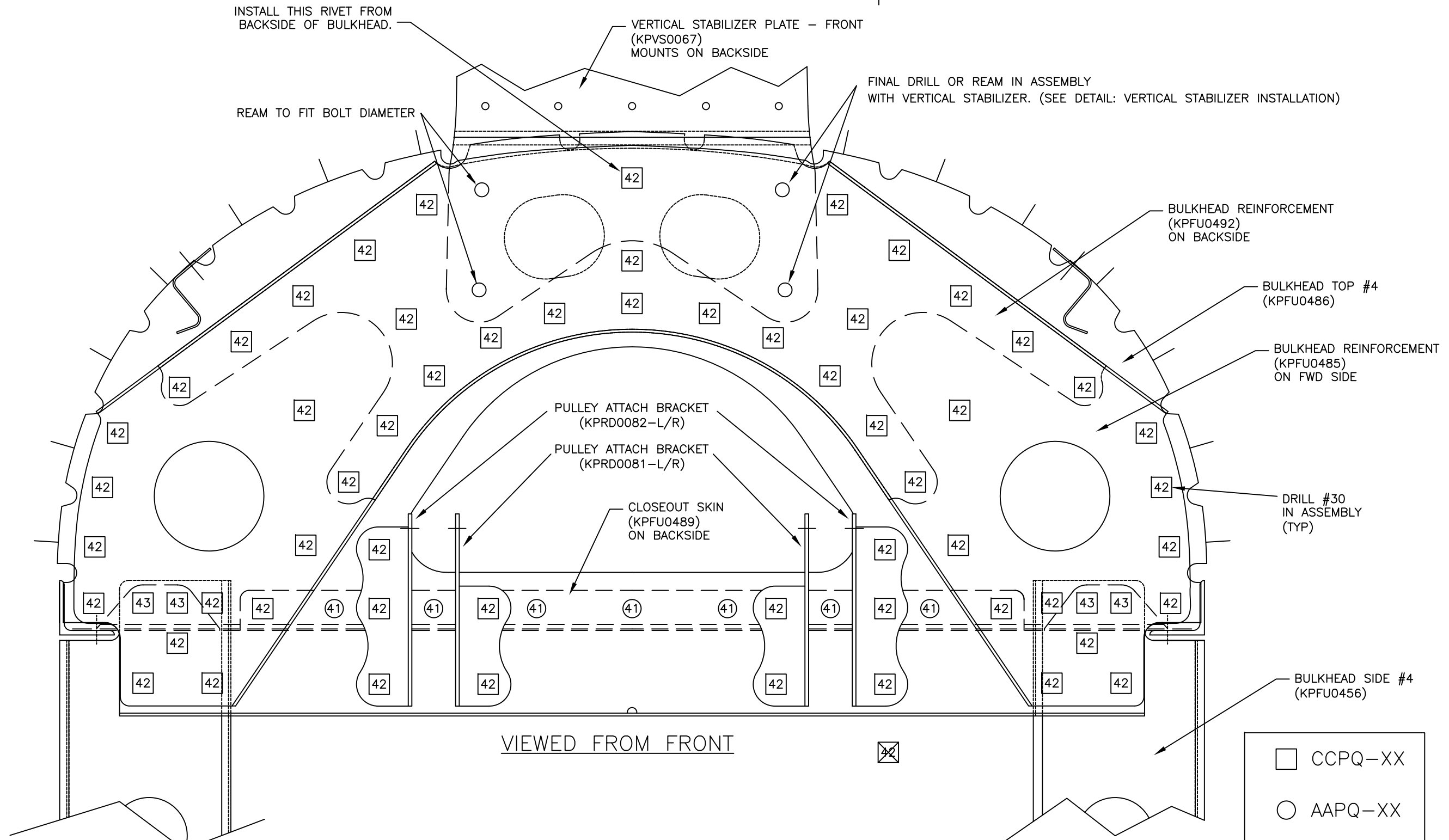

NOTE: ALL PARTS ARE FINAL DRILLED TOGETHER IN ASSEMBLY.  
 RIVET FROM FWD SIDE OF BULKHEAD (UNLESS OTHERWISE STATED)  
 BULKHEAD #4 TOP INSTALLS TO FWD SIDE OF BULKHEAD SIDES.

MD4996

**RANS S-19 VENTERRA**  
**BULKHEAD TOP #4 RIVET SCHEDULE**  
**FIGURE 07F-01**

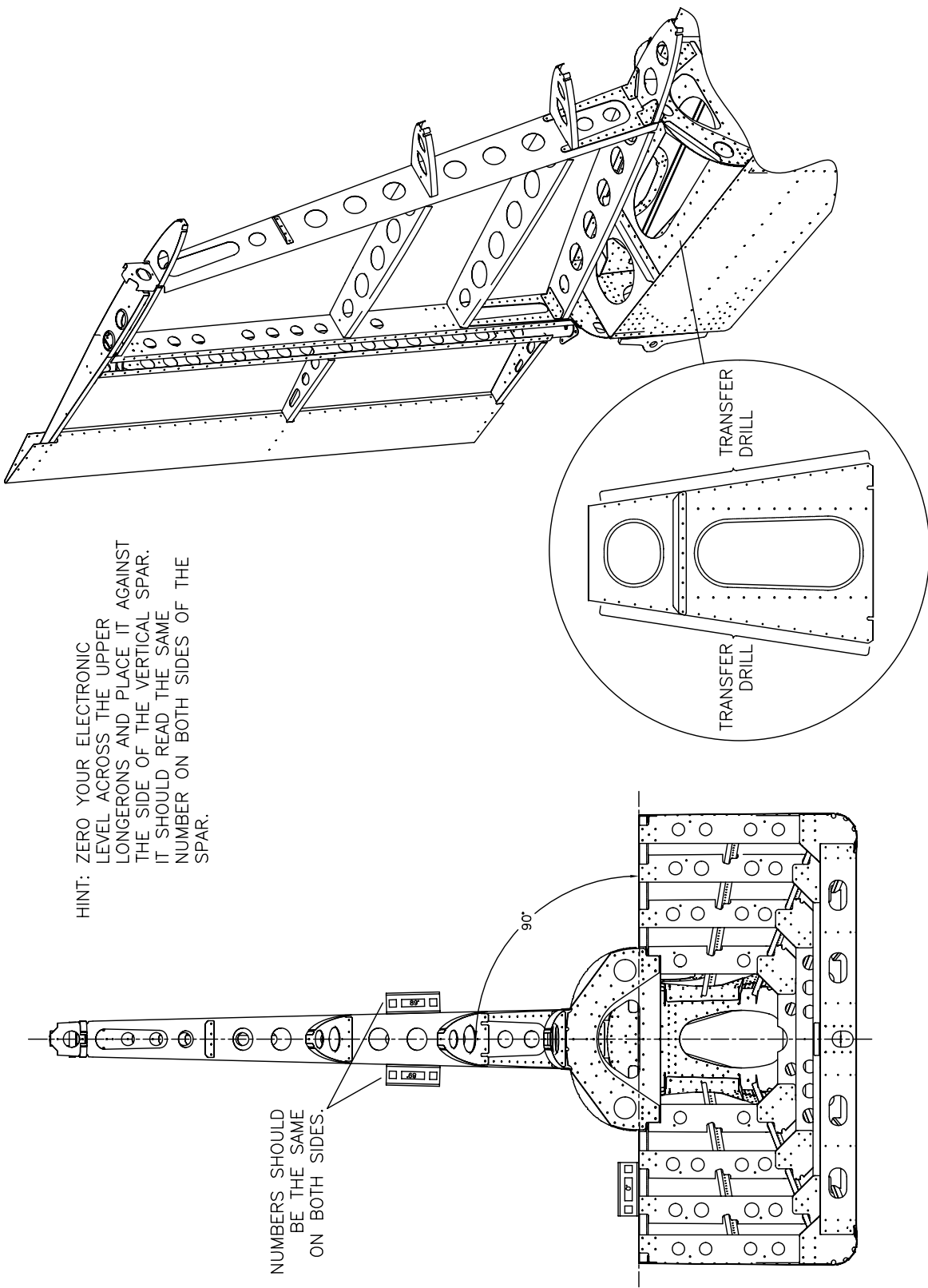

MD4930

**RAMMS S-19 VENTERRA**  
**VERTICAL STABILIZER ALIGNMENT**  
**FIGURE 07F-06**

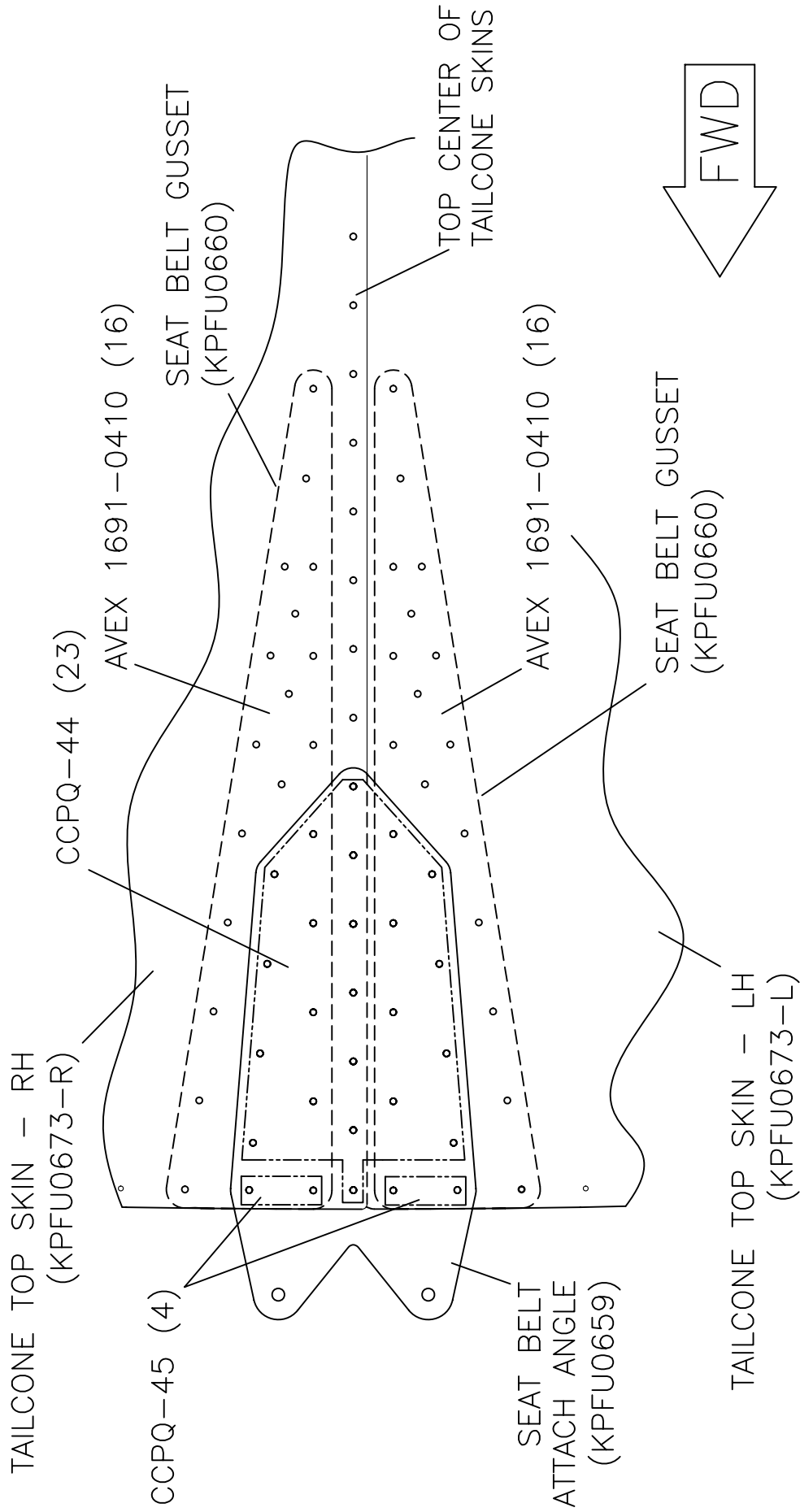

MD5227

**RAVEN S-19 VENTERRA**  
**SEAT BELT GUSSET**  
**FIGURE 07G-06**

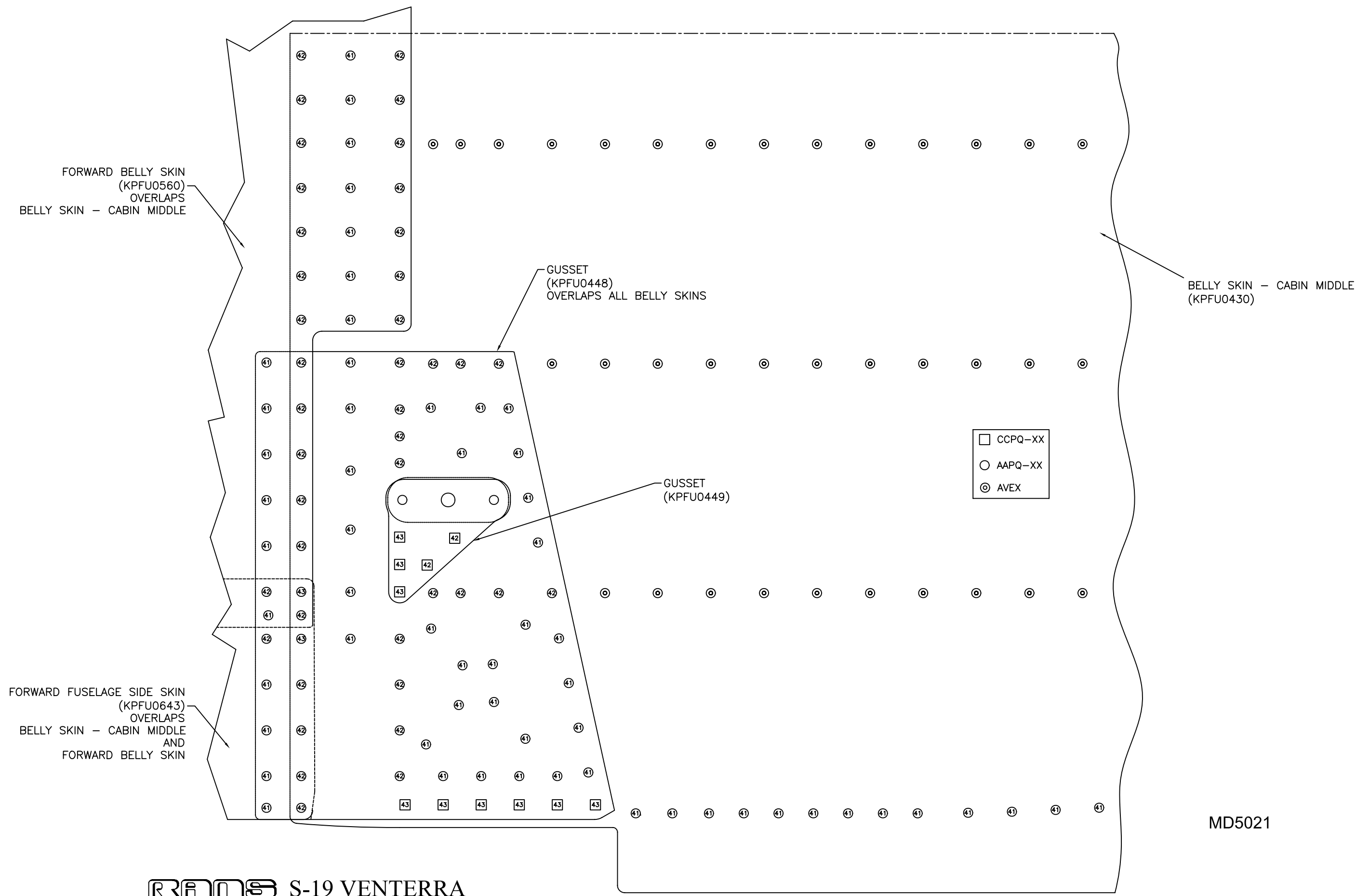

MD5021

**RAMS S-19 VENTERRA**  
**FWD FUSELAGE TO CENTER SECTION RIVET SCHEDULE**  
**FIGURE 07H-09**

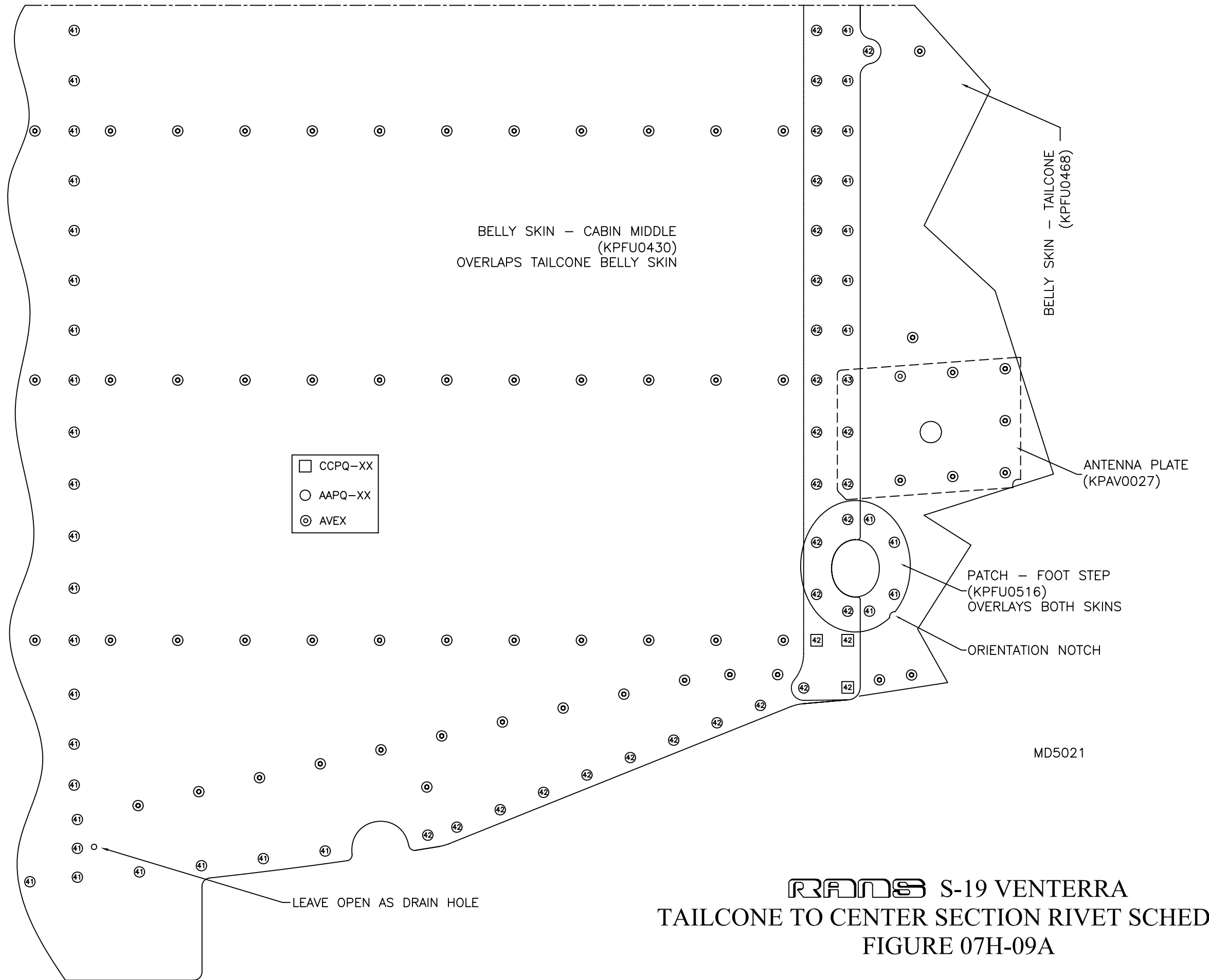

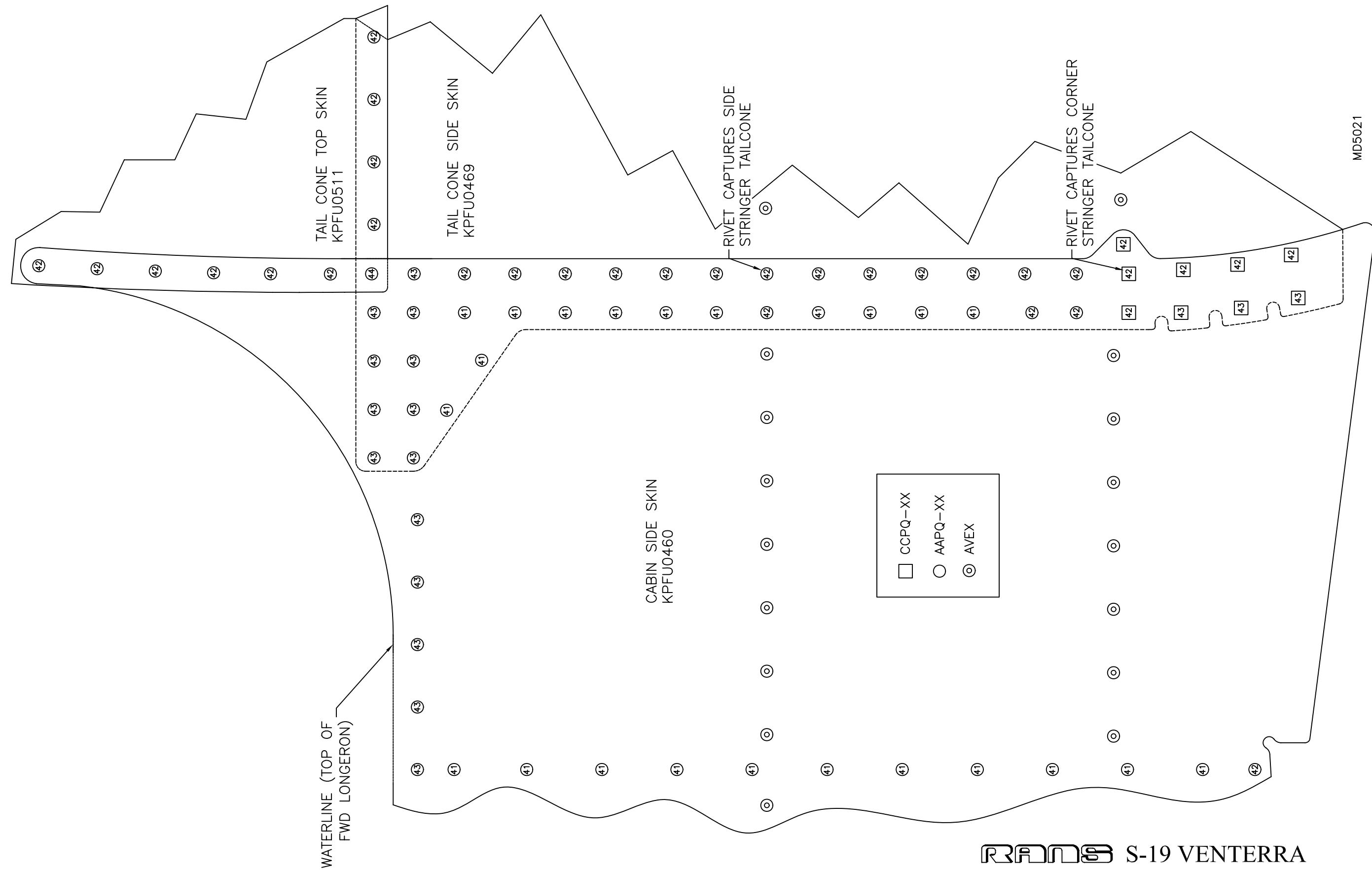

**RAMS S-19 VENTERRA**  
**TAILCONE TO CENTER SECTION RIVET SCHEDULE**  
**FIGURE 07H-09B**

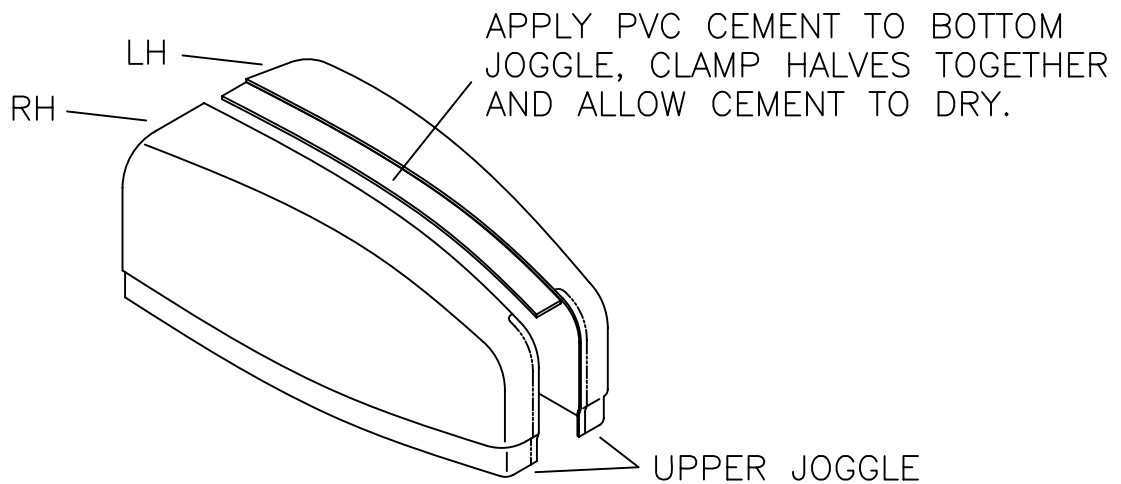
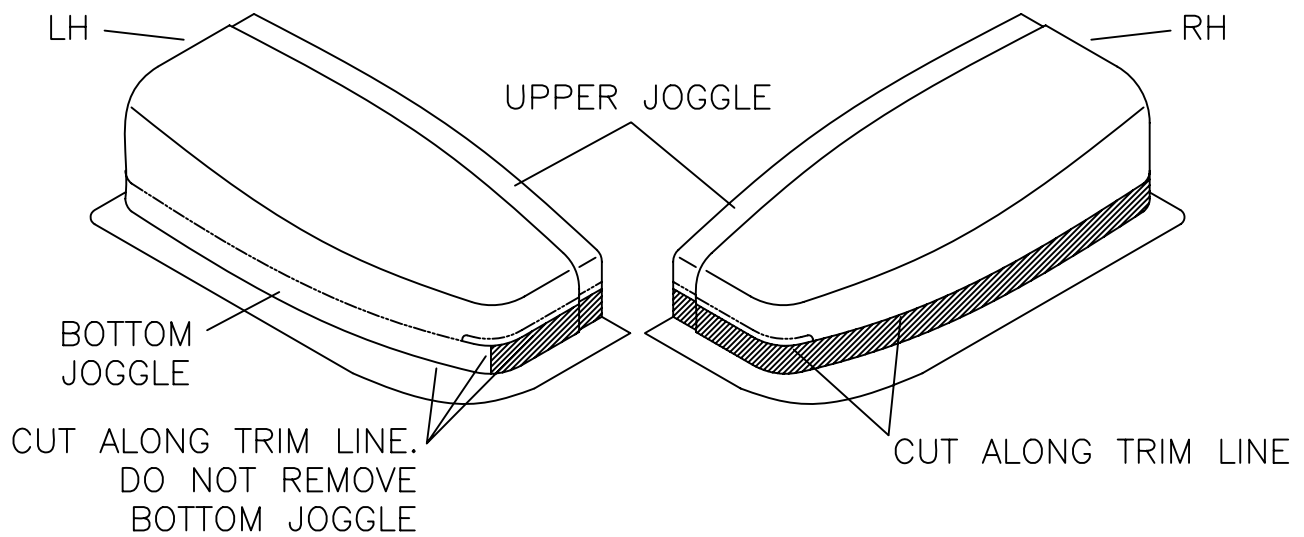
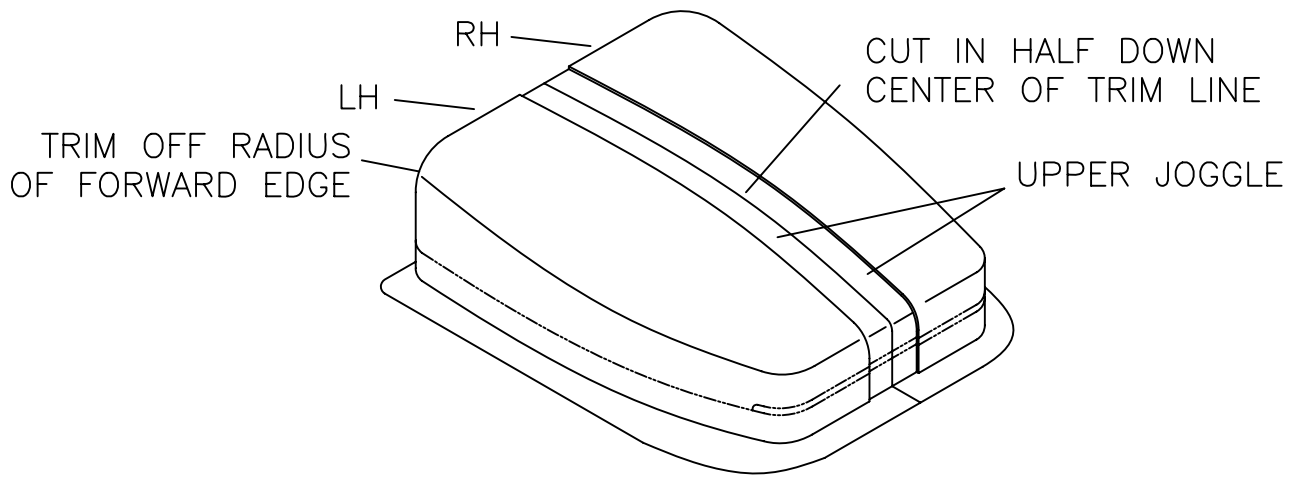

**RANS S-19 VENTERRA**  
**LOWER TAILCONE STINGER TRIMMING**  
**FIGURE 07I-02**

MD5474

04/01/2011

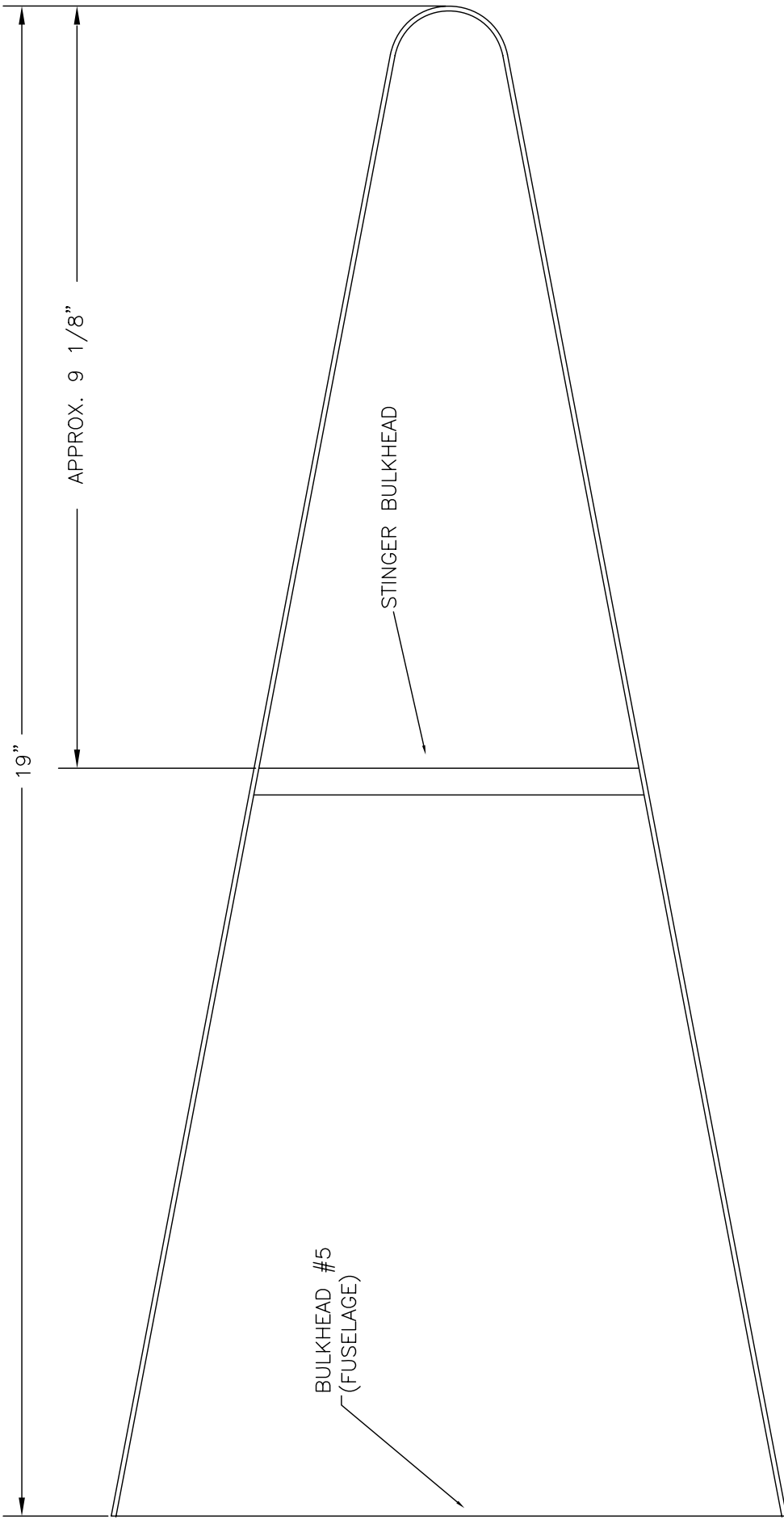

TOP VIEW OF LOWER STINGER

MD5477

**RAMS** S-19 VENTERRA  
TAILCONE STINGER  
FIGURE 07I-03



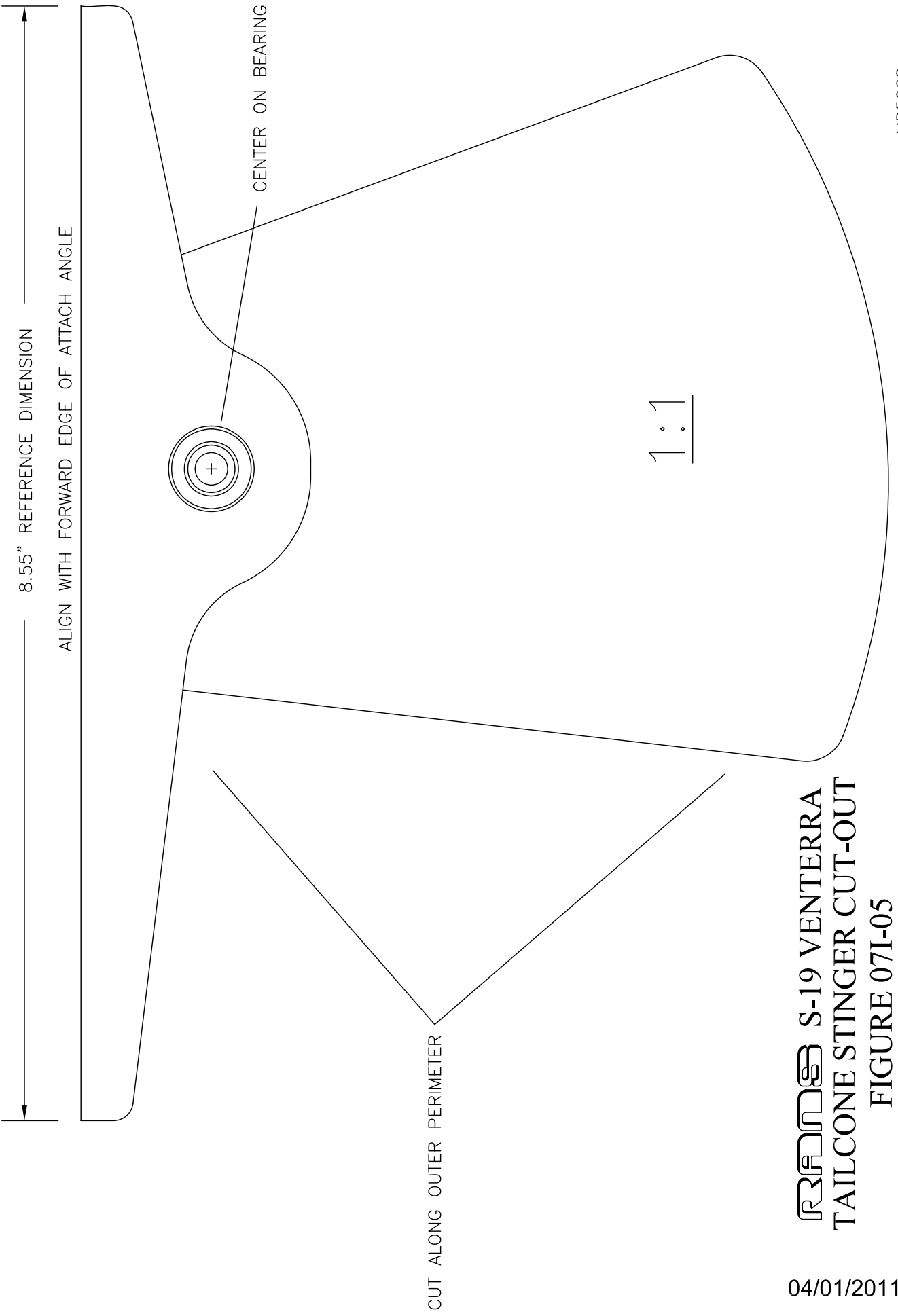

8.55" REFERENCE DIMENSION

ALIGN WITH FORWARD EDGE OF ATTACH ANGLE

CENTER ON BEARING

1:1

CUT ALONG OUTER PERIMETER

**RRR** S-19 VENTERRA  
 TAILCONE STINGER CUT-OUT  
 FIGURE 07I-05

04/01/2011

MD5028

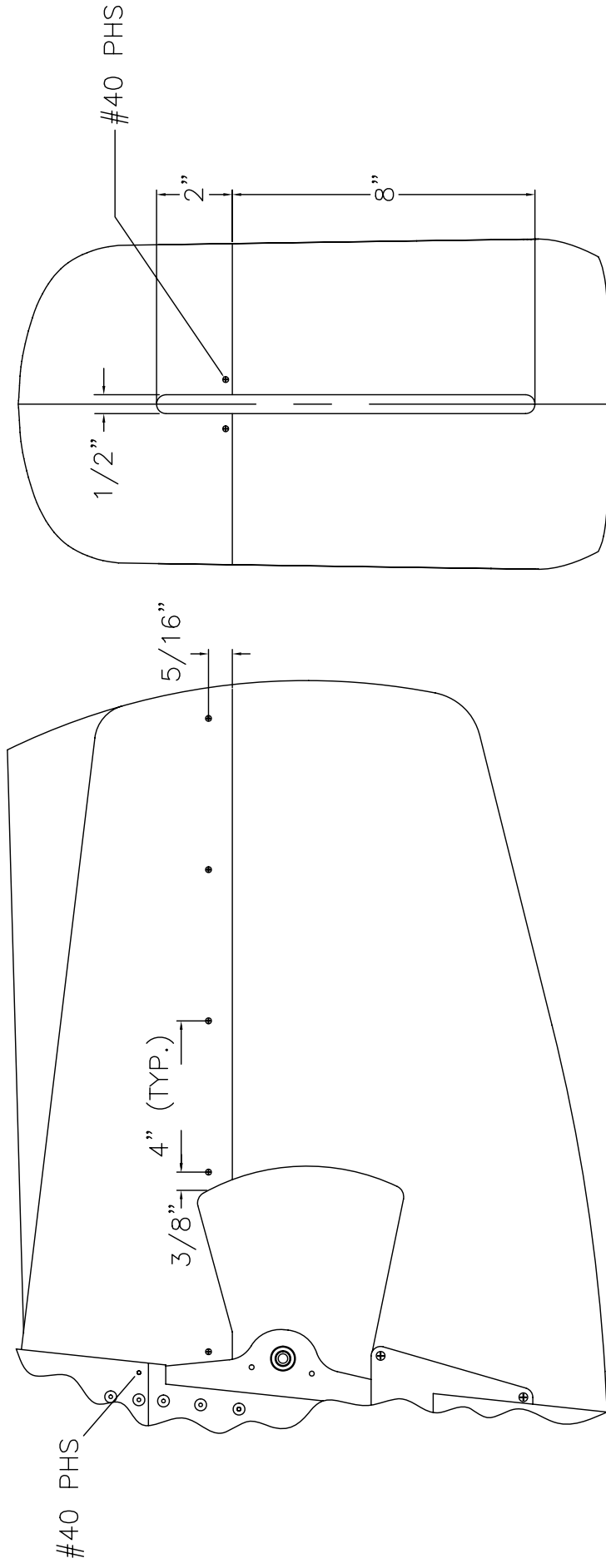

MD5218

**RAMMS S-19 VENTERRA**  
**STINGER ATTACH**  
**FIGURE 07I-06**

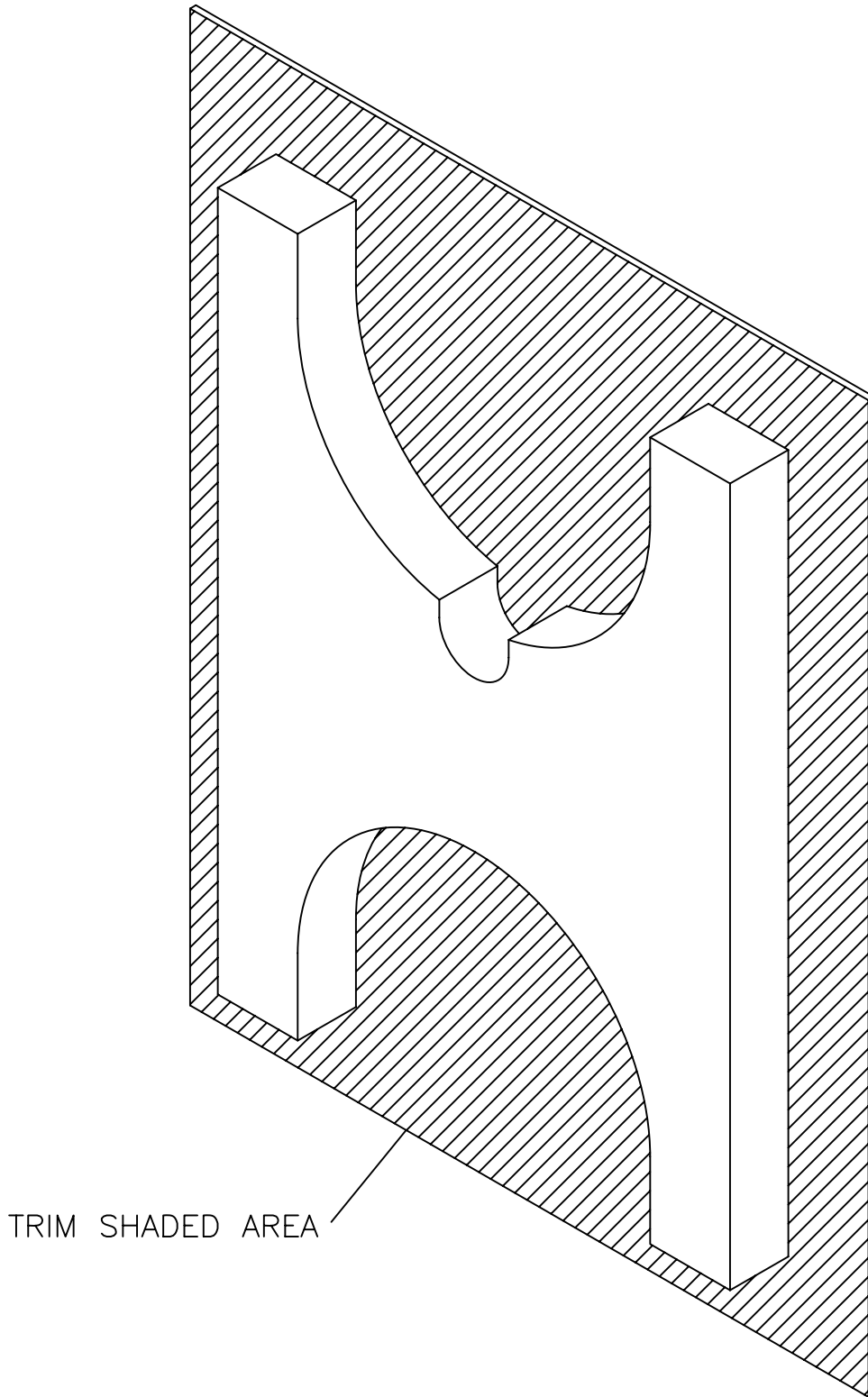

MD5478

**RAMS S-19 VENTERRA**  
**TAILCONE STINGER BULKHEAD TRIMMING**  
**FIGURE 07I-09**

04/01/2011

## 08 – FUSELAGE – SYSTEMS

FORWARD PUSH-PULL TUBE – STABILATOR .....	08-02
CONTROL STICK TORQUE TUBE ROD END SETTING .....	08-03
TYPICAL BELLCRANK ASSEMBLY .....	08-09
AFT PUSH-PULL TUBE – STABILATOR .....	08-12
STABILATOR DOWN BUNGEE RIGGING INSTRUCTIONS.....	08-17
SEAT BELT ATTACH TANG MODIFICATION .....	08B-03
FLAP RELEASE TUBE ASSEMBLY.....	08B-08
TRIM SERVO ATTACH .....	08C-02
TRIM TAB PUSH-PULL TUBE.....	08C-10
OPTIONAL VENT TEMPLATE .....	08D-02
OPTIONAL VENT TEMPLATE LOCATION.....	08D-03

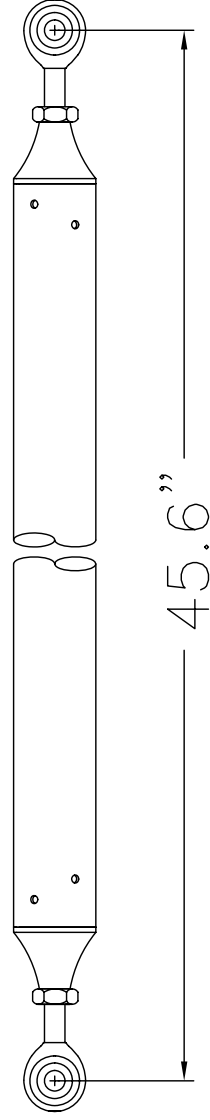

CAUTION:  
ROD ENDS MUST BE ENGAGED  
A MINIMUM OF 10 FULL THREADS

**RAMMS S-19 VENTERRA**  
**FORWARD PUSH-PULL TUBE - STABILATOR**  
**FIGURE 08-02**

MD5080

CAUTION:  
ROD ENDS MUST BE ENGAGED  
A MINIMUM OF 10 FULL THREADS

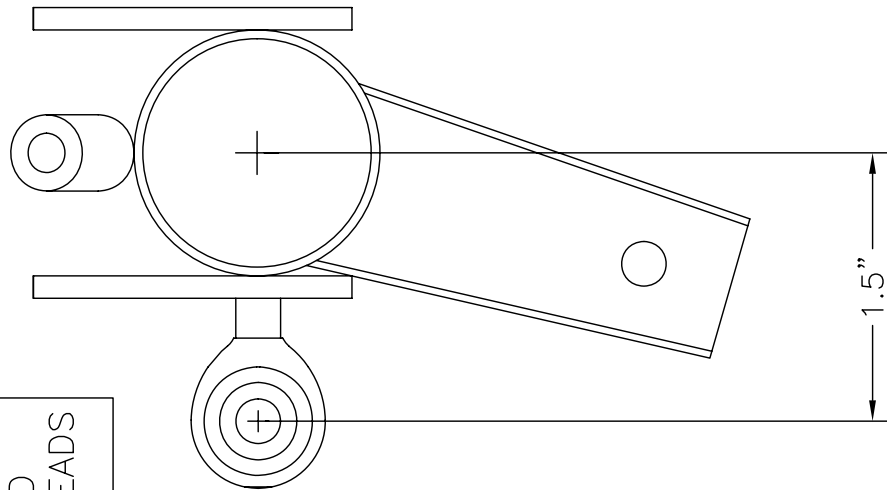

**RAMMED S-19 VENTERRA**  
**CONTROL STICK TORQUE TUBE ROD END SETTING**  
**FIGURE 08-03**

MD5080

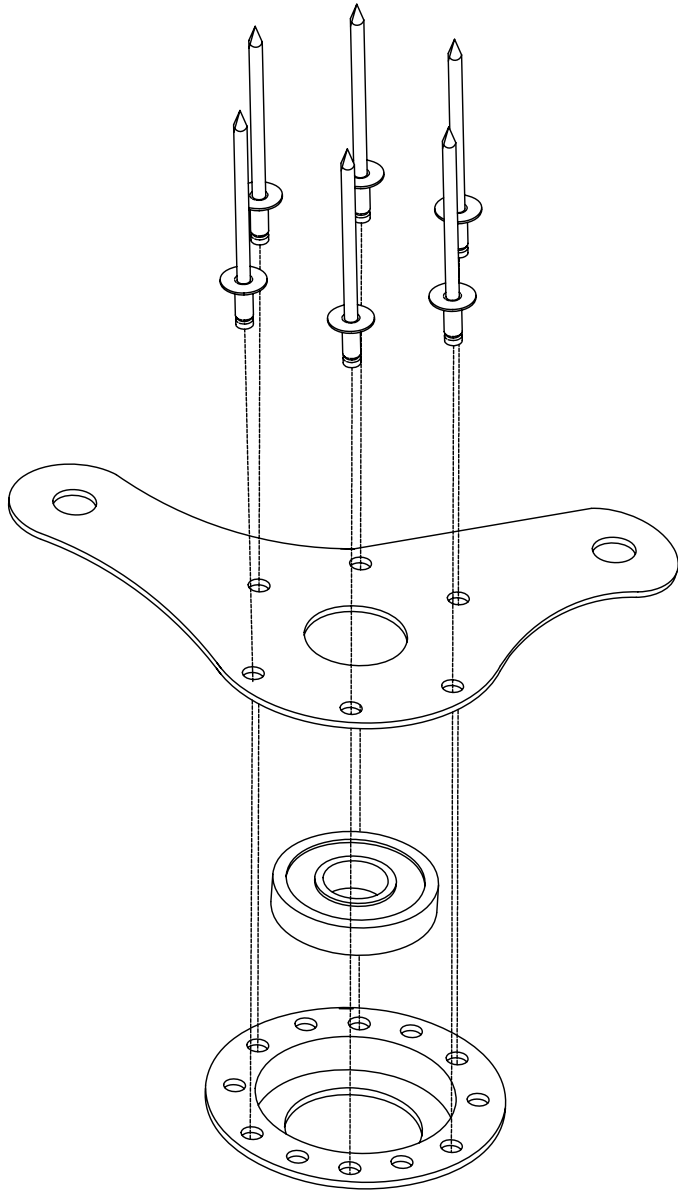

TYPICAL FOR ALL BELLCRANK ASSEMBLIES

**RANS S-19 VENTERRA**  
**TYPICAL BELLCRANK ASSEMBLY**  
**FIGURE 08-09**

MD4886

04/01/2011

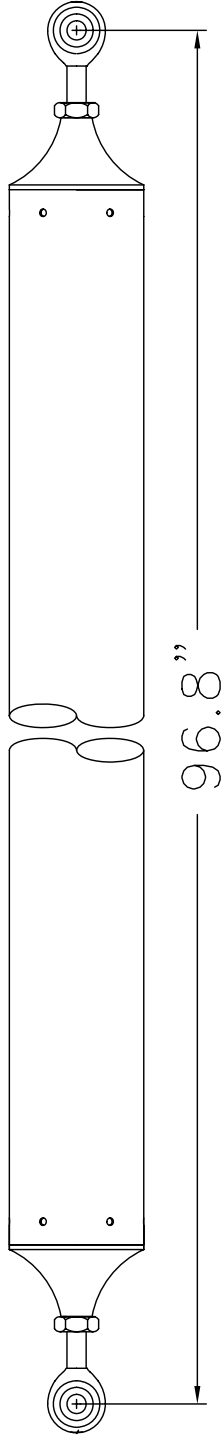

CAUTION:  
ROD ENDS MUST BE ENGAGED  
A MINIMUM OF 10 FULL THREADS

**RRANOS S-19 VENTERRA**  
**AFT PUSH-PULL TUBE - STABILATOR**  
**FIGURE 08-12**



POSITION ATTACH TANG TO  
 PUSH-PULL TUBE TO CLEAR AFT  
 SIDE OF CARRY-THRU WITH  
 CONTROL STICK ALL THE WAY BACK.

CHECK AND ADJUST FOR CORRECT  
 DOWN FORCE.

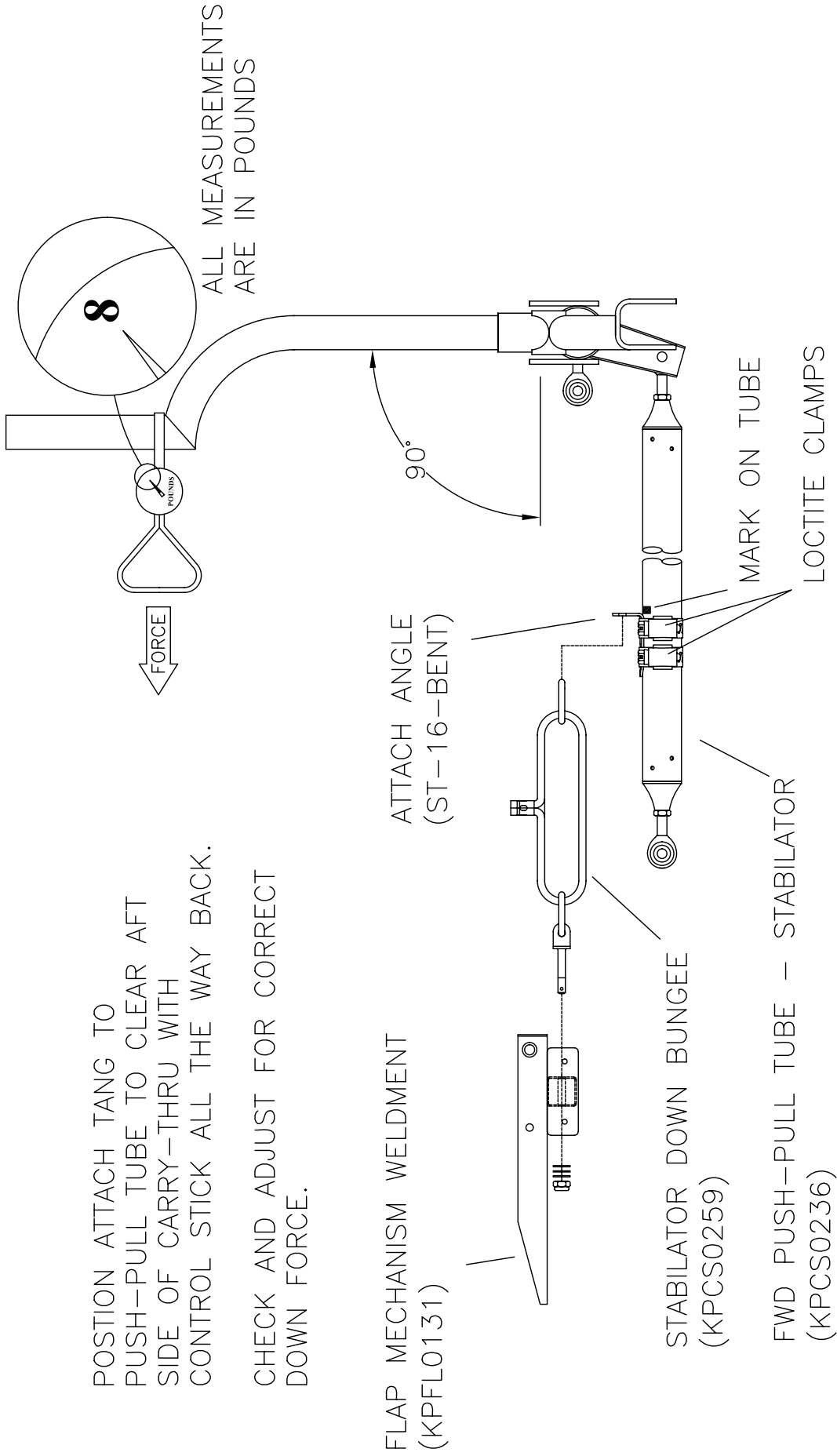

**RRAMES S-19 VENTERRA**  
**STABILATOR DOWN BUNGEE RIGGING INSTRUCTIONS**  
**FIGURE 08-17**

HUMMERTANG  
(T12-HT6)

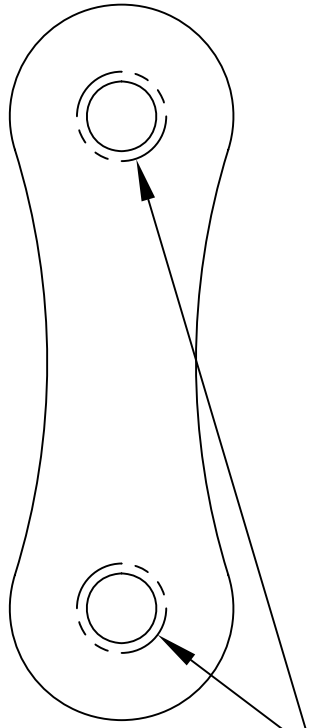

NOT TO SCALE

DRILL TO 1/4"  
AND DEBURR

MD5222

**RAMS** S-19 VENTERRA  
SEAT BELT ATTACH TANG MODIFICATION  
FIGURE 08B-03

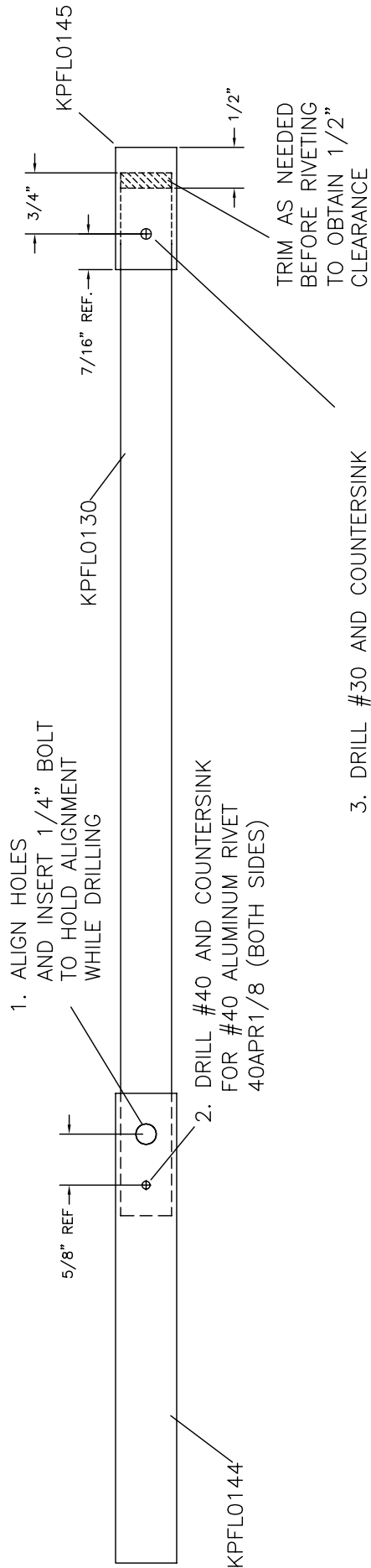

1. ALIGN HOLES AND INSERT 1/4" BOLT TO HOLD ALIGNMENT WHILE DRILLING

2. DRILL #40 AND COUNTERSINK FOR #40 ALUMINIUM RIVET 40APR1/8 (BOTH SIDES)

3. DRILL #30 AND COUNTERSINK FOR #30 FLUSH STAINLESS STEEL RIVET CCC-42 (BOTH SIDES) FORM RIVET, AFTER PULLING, TO BE FLUSH WITH TUBE

TRIM AS NEEDED BEFORE RIVETING TO OBTAIN 1/2" CLEARANCE

MD5158

**RRR S-19 VENTERRA**  
**FLAP RELEASE TUBE ASSEMBLY**  
**FIGURE 08B-08**

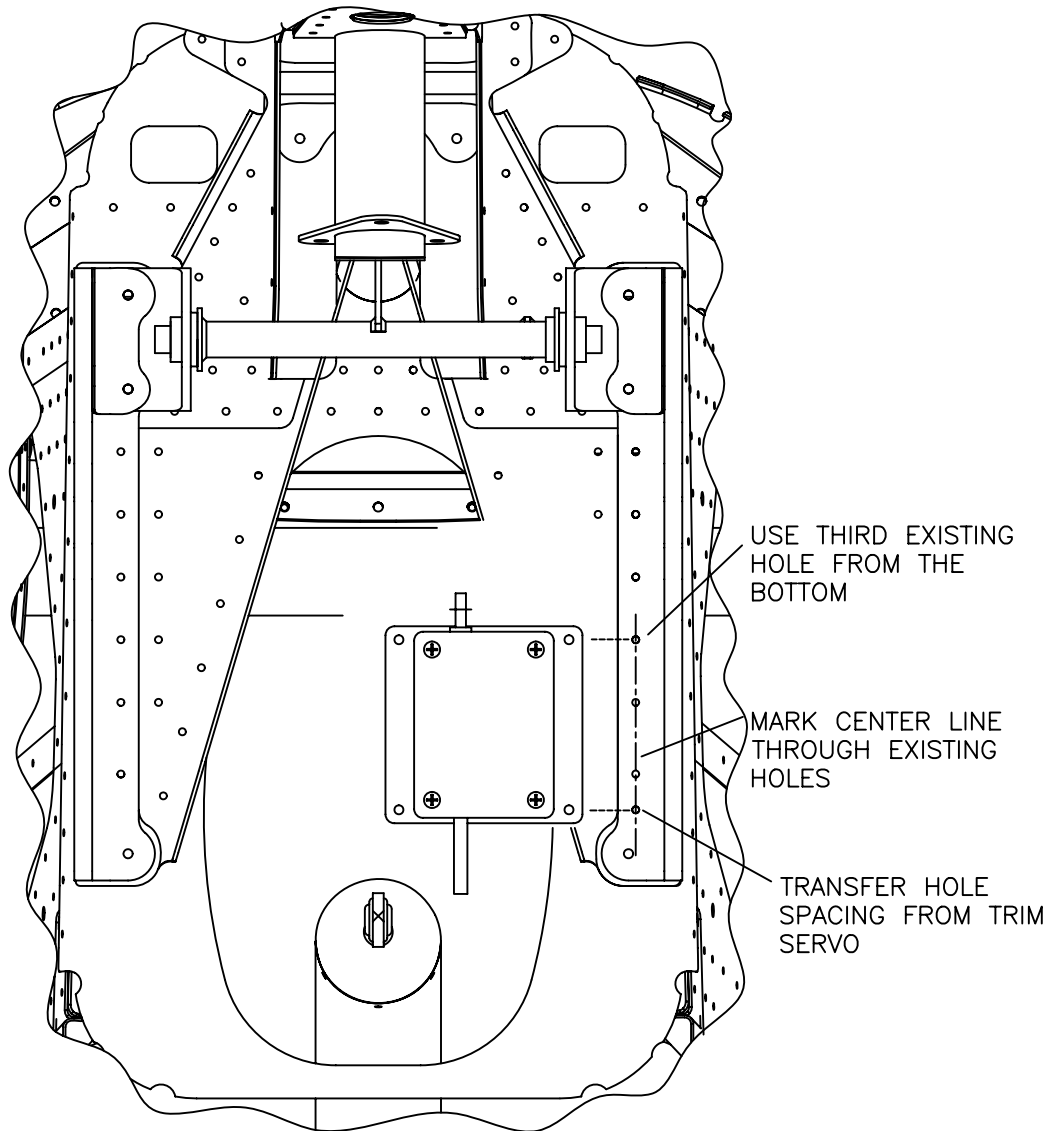

MD5219

**RANS S-19 VENTERRA**  
**TRIM SERVO ATTACH**  
**FIGURE 08C-02**

CAUTION:  
THREADS MUST BE ENGAGED  
A MINIMUM OF 10 FULL THREADS

ADJUST PUSH-PULL TUBE LENGTH SO  
ANTI-SERVO/TRIM TAB IS NEUTRAL WHEN  
SERVO, BELLCRANK, AND STABILATOR ARE IN  
NEUTRAL POSITION.

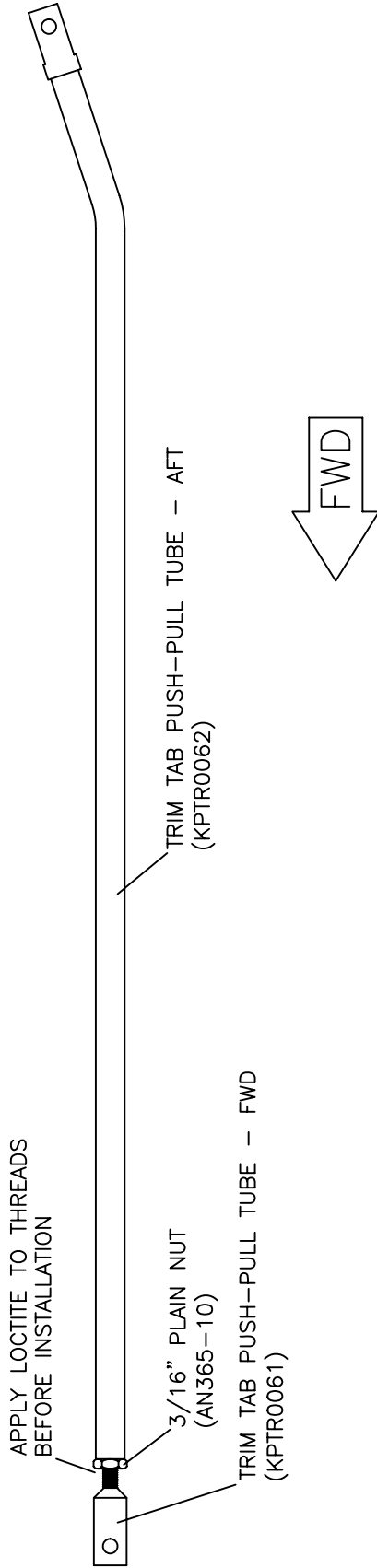

**RRR** S-19 VENTERRA  
TRIM TAB PUSH-PULL TUBE  
FIGURE 08C-10

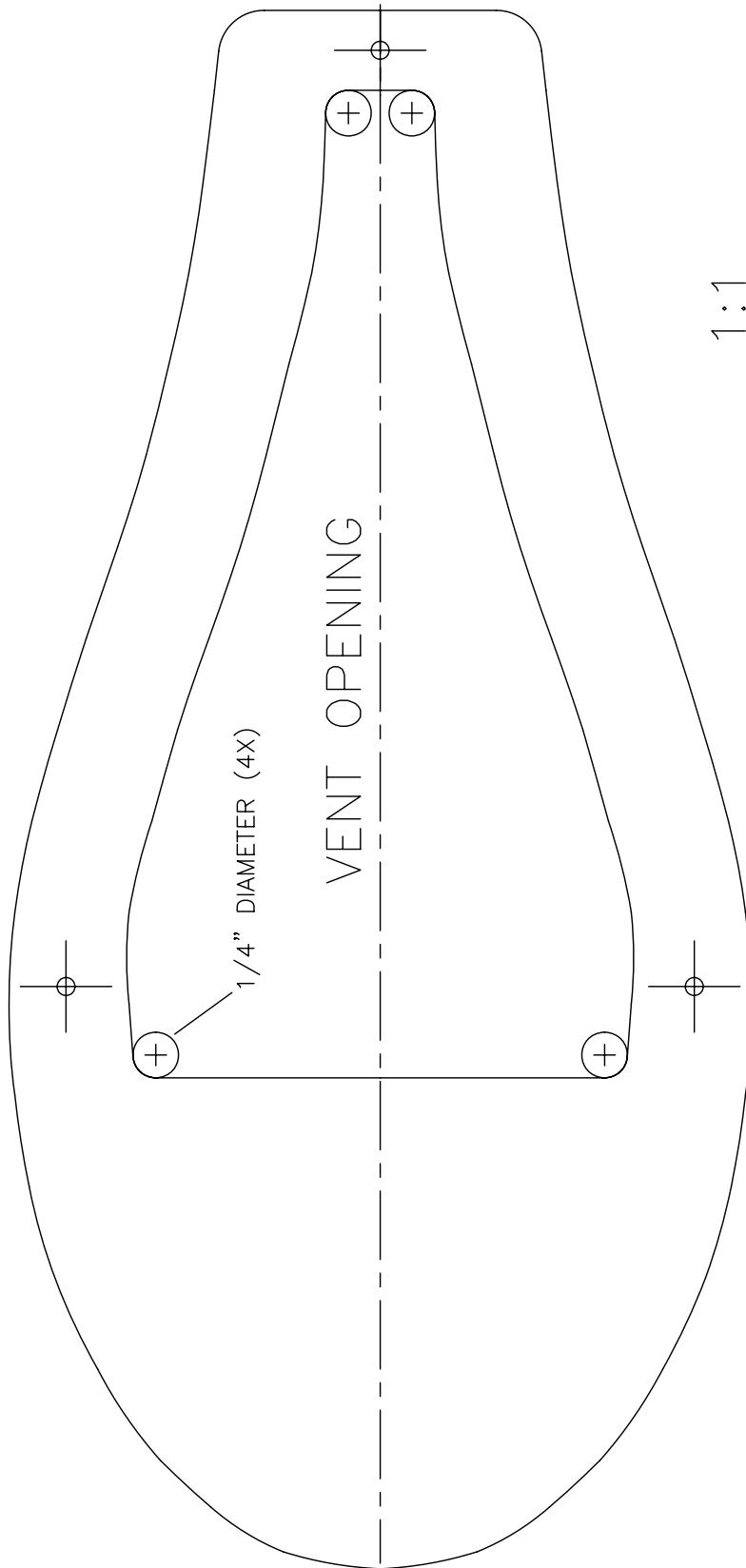

MD5449

**RAMMS S-19 VENTERRA**  
**OPTIONAL VENT TEMPLATE**  
**FIGURE 08D-02**

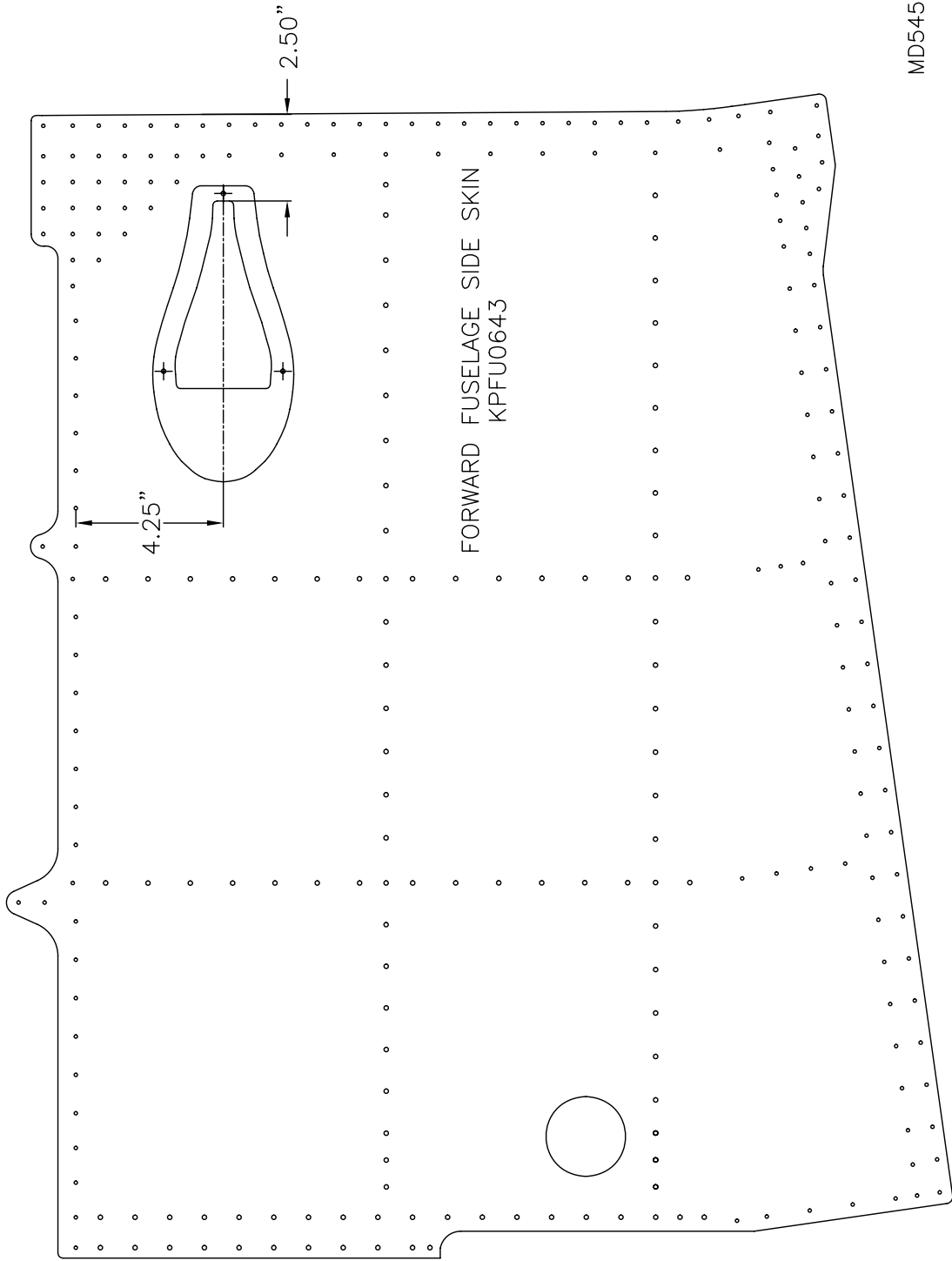

MD5450

**RRR S-19 VENTERRA**  
**OPTIONAL VENT TEMPLATE LOCATION**  
**FIGURE 08D-03**

## 09 – MAIN & NOSE GEAR

LANDING GEAR INSTALLATION .....	09-06
LANDING GEAR INSTALLATION .....	09-09
LANDING GEAR INSTALLATION .....	09-09A
NOSE GEAR INSTALLATION.....	09B-05
NOSE GEAR ALIGNMENT .....	09B-07
SPRING WASHER MODIFICATION .....	09B-15
NOSE GEAR/FORK INSTALLATION.....	09B-16
FORK TENSION ADJUSTMENT.....	09B-17
NOSE WHEEL SPACER BUSHING MODIFICATION .....	09B-20
MAIN GEAR AXLE MODIFICATION .....	09C-03
MAIN WHEEL PANT SPACER BLOCK.....	09C-07
MAIN WHEEL PANT CLEARANCE .....	09C-07A
MAIN WHEEL PANT LEVELING.....	09C-08
MAIN WHEEL PANT SQUARING .....	09C-09
MAIN WHEEL PANT MODIFICATION .....	09C-10
MAIN WHEEL PANT – INNER BRACKET HOLE LOCATION.....	09C-17
MAIN WHEEL PANT DRILLING.....	09C-18
WHEEL PANT MODIFICATION .....	09C-20
NOSE GEAR TOW PLATE MODIFICATION.....	09D-03
NOSE WHEEL PANT TRIMMING .....	09D-04
NOSE WHEEL PANT TRIMMING .....	09D-07
NOSE WHEEL PANT DRILLING.....	09D-09
BELLY FAIRING MODIFICATION.....	09E-04
NOSE GEAR TOW PLATE MODIFICATION.....	09F-02



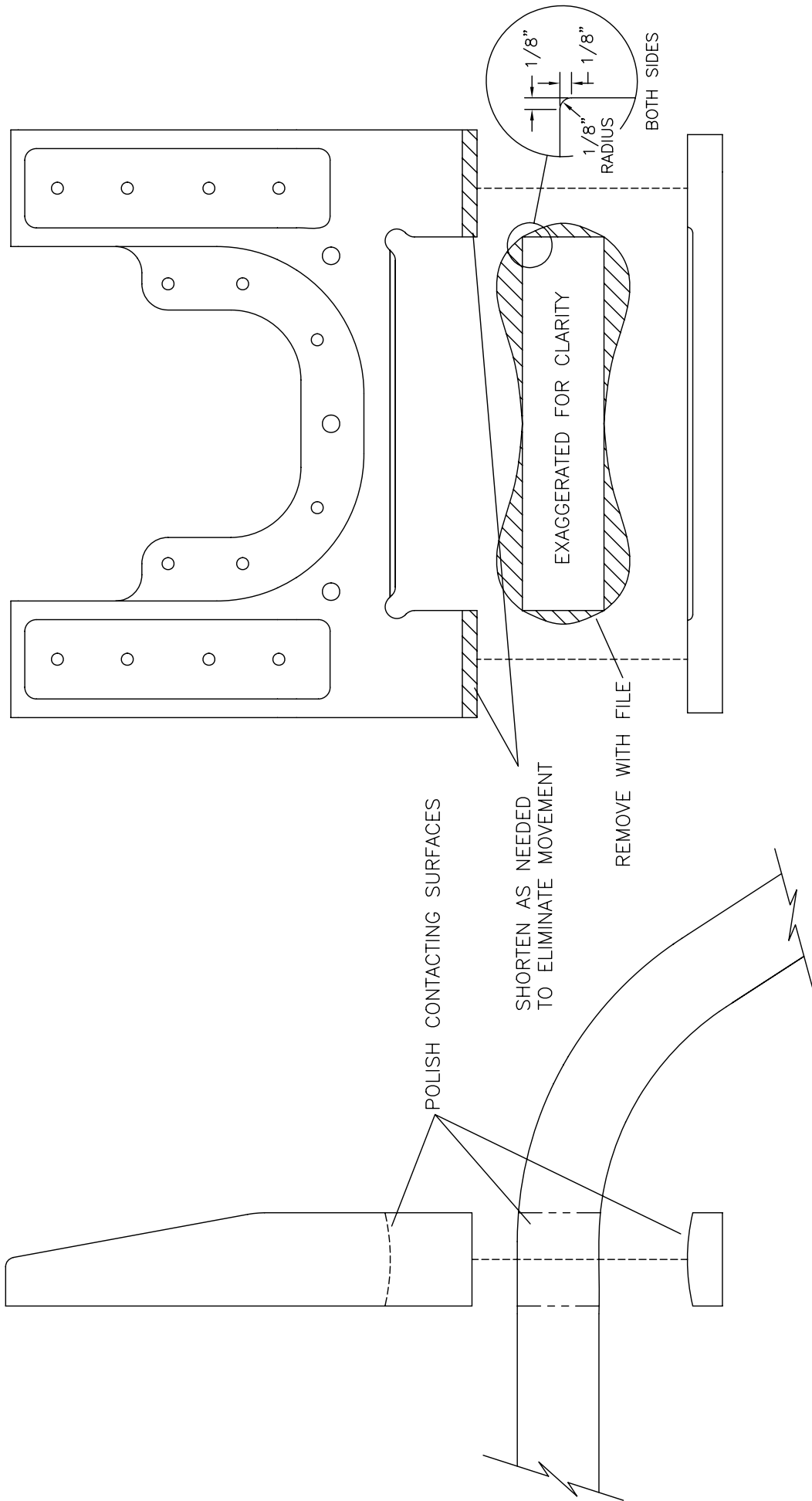

MD5076

**RAMS S-19 VENTERRA**  
**LANDING GEAR INSTALLATION**  
**FIGURE 09-06**

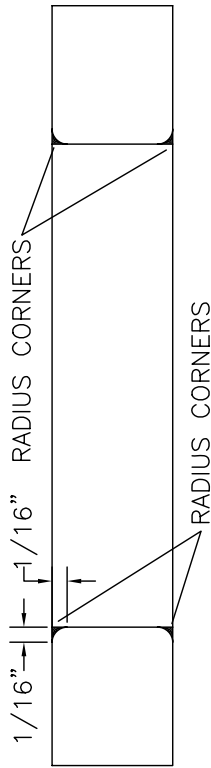
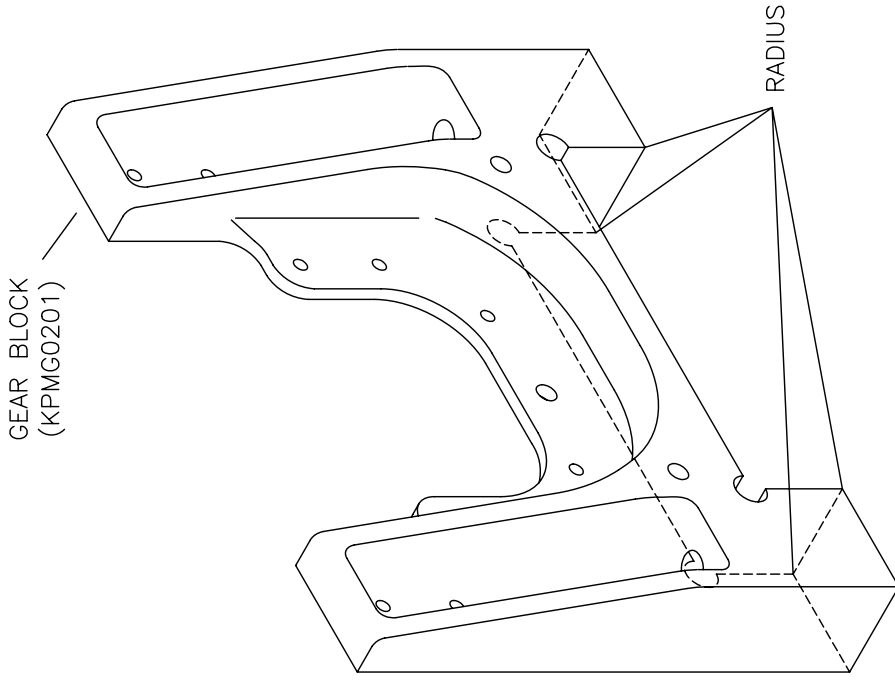

BOTTOM VIEW  
(RADIi EXAGGERATED FOR CLARITY)

MD5075

**RRR S-19 VENTERRA**  
**LANDING GEAR INSTALLATION**  
**FIGURE 09-09**

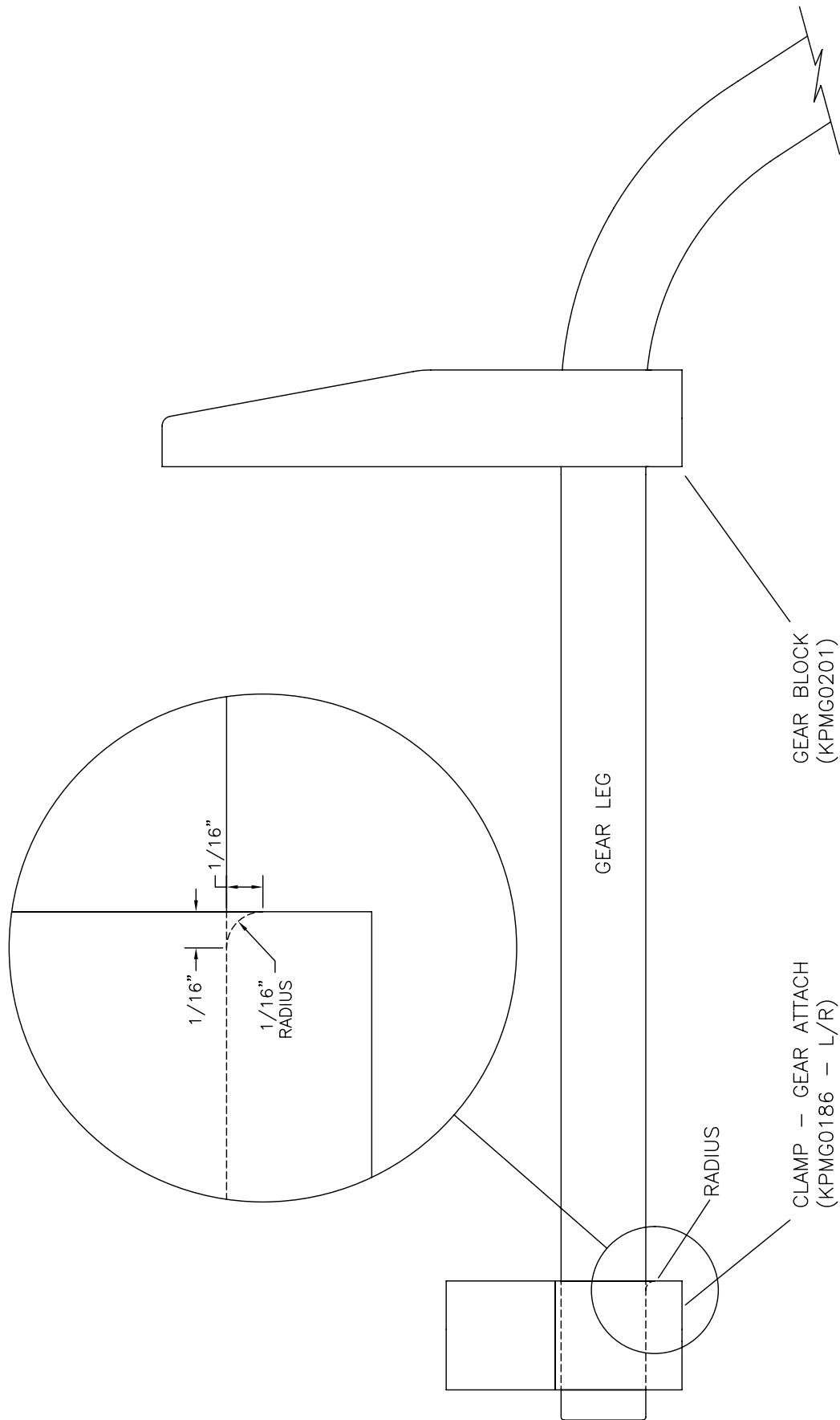

MD5077

**RRR** S-19 VENTERRA  
 LANDING GEAR INSTALLATION  
 FIGURE 09-09A

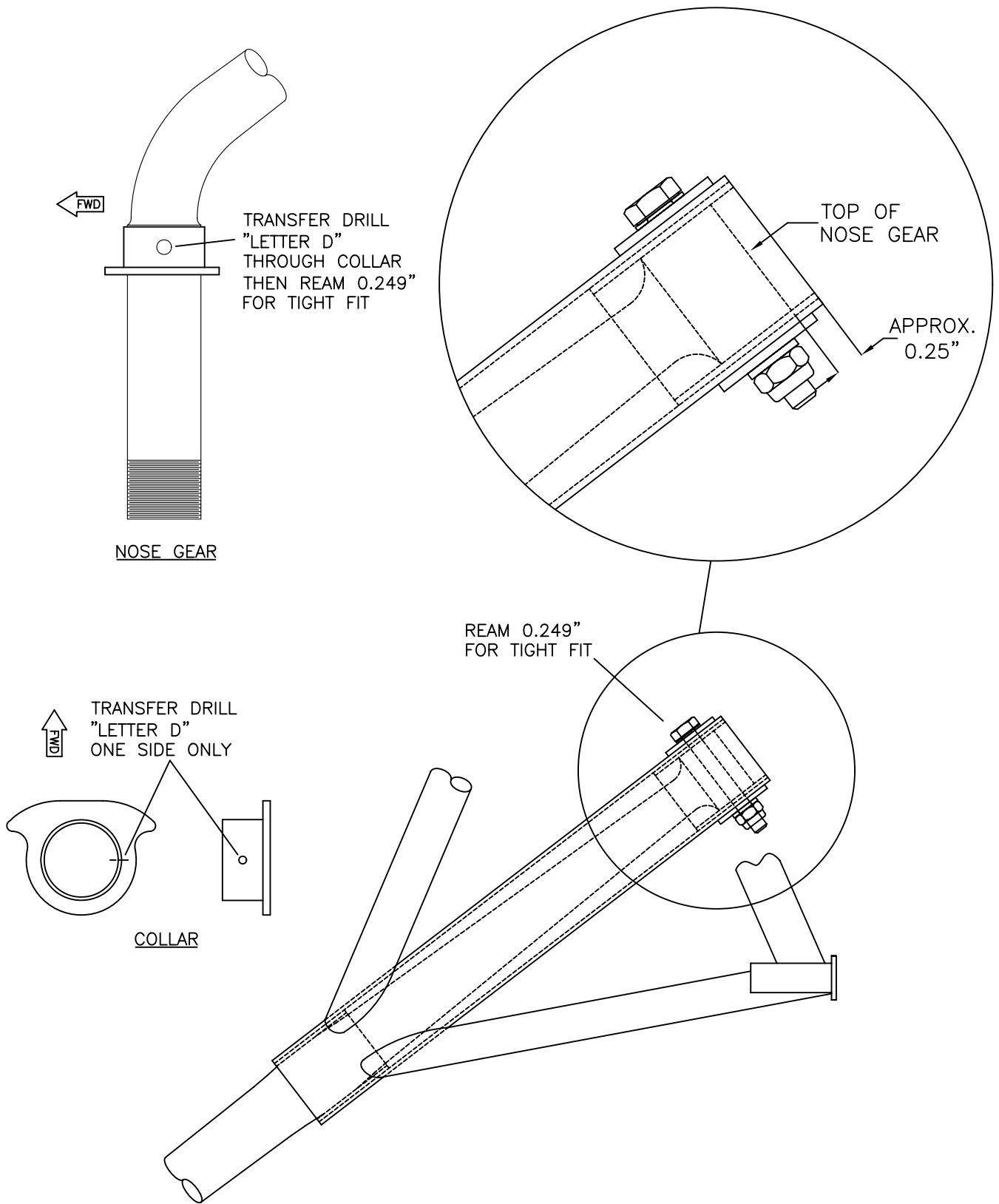

MD5112

**RANS S-19**  
**NOSE GEAR INSTALLATION**  
**FIGURE 09B-05**

04/01/2011

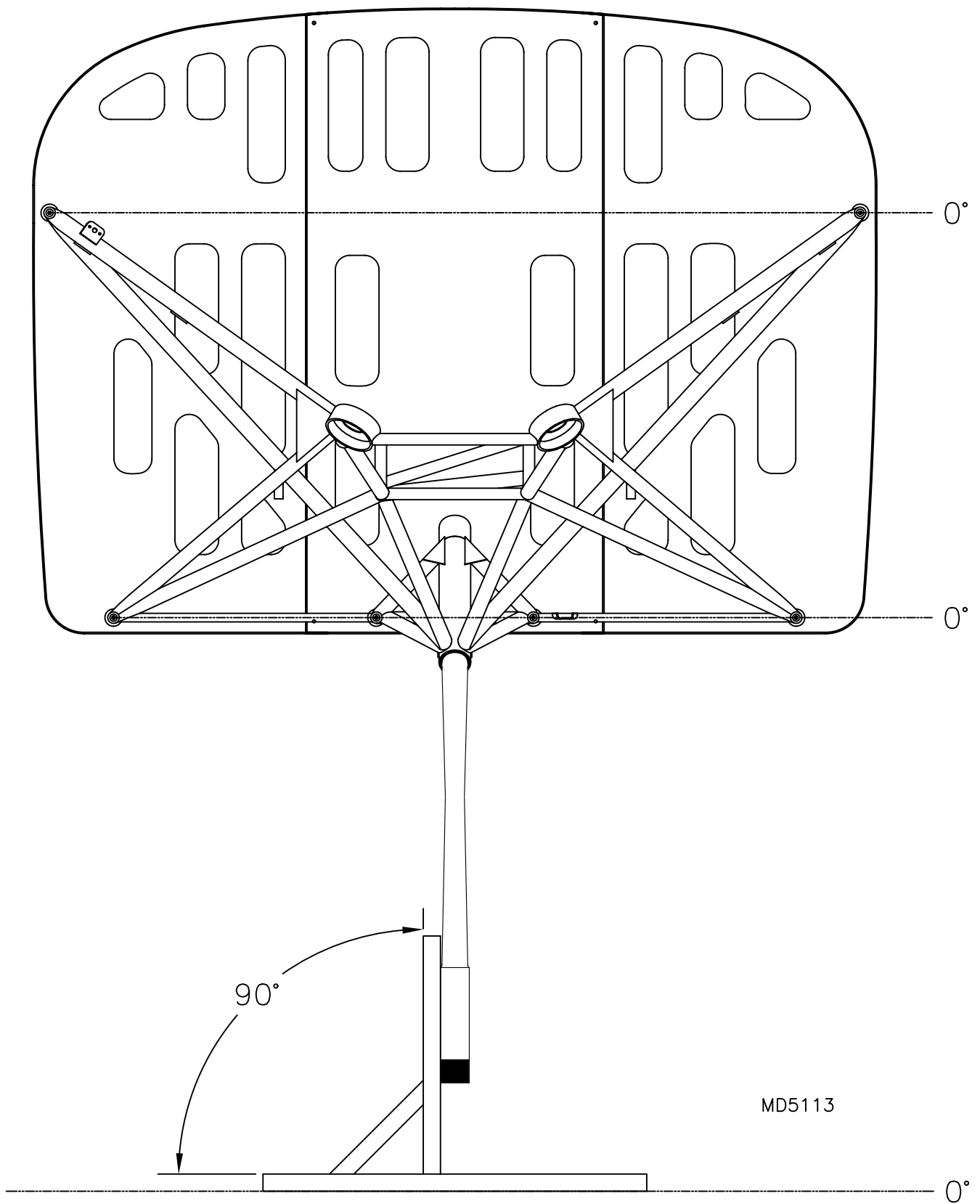

RANS S-19 VENTERRA  
 NOSE GEAR ALIGNMENT  
 FIGURE 09B-07

04/01/2011

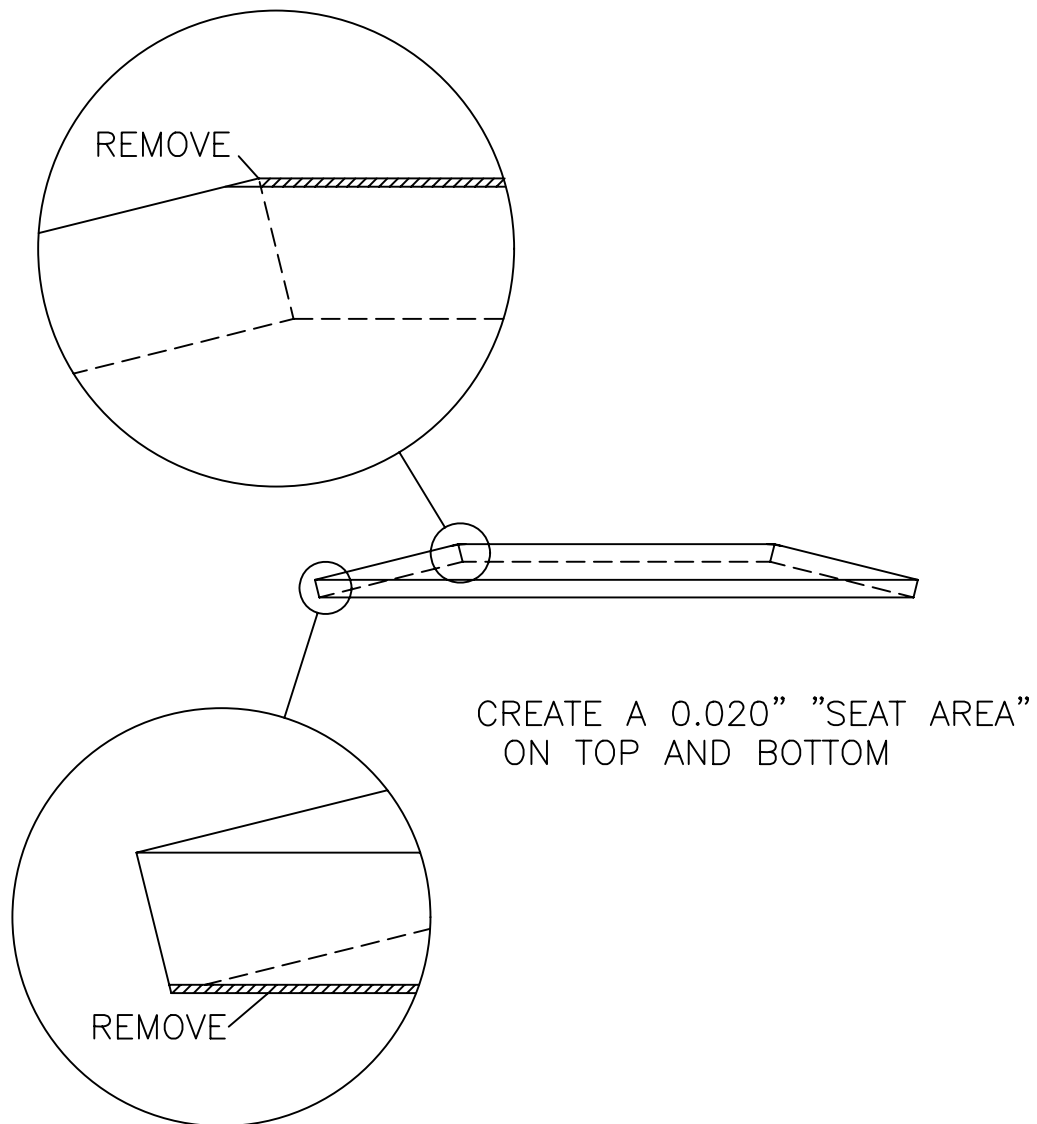

**RANS S-19 VENTERRA**  
**SPRING WASHER MODIFICATION**  
**FIGURE 09B-15**

MD5220

04/01/2011

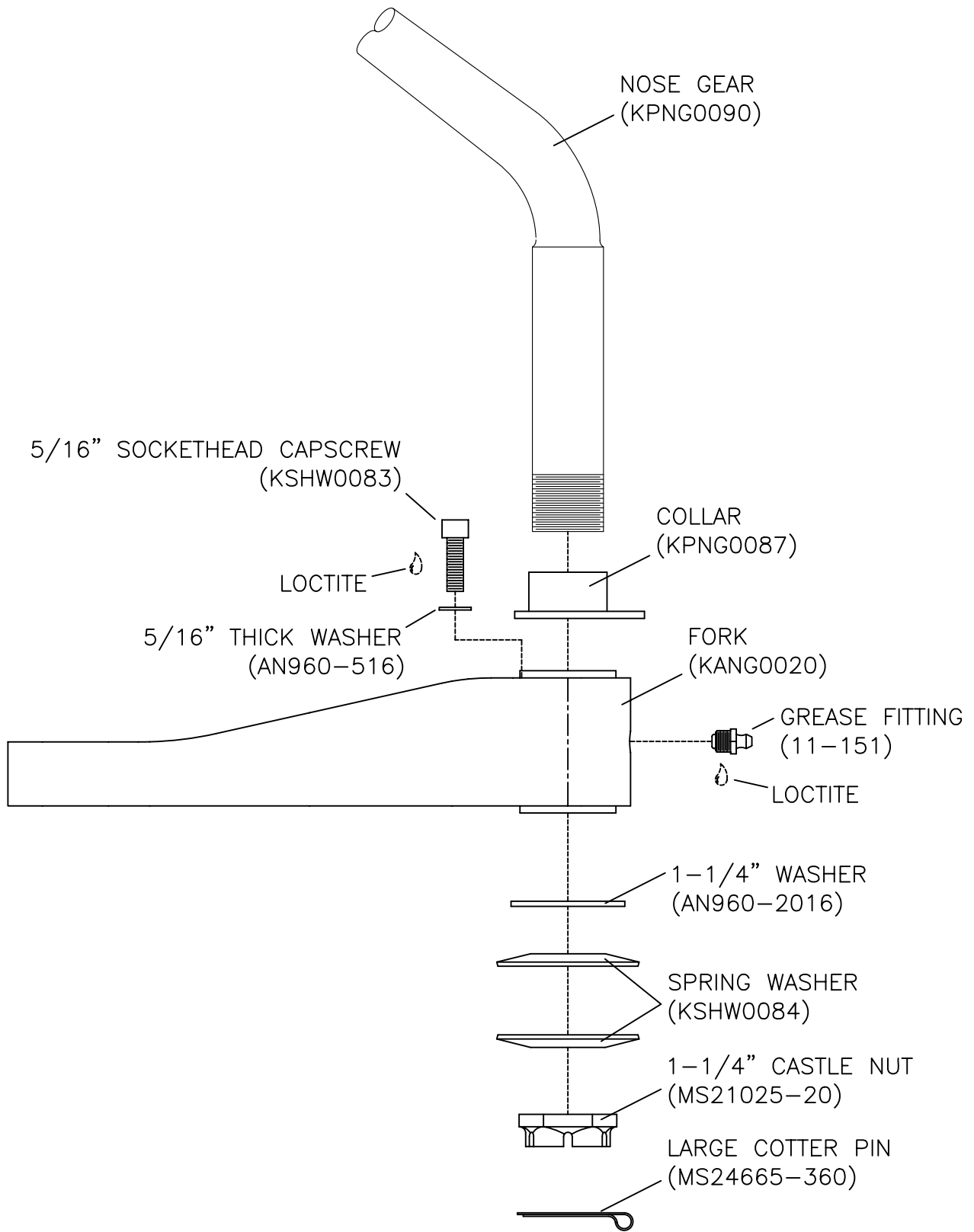

MD5086

**RAMS S-19 VENTERRA**  
**NOSE GEAR/FORK INSTALLATION**  
**FIGURE 09B-16**

04/01/2011

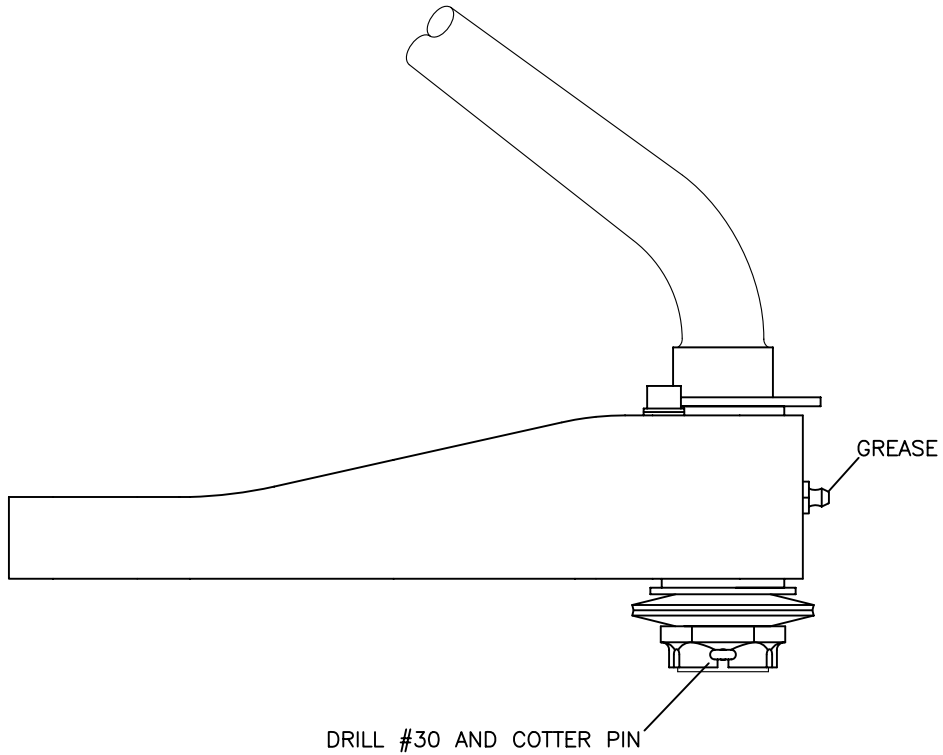
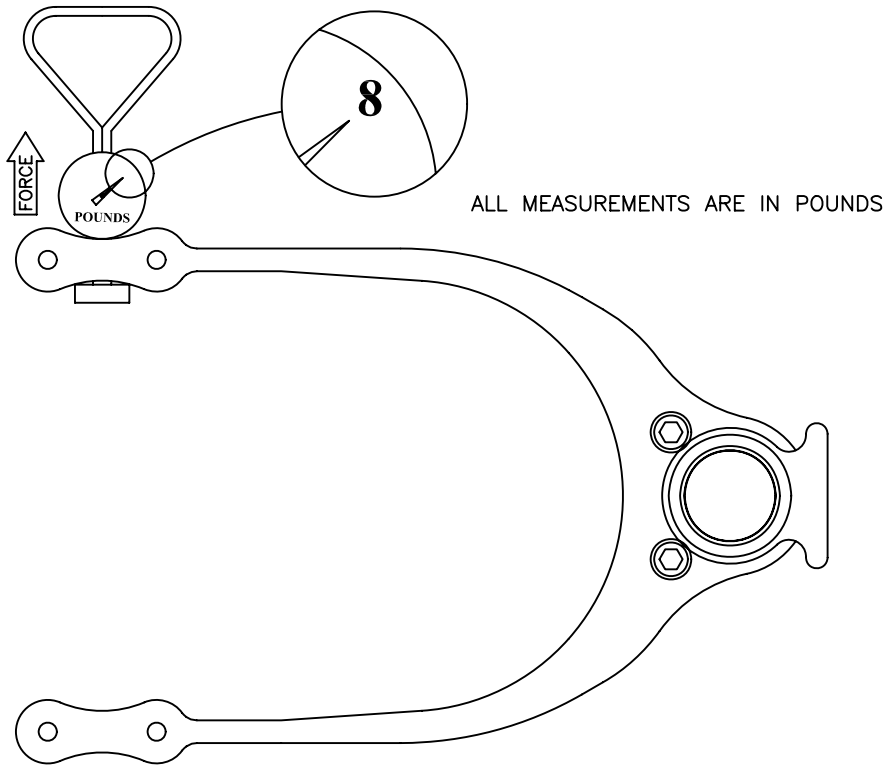

MD5111

**RANS S-19 VENTERRA**  
**FORK TENSION ADJUSTMENT**  
**FIGURE 09B-17**

04/01/2011



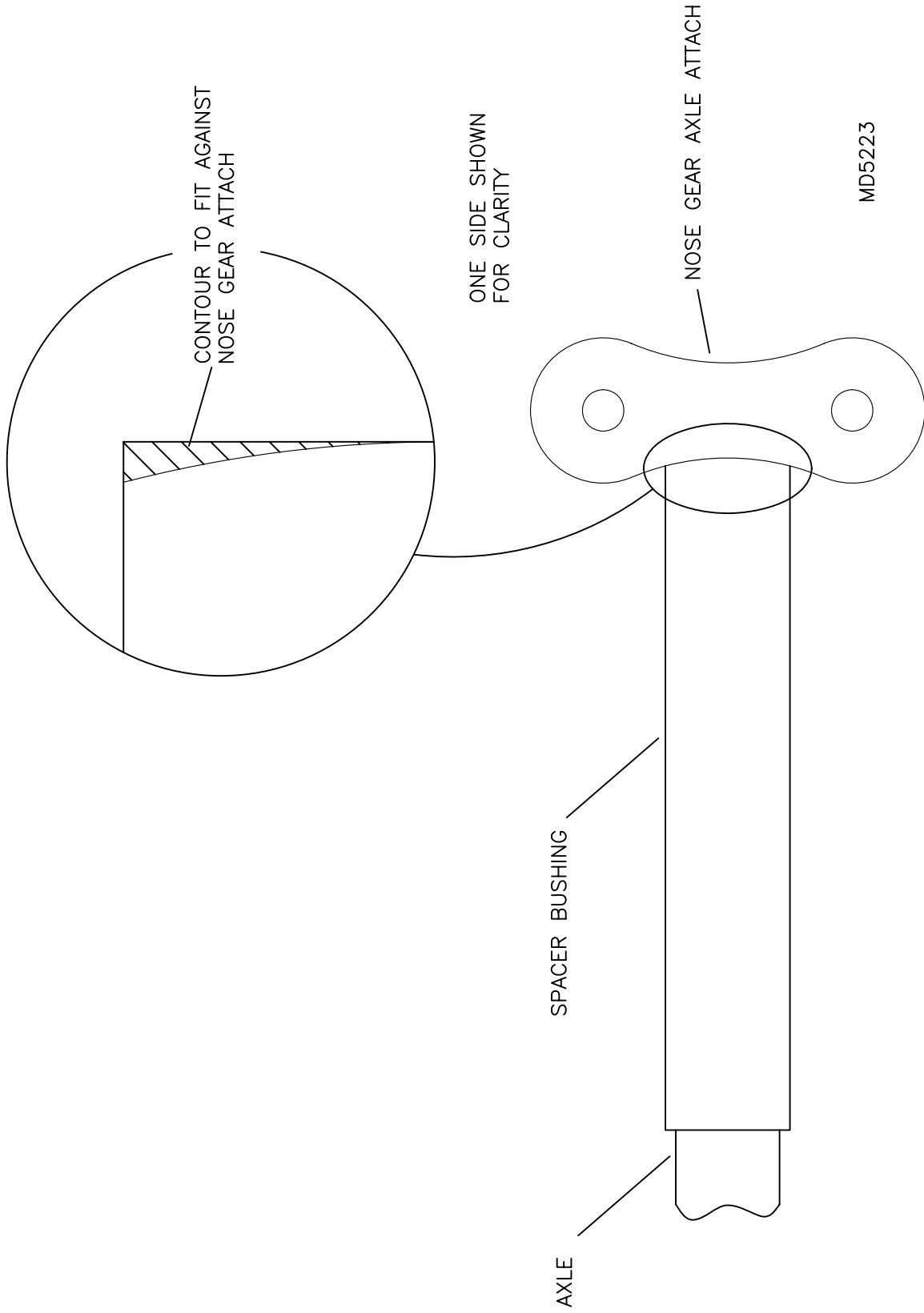

**RRANOS S-19 VENTERRA**  
**NOSE WHEEL SPACER BUSHING MODIFICATION**  
**FIGURE 09B-20**

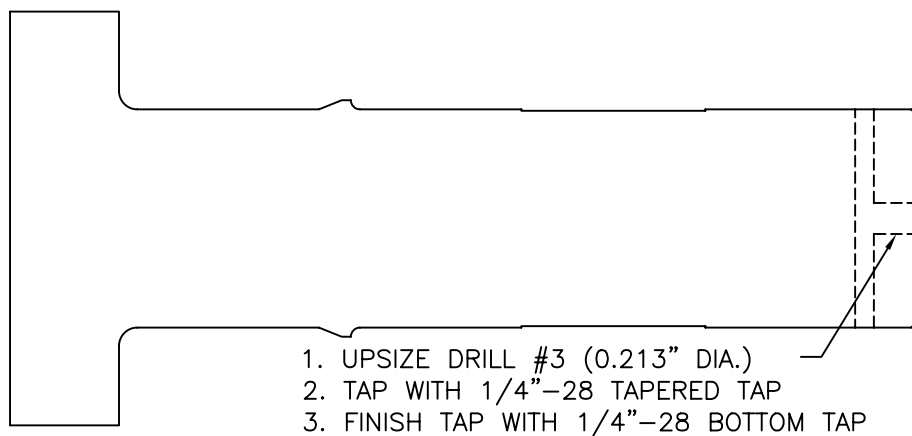
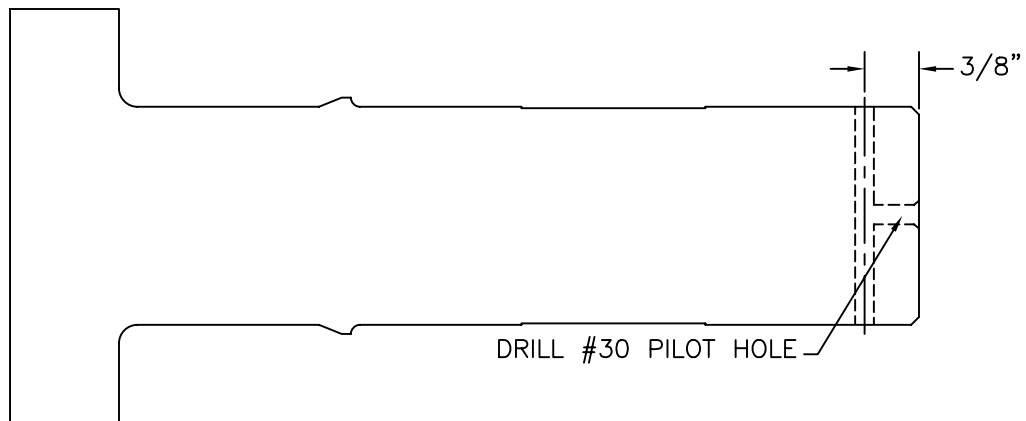
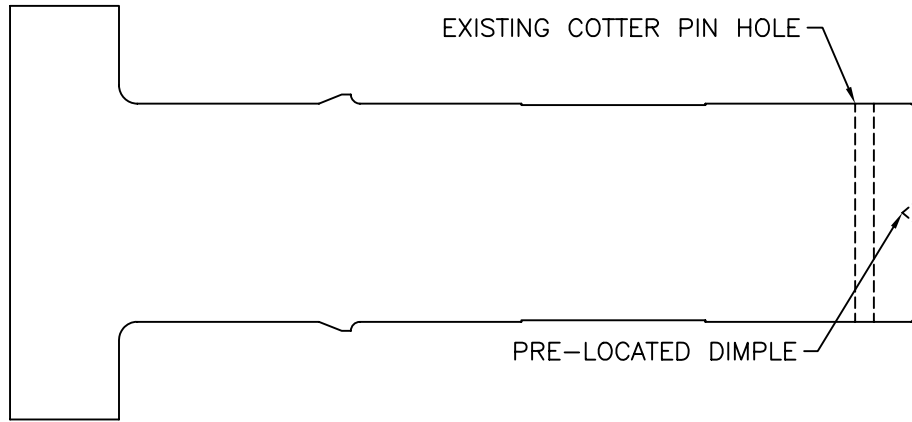

MD5489

**RANDS S-19 VENTERRA**  
**MAIN GEAR AXLE MODIFICATION**  
**FIGURE 09C-03**

04/01/2011

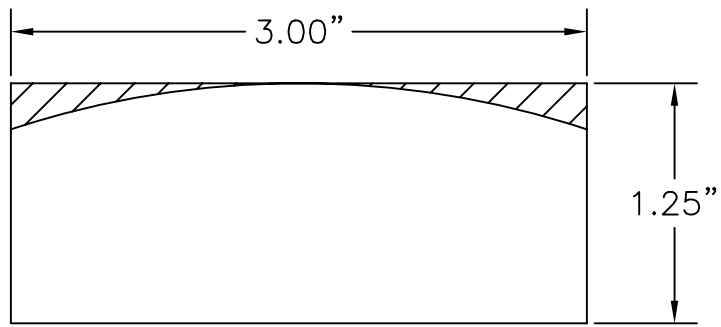

SIDE

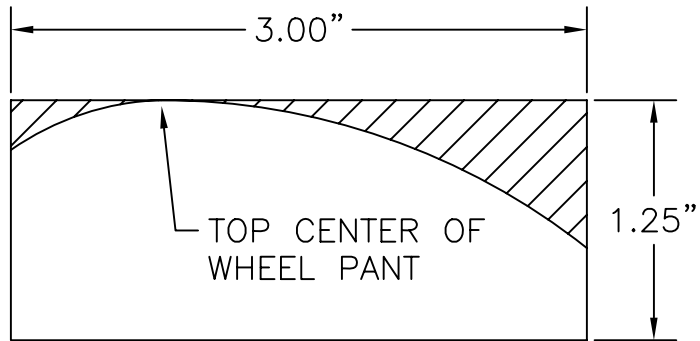

FRONT

PROFILE BLOCK TO MATCH  
WHEEL PANT PROFILE

MD5488

**RANS S-19 VENTERRA**  
**MAIN WHEEL PANT SPACER BLOCK**  
**FIGURE 09C-07**

04/01/2011

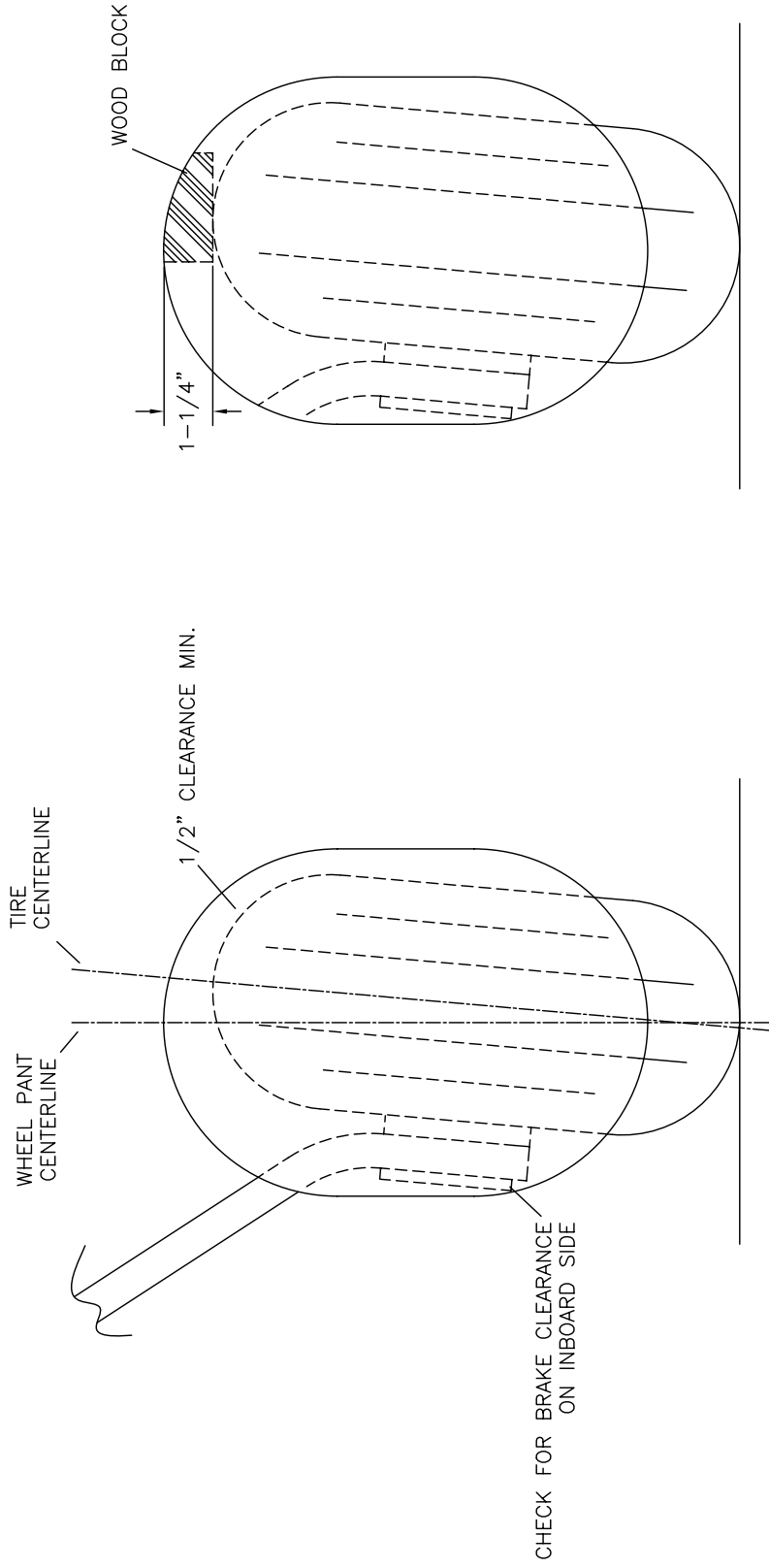

MD5493

**RRRAMES S-19 VENTERRA**  
**MAIN WHEEL PANT CLEARANCE**  
**FIGURE 09C-07A**

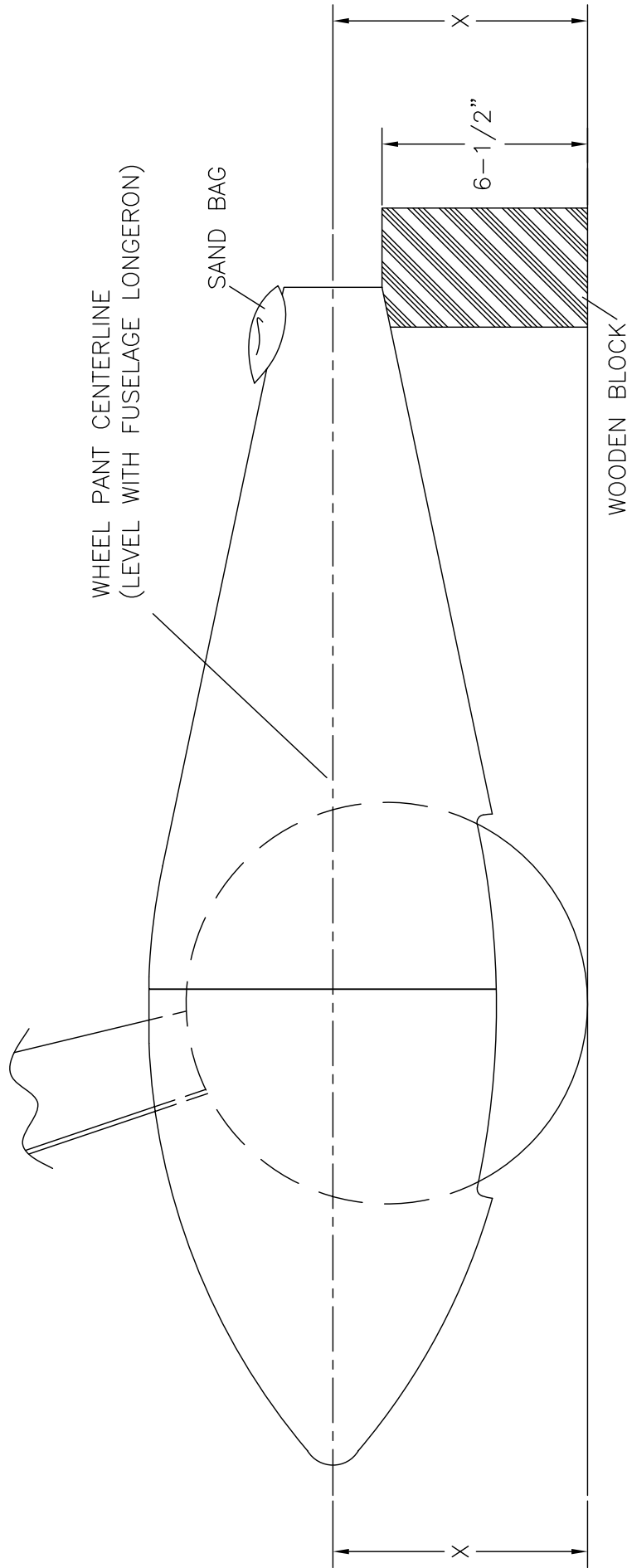

X = SAME DROP DOWN MEASUREMENTS

MD5492

**RRAMES S-19 VENTERRA**  
**MAIN WHEEL PANT LEVELING**  
**FIGURE 09C-08**

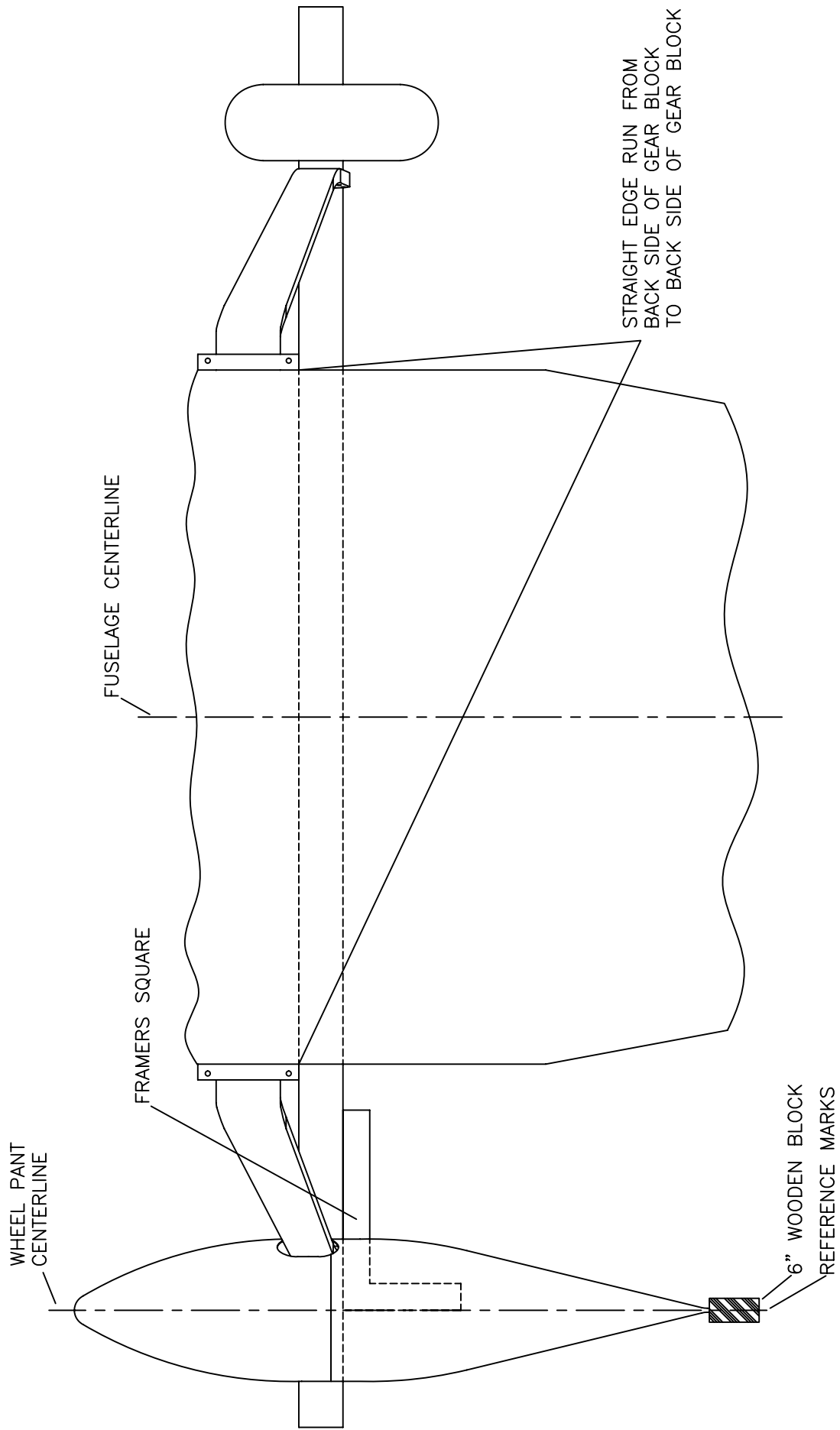

STRAIGHT EDGE RUN FROM  
BACK SIDE OF GEAR BLOCK  
TO BACK SIDE OF GEAR BLOCK

MD5491

**RAMS S-19 VENTERRA**  
**MAIN WHEEL PANT SQUARING**  
**FIGURE 09C-09**

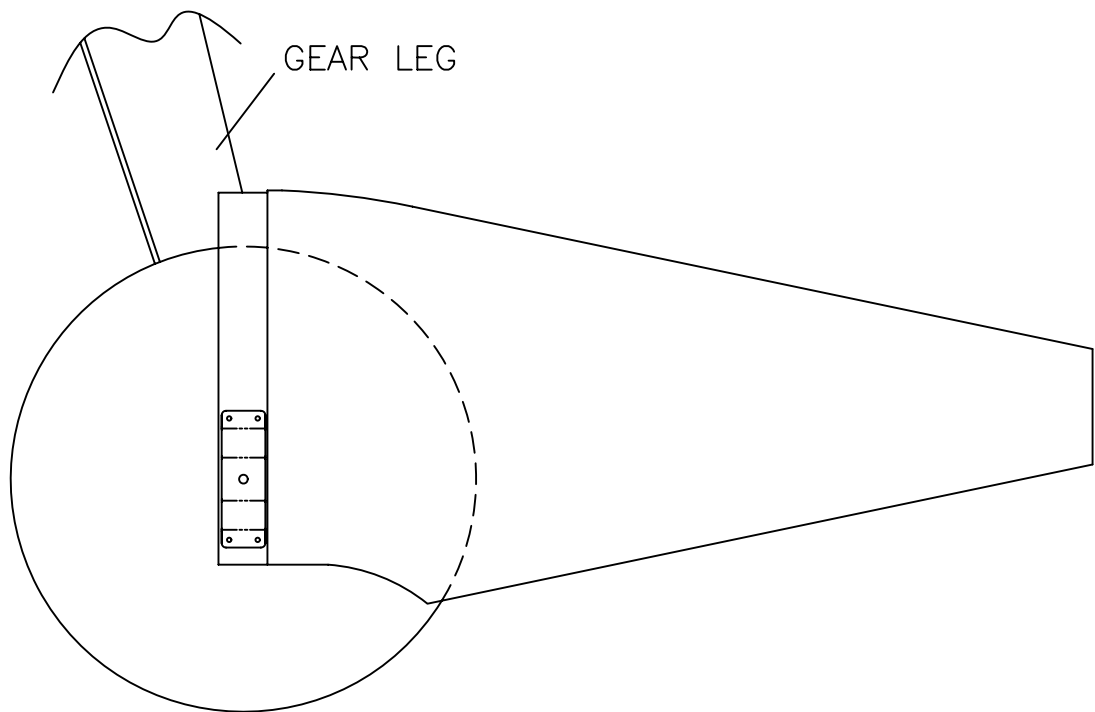
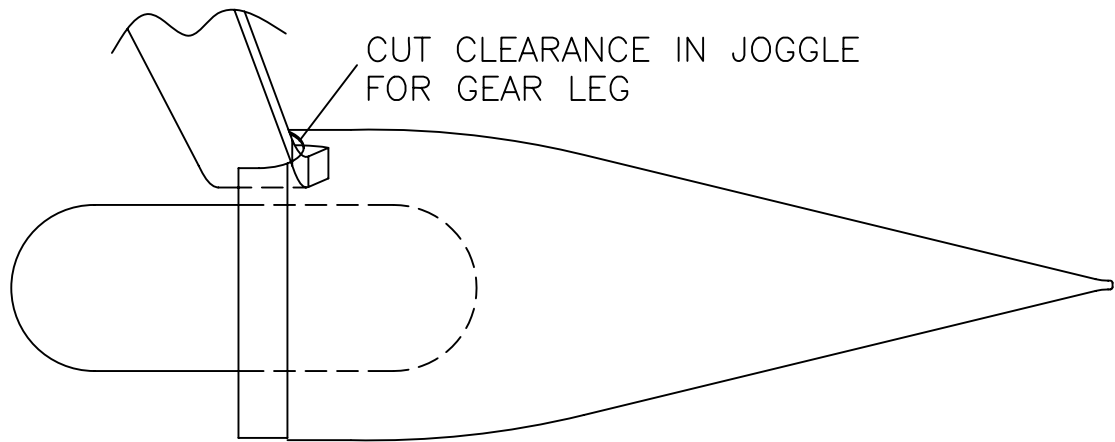

MD5490

**RANS S-19 VENTERRA**  
**MAIN WHEEL PANT MODIFICATION**  
**FIGURE 09C-10**

04/01/2011

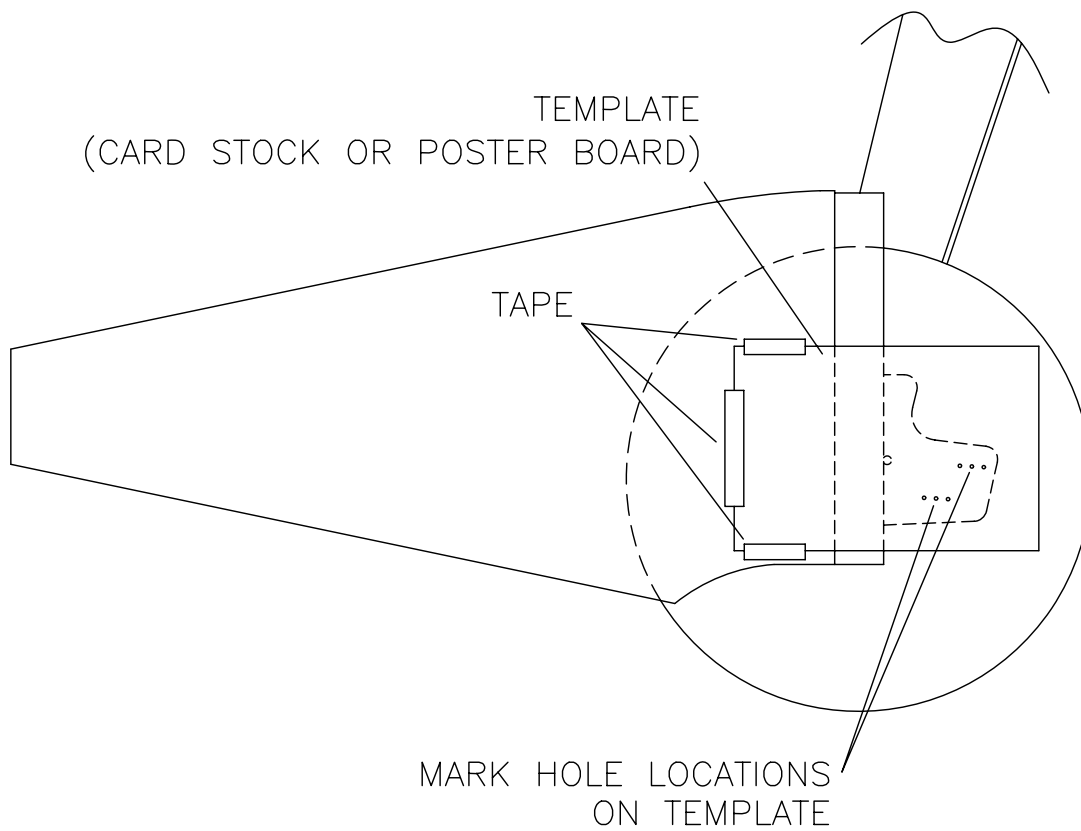

**RANS S-19 VENTERRA**  
**MAIN WHEEL PANT**  
**INNER BRACKET HOLE LOCATION**  
**FIGURE 09C-17**

MD5494

04/01/2011



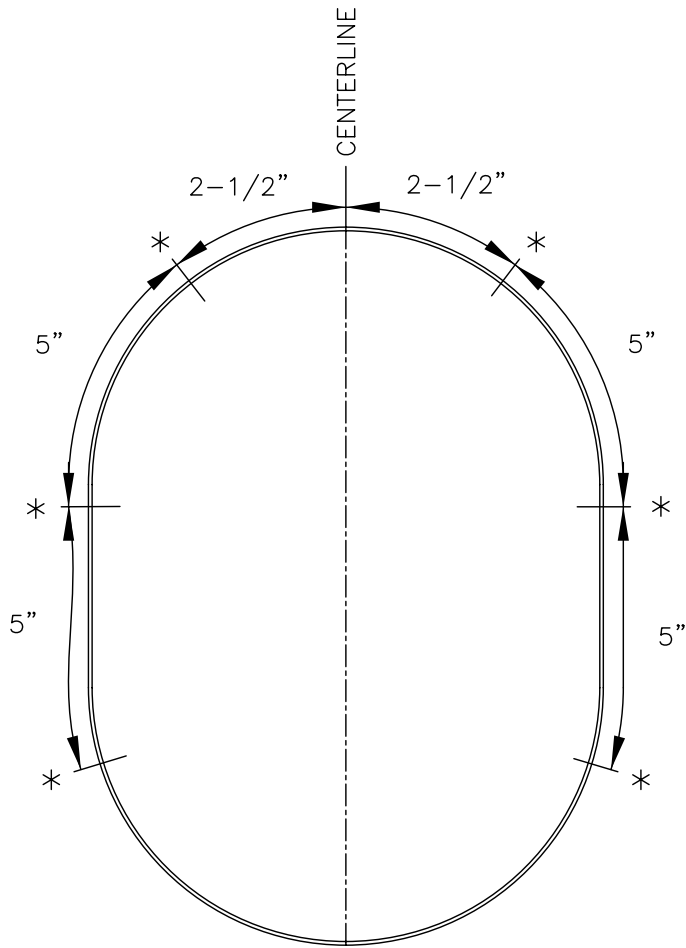

\* DRILL THROUGH AT THESE 6 LOCATIONS

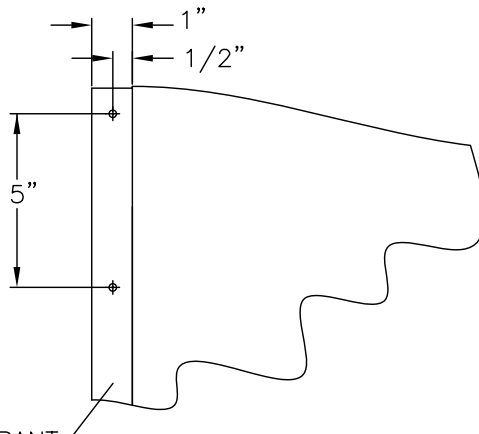

JOGGLE ON AFT WHEEL PANT

**RANS S-19 VENTERRA**  
**MAIN WHEEL PANT DRILLING**  
**FIGURE 09C-18**

MD4897

04/01/2011

CENTER ON  
AFT WHEEL PANT  
ATTACH HOLES.  
CUT AS SHOWN

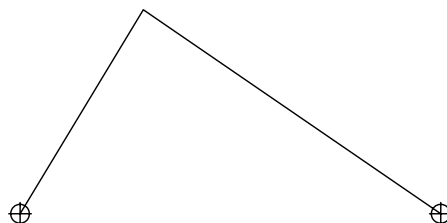

DRILL 1/4"  
EACH CORNER

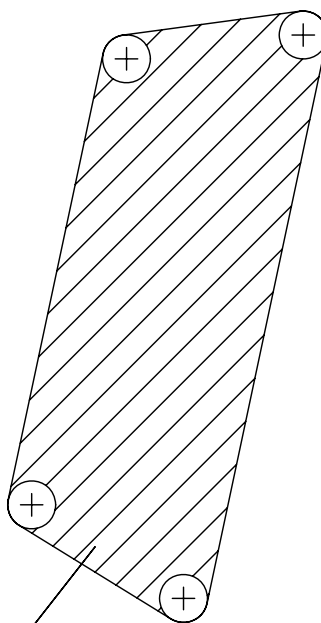

USE DREMEL  
TO CUT OUT MATERIAL

1:1 TEMPLATE

MD5514

**RAMS S-19 VENTERRA**  
**WHEEL PANT MODIFICATION**  
**FIGURE 09C-20**

04/01/2011

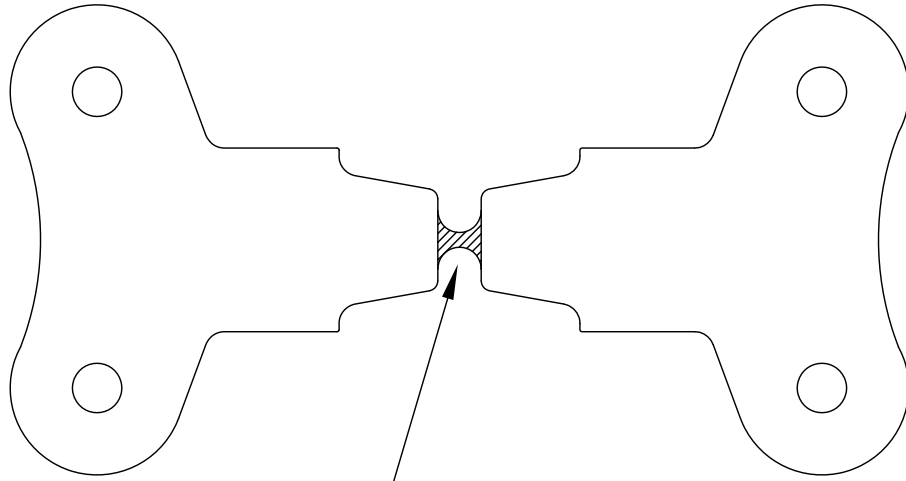

REMOVE THIS AREA  
TO MAKE 2 PARTS

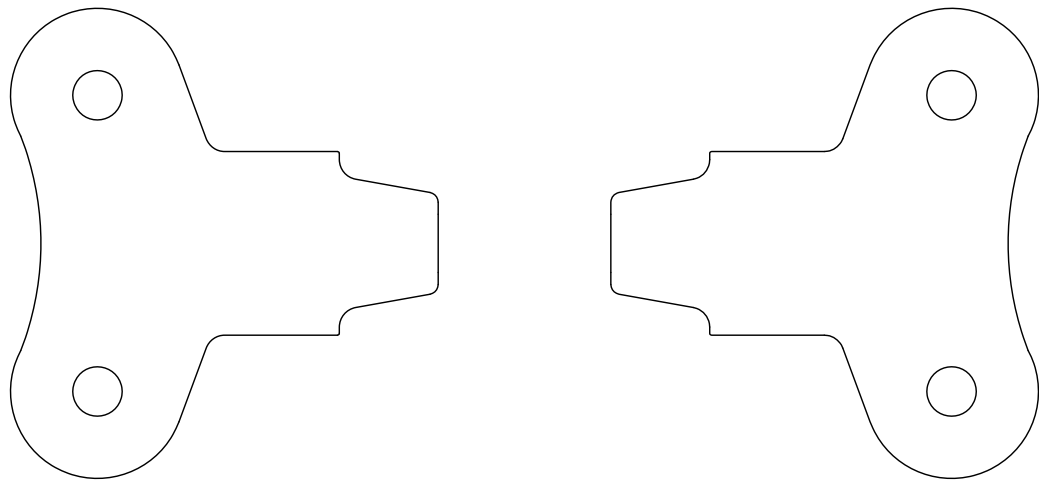

MD5497

**RAMS S-19 VENTERRA**  
**NOSE GEAR TOW PLATE MODIFICATION**  
**FIGURE 09D-03**

04/27/2017

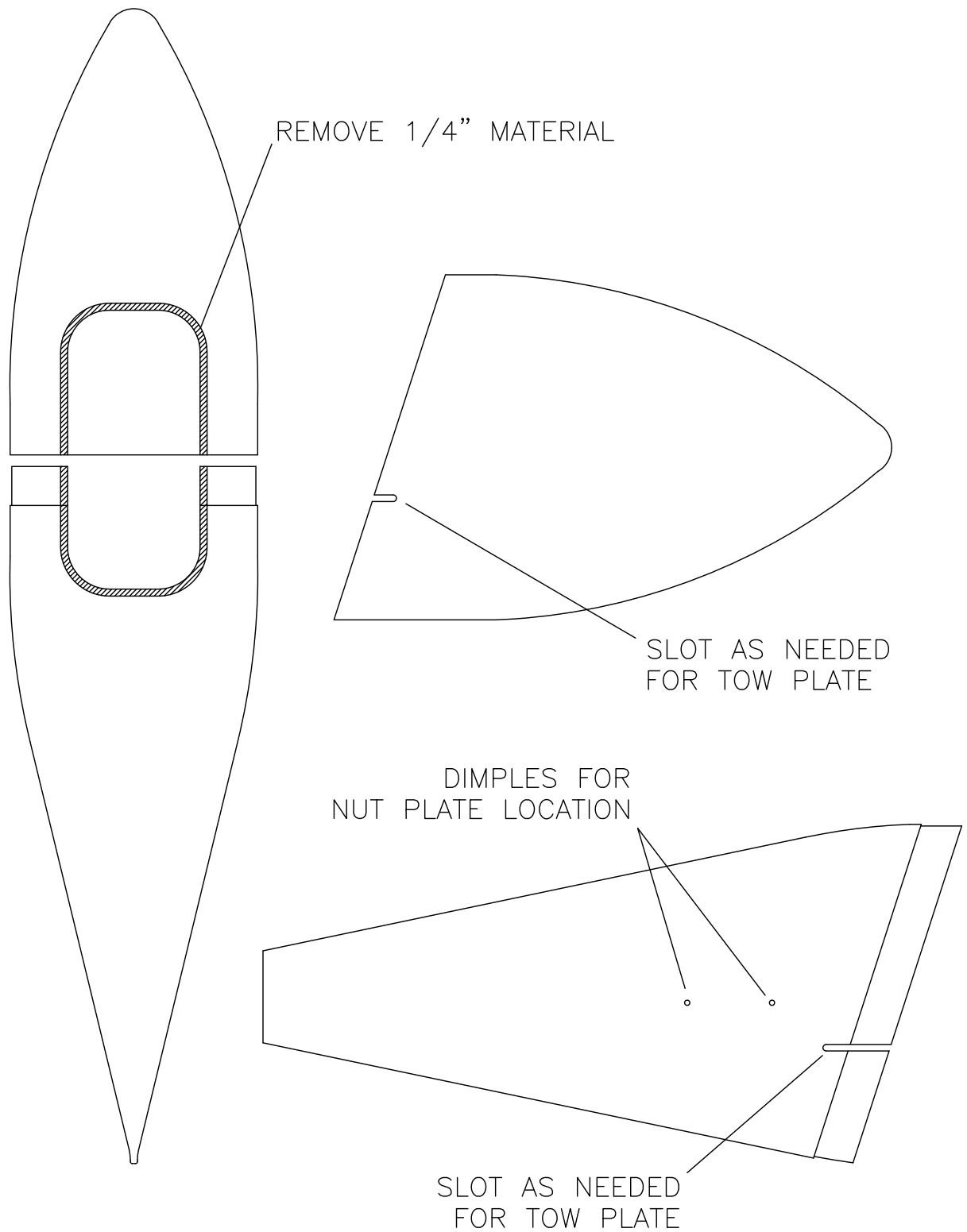

MD5495

**RANS S-19 VENTERRA**  
**NOSE WHEEL PANT TRIMMING**  
**FIGURE 09D-04**

04/01/2011

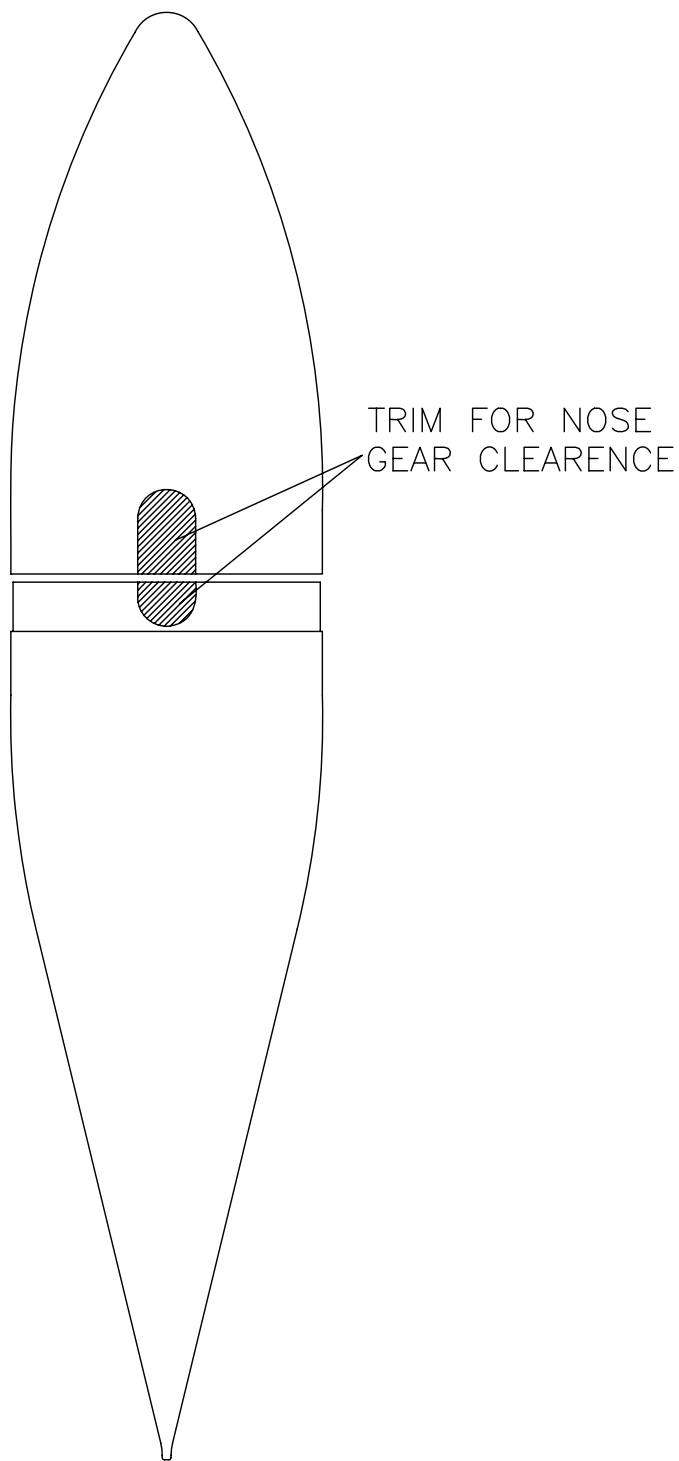

MD5496

**RANS S-19 VENTERRA**  
**NOSE WHEEL PANT TRIMMING**  
**FIGURE 09D-07**

04/01/2011

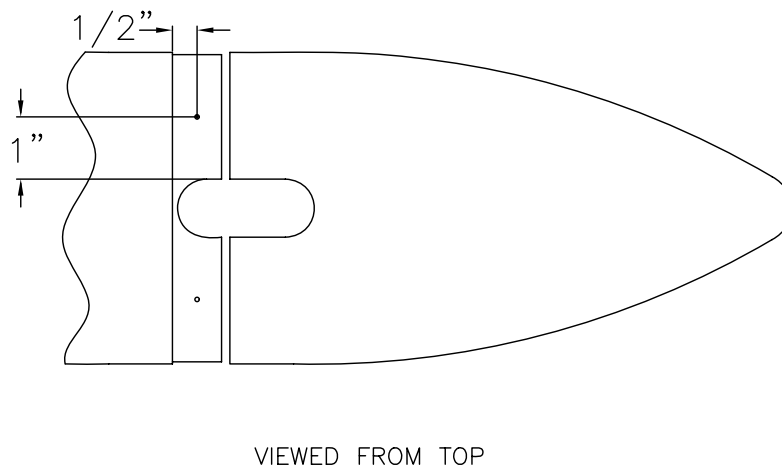
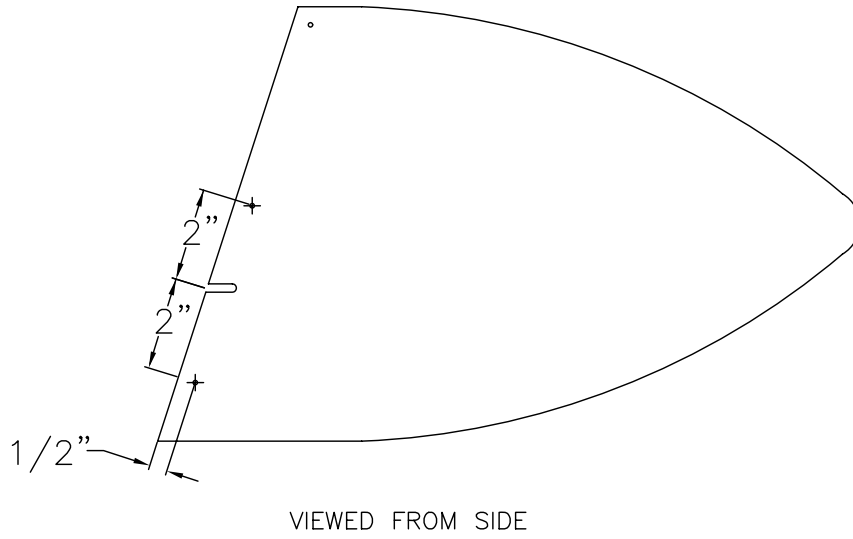

**RANDS S-19 VENTERRA**  
**NOSE WHEEL PANT DRILLING**  
**FIGURE 09D-09**

MD5497

04/01/2011

\* APPLY FOAM TO FUSELAGE ABOVE THIS EDGE

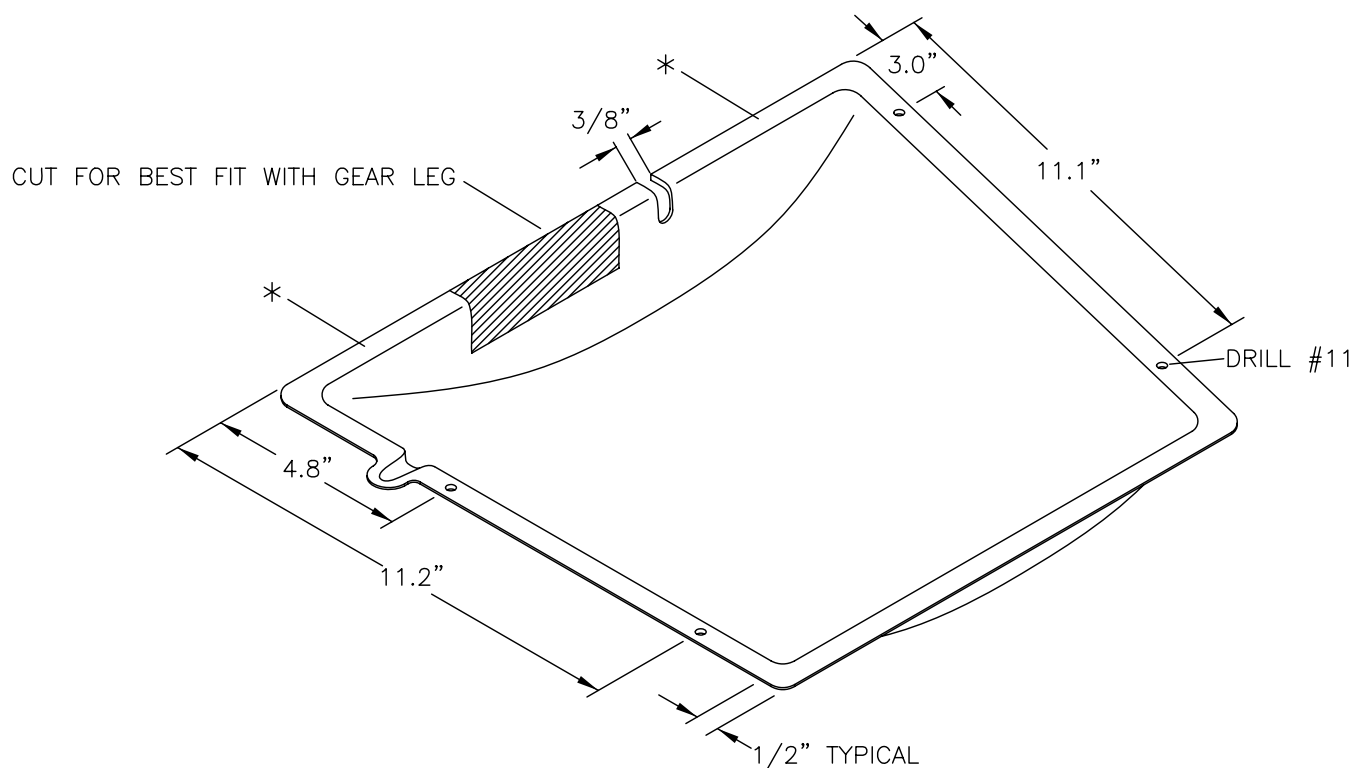

NOTE:  
DIMENSIONS ARE FOR REFERENCE ONLY.  
LOCATE HOLES AS NECESSARY TO MISS  
FUSELAGE RIBS AND INTERNAL  
SUPERSTRUCTURE.

**RANS S-19 VENTERRA**  
**BELLY FAIRING MODIFICATION**  
**FIGURE 09E-04**

MD5482

04/01/2011

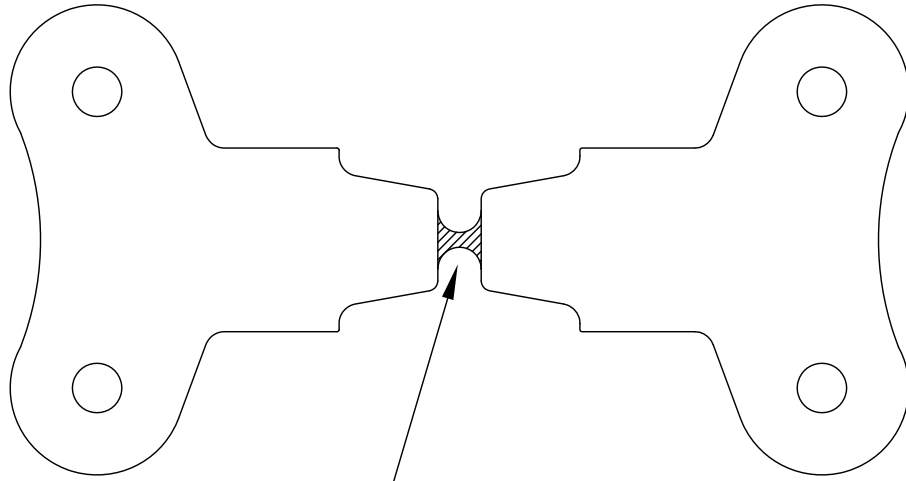

REMOVE THIS AREA  
TO MAKE 2 PARTS

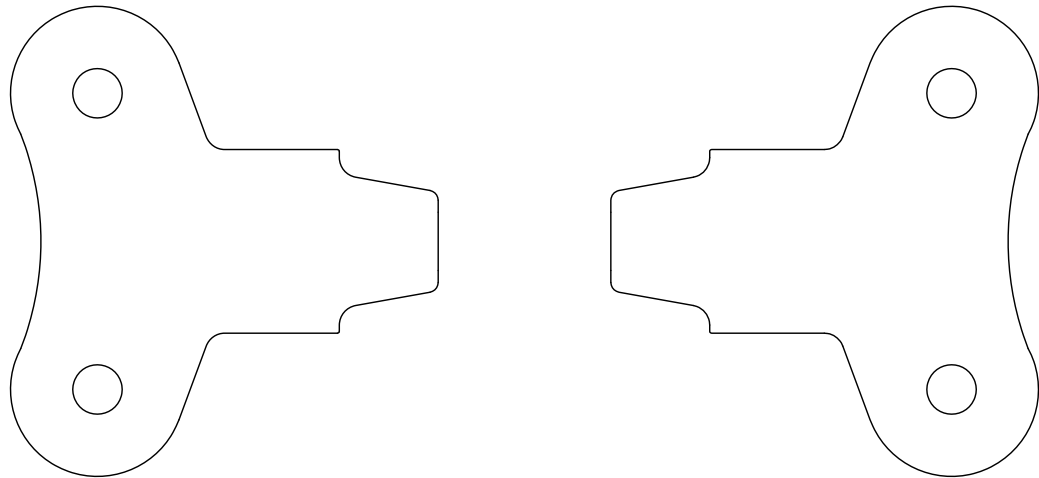

MD5497

**RAMS S-19 VENTERRA**  
**NOSE GEAR TOW PLATE MODIFICATION**  
**FIGURE 09F-02**

04/27/2017



## 12 – OPTIONAL INTERIOR

SIDE PANEL LOCATION.....	12-03
INTERIOR LOGO ORIENTATION.....	12-03A
CLOSE OUT MARKING PINS .....	12A-03

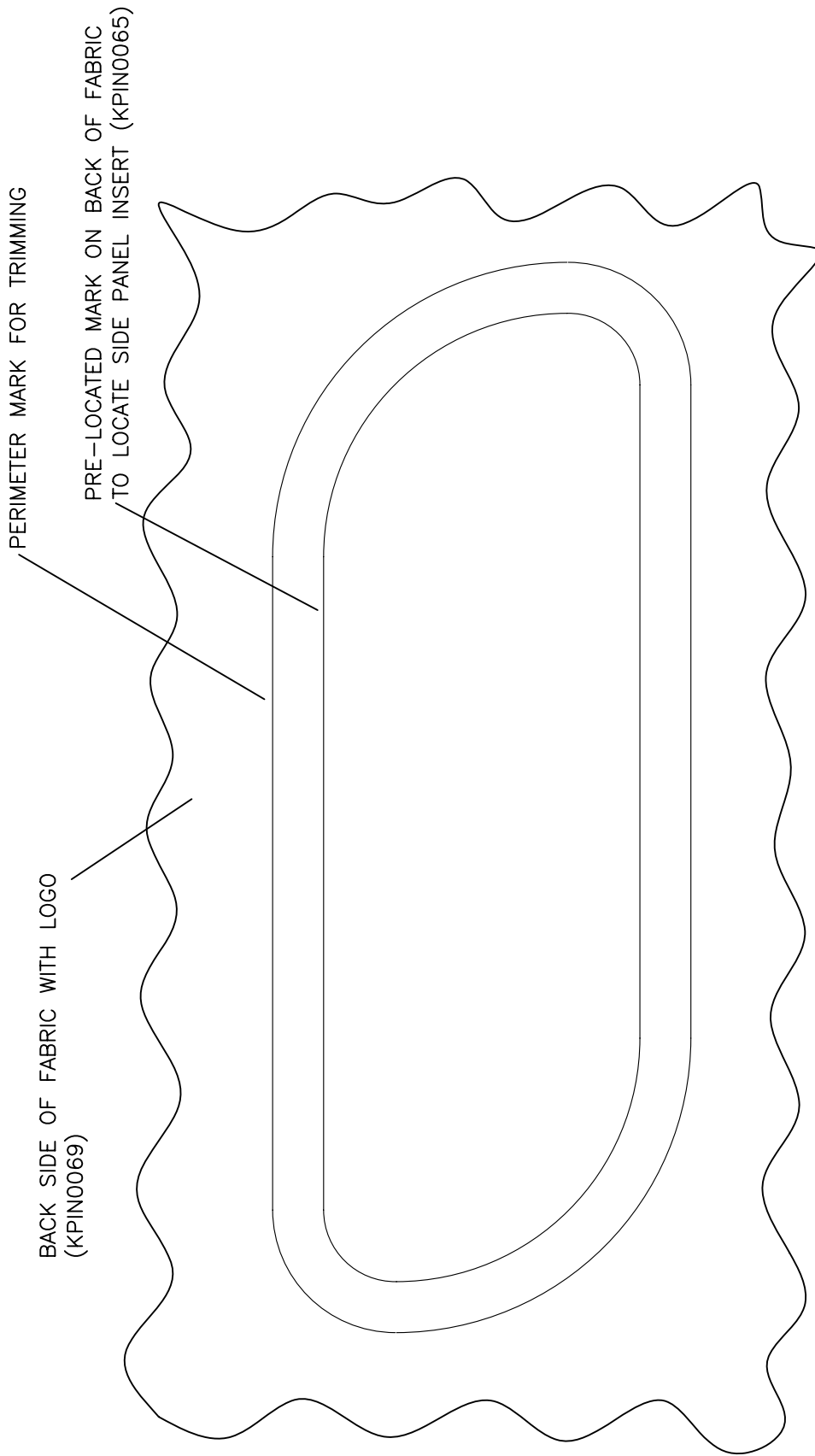

**RRR** S-19 VENTERRA  
SIDE PANEL LOCATION  
FIGURE 12-03

MD5520

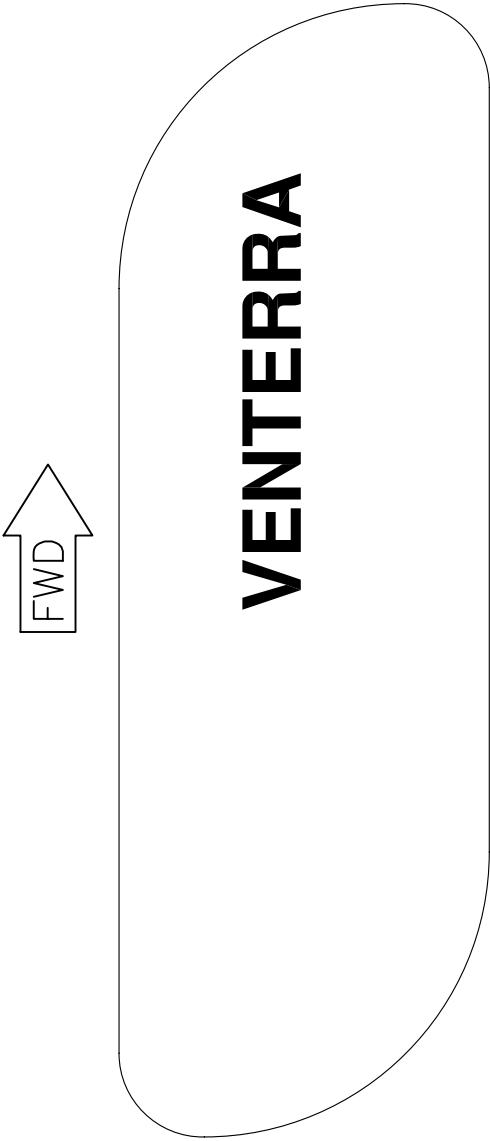

LEFT

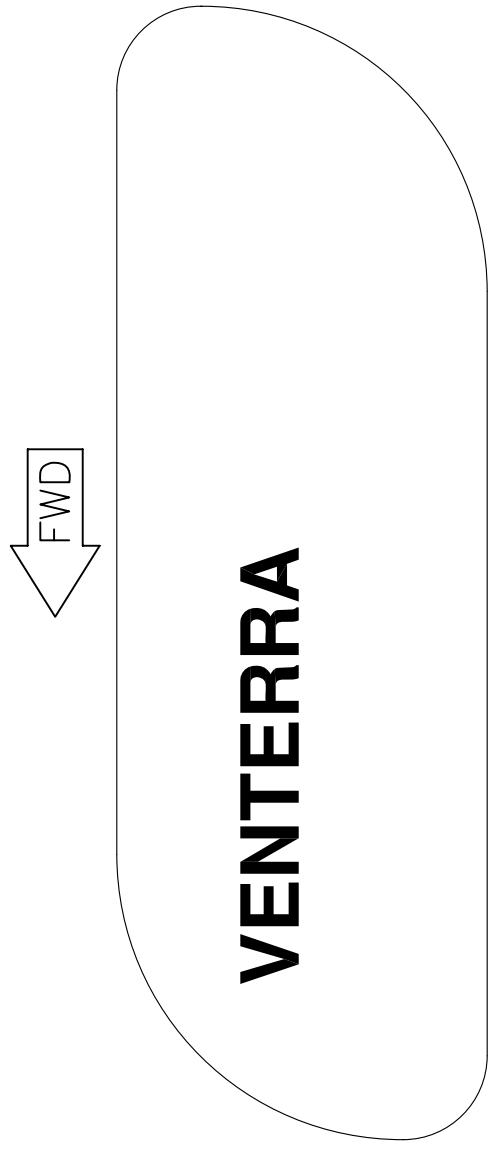

RIGHT

 S-19 VENTERRA  
INTERIOR LOGO ORIENTATION  
FIGURE 12-03A

MD5519

REMOVE

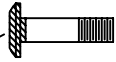

REMOVE



8-32 SCREW OR BOLT

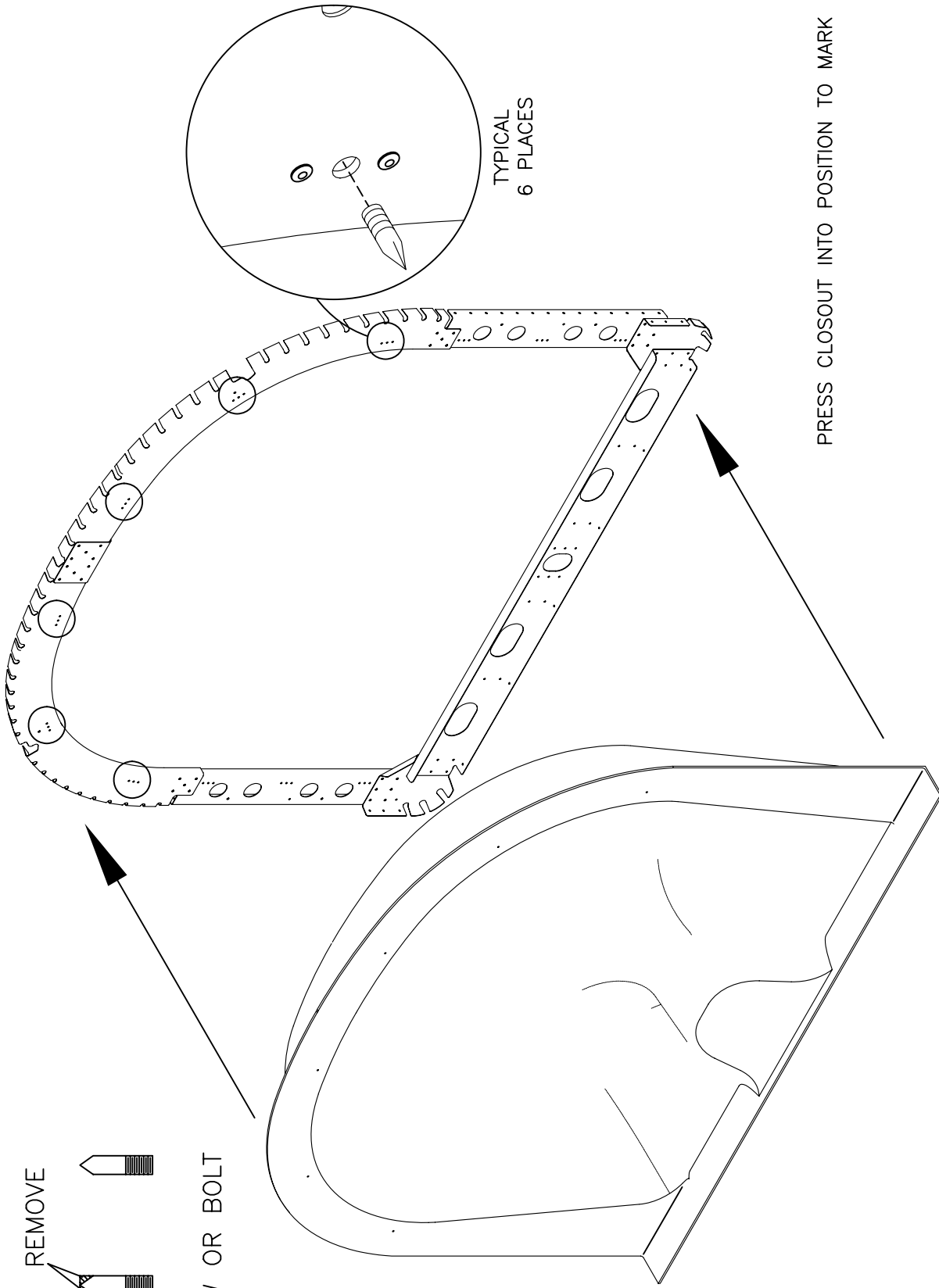

TYPICAL  
6 PLACES

PRESS CLOSOUT INTO POSITION TO MARK

**RRR** S-19 VENTERRA  
 CLOSE OUT MARKING PINS  
 FIGURE 12A-03

## 15 – PREPARATION FOR FLIGHT

RUDDER RIGGING INSTRUCTIONS .....	15-01
STABILATOR RIGGING INSTRUCTIONS .....	15-02
STABILATOR LEVELING .....	15-02A
STABILATOR LEVELING JIG.....	15-02B
STABILATOR LEVELING JIG.....	15-02C
STABILATOR LEVELING JIG.....	15-02D
STABILATOR LEVELING JIG.....	15-02E
STABILATOR LEVELING JIG.....	15-02F
FLAP RIGGING.....	15-04
AILERON RIGGING.....	15-05

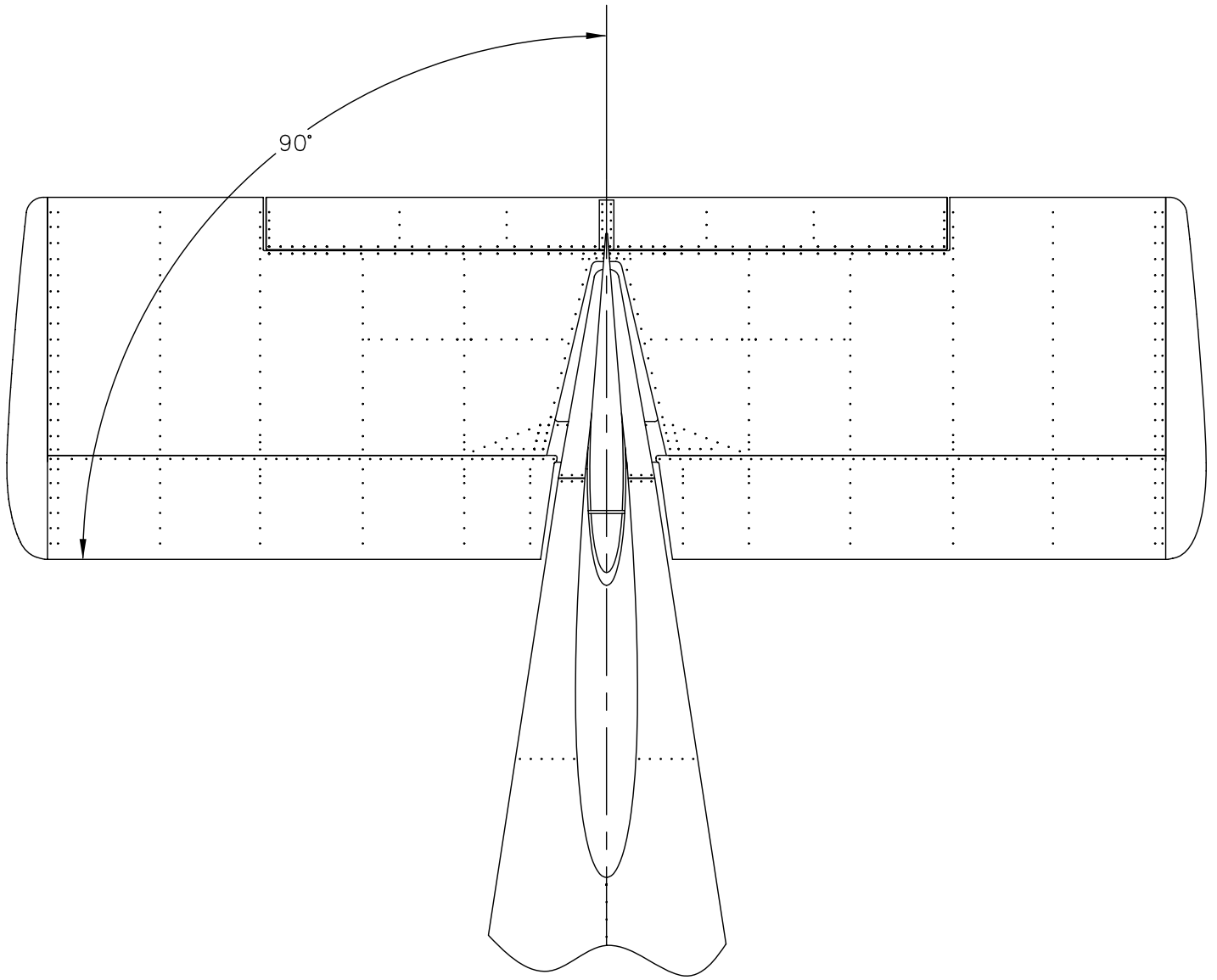

RUDDER PEDALS WILL LINE UP  
AT NEUTRAL

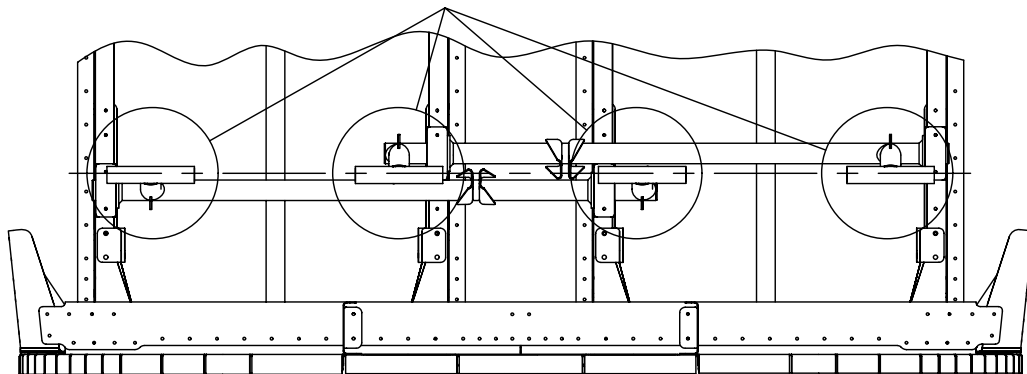

MD5080

**RANS S-19 VENTERRA**  
**RUDDER RIGGING INSTRUCTIONS**  
**FIGURE 15-01**

04/01/2011

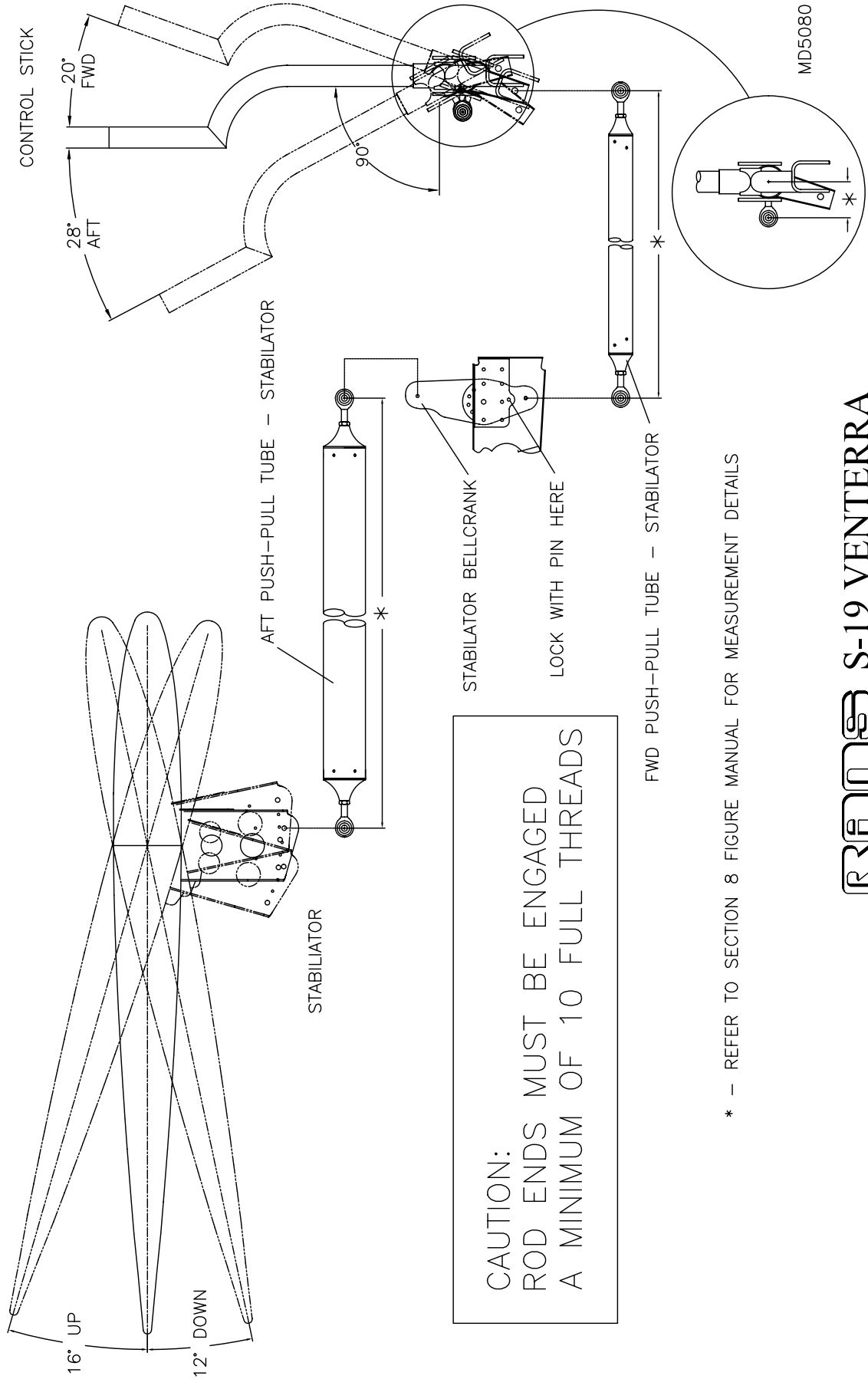

**RRAN S-19 VENTERRA**  
**STABILATOR RIGGING INSTRUCTIONS**  
**FIGURE 15-02**

LEVEL WITH FORWARD  
LONGERON OF FUSELAGE

STABILATOR LEVELING JIG

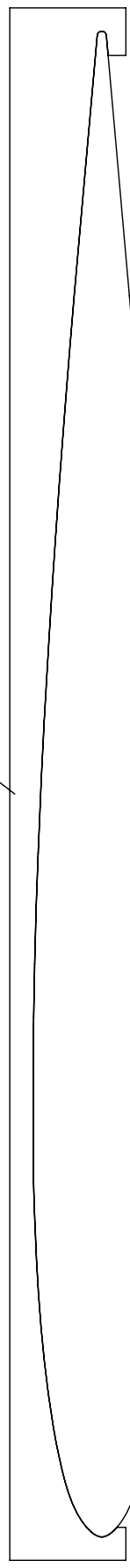

STABILATOR

MD5526

**RAMS** S-19 VENTERRA  
STABILATOR LEVELING  
FIGURE 15-02A

04/01/2011



LINE PAGES UP ON CROSS HAIRS  
(TOP AND BOTTOM)

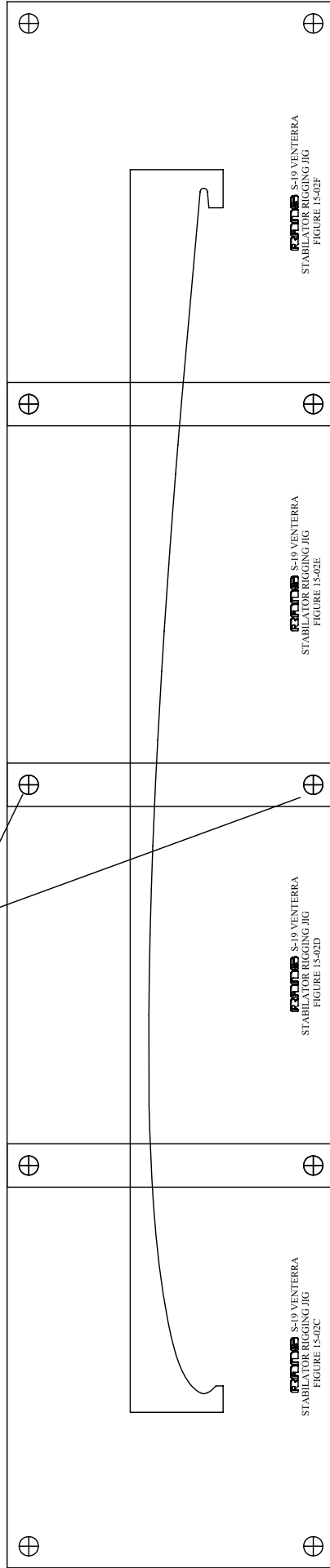

FABRICATE FROM PLY-WOOD OR SIMILAR MATERIAL  
REFER TO FIGURES 15-02C THRU 15-02F

**RAMSES S-19 VENTERRA  
STABILIZER LEVELING JIG  
FIGURE 15-02B**

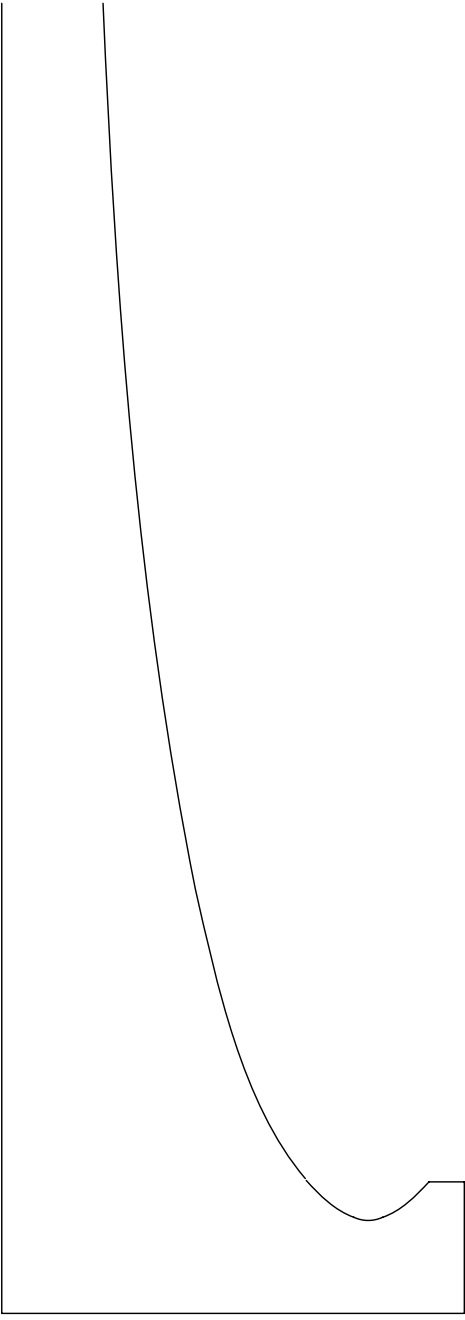

MD5526

**RAMMS S-19 VENTERRA  
STABILATOR LEVELING JIG  
FIGURE 15-02C**

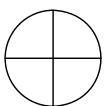
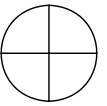
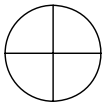

04/01/2011

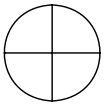
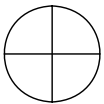

**RRR** S-19 VENTERRA  
STABILATOR LEVELING JIG  
FIGURE 15-02D

MD5526

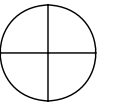

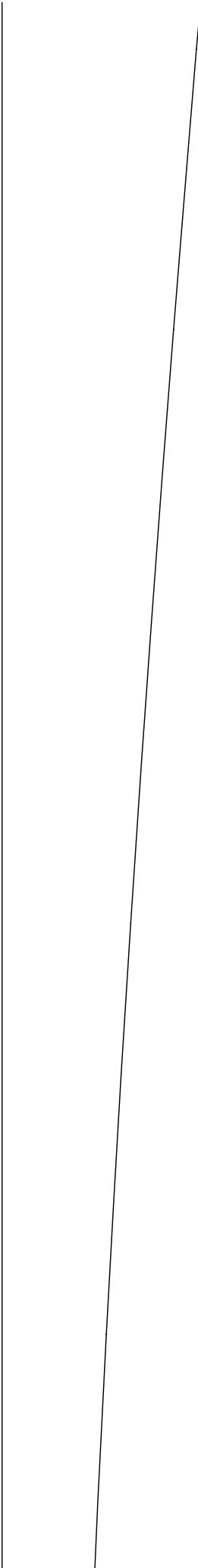
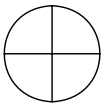
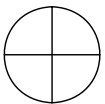

**RAMMS S-19 VENTERRA  
STABILATOR LEVELING JIG  
FIGURE 15-02E**

MD5526

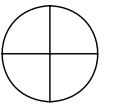

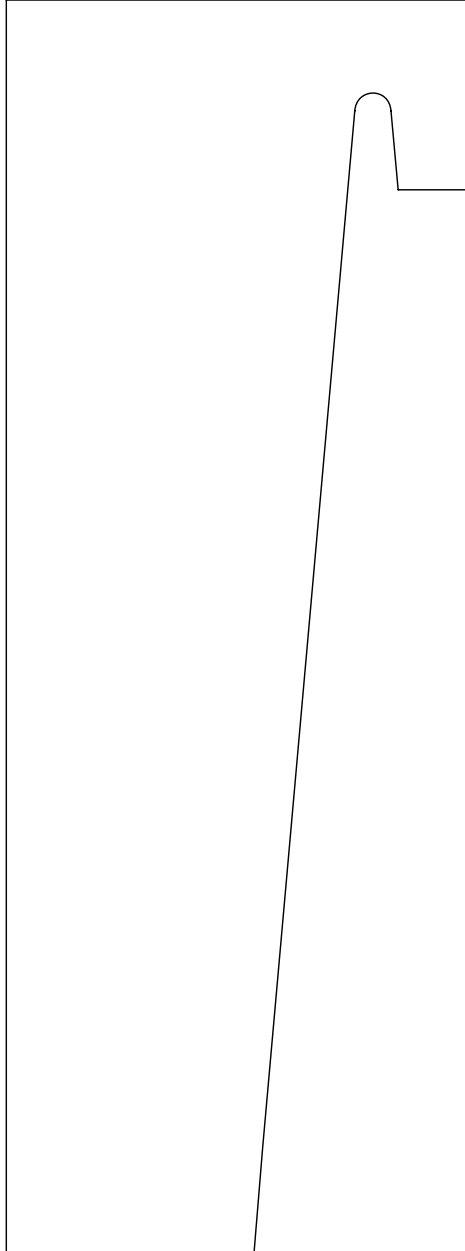

**RRR** S-19 VENTERRA  
STABILATOR LEVELING JIG  
FIGURE 15-02F

MD5526

04/01/2011

CAUTION:  
 ROD ENDS MUST BE ENGAGED  
 A MINIMUM OF 10 FULL THREADS

ROLLER BUSHING  
 ENGAGED IN LOWEST  
 SLOT

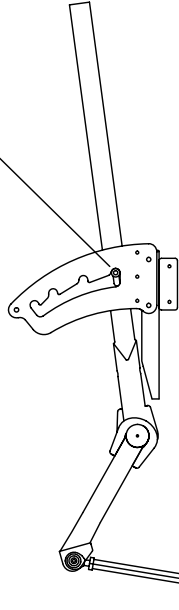

FLAP LEVER

\*ADJUST  
 FLAP PUSH-PULL ROD

\*FLAP PUSH-PULL ROD  
 SHOWN DISCONNECTED  
 FROM FLAP FOR CLARITY

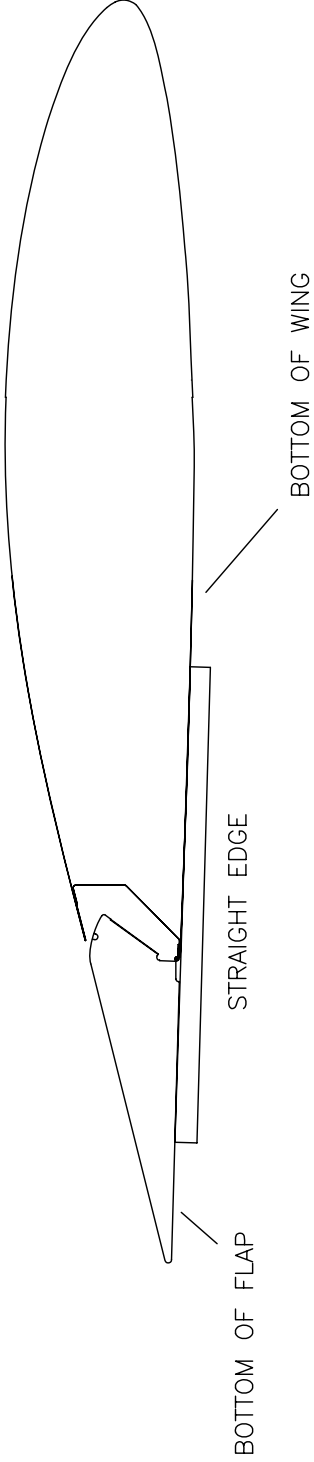

BOTTOM OF FLAP

STRAIGHT EDGE

BOTTOM OF WING

MD5080

**RAMS** S-19 VENTERRA  
 FLAP RIGGING  
 FIGURE 15-04

CAUTION:  
 ROD ENDS MUST BE ENGAGED  
 A MINIMUM OF 10 FULL THREADS

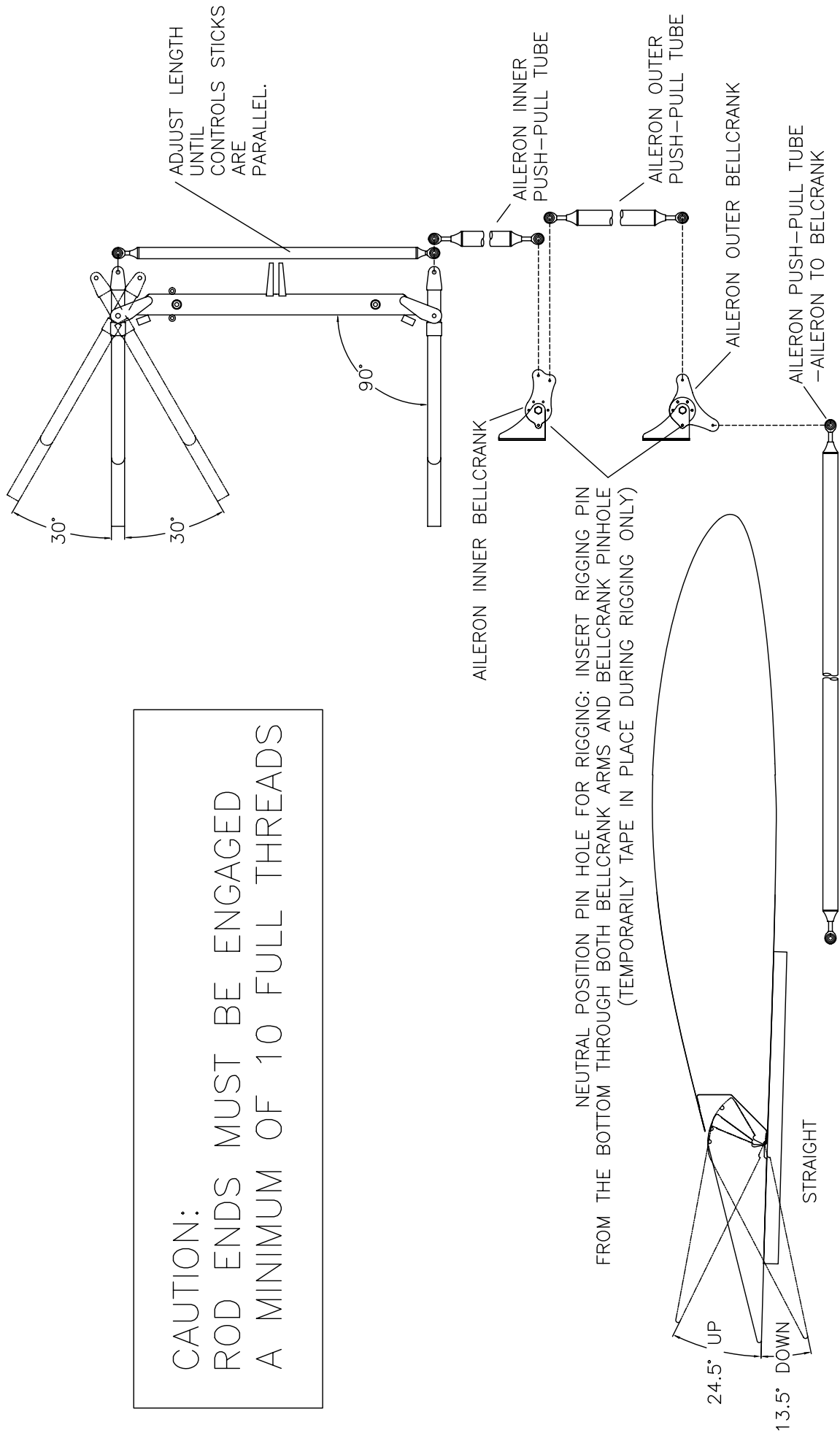

MD5080

**RAMS** S-19 VENTERRA  
 AILERON RIGGING  
 FIGURE 15-05

## **16 – WEIGHT AND BALANCE**

WEIGHT AND BALANCE .....16-01



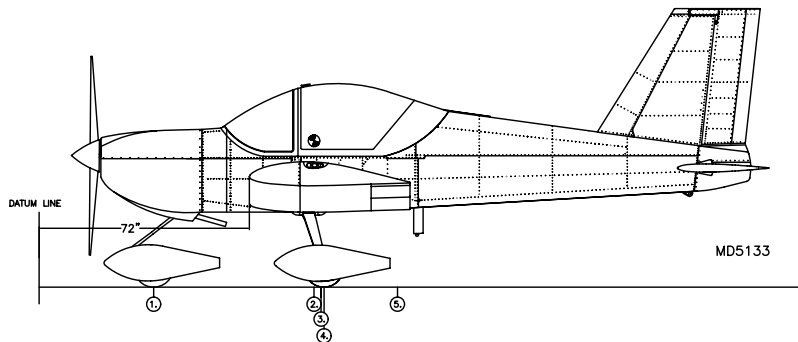

**RANS S-19**  
**WEIGHT AND BALANCE**

N _____	
DATE WEIGHED	
ENGINE TYPE	
C.G. CONDITION	
EMPTY WEIGHT	
MTOW (912 ULS)	1320 LBS.

ACCEPTABLE C.G. 83" TO 91.5" FROM DATUM LINE.  
DATUM LINE IS 72" AHEAD OF WINGS LEADING EDGE.

#	ITEM	WEIGHT	ARM	MOMENT
1	NOSE GEAR	147	39.3"	5777.1
2	PILOT	175	94.0"	16450
2	PASSENGER	160	94.0"	13160
3	FUEL	144	96.3"	13867.2
4	MAIN GEAR - RIGHT	347	97.6"	33867.2
4	MAIN GEAR - LEFT	345	97.6"	33672
5	BAGGAGE*	22	122.7"	2699.4
TOTAL =		1320	TOTAL =	119492.9

$$\frac{\text{TOTAL MOMENTS}}{\text{TOTAL WEIGHT}} = \text{C.G.} = \frac{119492.9}{1320} = 90.5"$$

#	ITEM	WEIGHT	ARM	MOMENT
1	NOSE GEAR		39.3"	
2	PILOT		94.0"	
2	PASSENGER		94.0"	
3	FUEL		96.3"	
4	MAIN GEAR - RIGHT		97.6"	
4	MAIN GEAR - LEFT		97.6"	
5	BAGGAGE*		122.7"	
TOTAL =			TOTAL =	

$$\frac{\text{TOTAL MOMENTS}}{\text{TOTAL WEIGHT}} = \text{C.G.} = \text{_____} = \text{_____}$$

\* 70 POUNDS MAXIMUM BAGGAGE

**RANS S-19 VENTERRA**  
**WEIGHT AND BALANCE**  
**FIGURE 16-01**

04/01/2011