

05 - FUSELAGE – CENTER SECTION

FUSELAGE CARRY-THRU ASSEMBLY.....	05-1
WING SPARS TO CARRY-THRU FIT-UP.....	05-3
FUSELAGE CENTER SECTION - RIB ASSEMBLY.....	05A-1
FUSELAGE CENTER SECTION – SIDE ASSEMBLY	05B-1
FUSELAGE CENTER SECTION – GEAR BLOCK INSTALLATION	05C-1
FUSELAGE CENTER SECTION – SEAT SKIN & ACCESS PANEL INSTALL.....	05D-1

FUSELAGE – CENTER SECTION

FUSELAGE CARRY-THRU ASSEMBLY

- Fuselage assembly must be performed on a flat work surface. Assembly on a warped surface will result in a warped Fuselage
- Sandbags will be required in parts of the assembly to hold the Fuselage flat to the work surface
- Wipe all parts down with acetone to remove markings before assembly
- All parts must have their edges polished smooth before installation to avoid cracking in service.

NOTE: *The S-19 Fuselage is designed to be assembled in 3 separate sections. Those sections are then later mated together. Because of this design any one of the 3 sections may be completed before assembly of the others sections is even started on.*

IMPORTANT: *Check to be sure there is a bevel on the outboard facing ends of the Spar Bars on the Fwd and Aft Center Spar Assemblies. If not, add the bevel and smooth. This bevel will help prevent gouging when installing the Wing Spars.*

1. Become familiar with the fuselage Carry-thru section **Parts Drawings** and collect the parts shown in the drawings. There are parts which must be cut apart to make several parts from one supplied part. Refer to **FIGURE 05-01**. They may be cut apart now or as needed. Be sure to properly label, if you cut them apart.
2. Assemble the Gear Attach Angles (KPMG0176) to the Gear Attach Blocks (KPMG0177) using the hardware shown in the **Parts Drawing**. **IMPORTANT:** *Gear Attach Blocks are **NOT** symmetrical and can be installed upside down. See **FIGURE 05-02**.*
3. Make pins by sanding scrap 3/16" and 3/8" bolts to fit in the undersize holes in the Spar and Carry-thru.
4. Cleco the Gear Attach Angle Assembly to the Aft Center Spar Assembly. **NOTE:** *Pin with modified bolts to insure alignment.* Transfer drill #30 and rivet.
5. Cleco and rivet Aft Angles (KPFU0630) to the Aft Center Spar Assembly (KAFU0046) per the **Parts Drawing**. **NOTE:** *Pin with modified bolts to insure alignment.*
6. Cleco and rivet Forward Angles (KPFU0631) to the Forward Center Spar Assembly (KAFU0047) per the **Parts Drawing**. **NOTE:** *Pin with modified bolts to insure alignment.*

7. Assemble the aft center spar assembly to the forward center spar assembly using the hardware, bushings and angle torque tube attaches (KPCS0231 and KPCS0232) shown in the **Parts Drawing**. Refer to **FIGURE 05-07** for nut plate location and orientation. **NOTE:** *The nut plates are of the “floating” type which will allow adjustment when the Seats are installed.*

WING SPARS TO CARRY-THRU FIT-UP**IMPORTANT:****MATCH REAM WING SPARS TO FUSELAGE SPAR CARRY-THRU !!!**

*This step is best accomplished **before** FINAL assembly of the center section!
If this is not possible, reaming may still be done at a later time.*

- Wipe all parts down with acetone to remove markings before assembly
 - All parts must have their edges polished smooth before installation to avoid cracking in service.
8. Become familiar with the Fuselage center section **Parts Drawings** and collect the Spar Carry-thru and the Wing Spars.
 9. Make pins by sanding scrap 3/8" bolts to fit in the undersize holes in the Spars and Carry-thru.
 10. Pin and clamp these assemblies together exactly as they will be mounted in the airplane. **NOTE:** *It is best if both Spars can be assembled to the Carry-thru and reamed at the same time. If it is not possible to do this, alignment and spacing must be maintained opposite of the holes to be reamed on the Carry-thru.*
 11. Ream each hole to 0.375" and pin with a bolt before moving to the next hole. **IMPORTANT:** *It is recommended to run the ream completely through. Do **NOT** back the ream out.*
 12. After all holes are reamed, Remove the Spars from the Carry-thru and proceed with the assembly of the Fuselage center section.
 13. Radius the ends of the Angle - Gear Attach (KPMG0183). See **FIGURE 05-14**.
 14. Cleco together Angle - Gear Block Attach (KPMG0185) with Angle - Gear Attach (KPMG0183), Rib - Cabin Wall (KPFU0422), Shim (KPMG0184), and Forward Spar Carry-thru.

FUSELAGE CENTER SECTION - RIB ASSEMBLY

- Fuselage assembly must be performed on a flat work surface. Assembly on a warped surface will result in a warped fuselage
 - Wipe all parts down with acetone to remove markings before assembly
 - All parts must have their edges polished smooth before installation to avoid cracking in service.
1. Cleco Seat Ribs (KPST0105) to angles on the Spar Center Section Assembly.
 2. Cleco Flap Mechanism Reinforcement Plates (KPFL0146) to the inner seat ribs. Transfer drill all holes #30. Transfer drill the upper 2 holes #11. Refer to **FIGURE 05A-02**. Position nut plates and transfer drill #40. Remove Reinforcement Plate and drill the #40 holes in the plate only to #11 for rivet clearance. Deburr all parts and rivet.
 3. Assemble the Rear Spar Bulkhead as shown in the **Parts Drawing** and cleco to the Seat Ribs and Cabin Wall Rib (KPFU0422).
 4. Cleco the Baggage Ribs (KPFU0414) and the Floor Stiffener (KPFU0427) to the Rear Spar Bulkhead and Angle bulkhead.
 5. Cleco Rear Spar Attach Plates (KPFU0408) to the Rear Spar Bulkhead.
 6. Cut Fair Leads (KPRD0086) into individual parts per **FIGURE 05A-06**. Locate mounting holes in Bulkheads and Carry-Thru for attaching Fair Leads. Drill these holes to #11. Install Tinnermans. Fair Leads will slip over the Rudder Cables. Attach Fair Leads to Tinnermans with screws.
 7. Fabricate Rear Spar Bulkhead Support Angles from Raw Stock. See **FIGURE 05A-07** for details. Cleco lower end to Rear Spar Bulkhead (KPFU0425) per **Parts Drawing**. Clamp the top end to the inside of the upper tab of the Bulkhead and transfer drill. Transfer drill through forward side of Rear Spar Bulkhead into Support Angle.
 8. Refer to **FIGURE 05A-08** when final installing.
 9. Assemble Tail Cone Bulkhead #1 as shown in the **Parts Drawings**. Refer to the **TAILCONE** section of the manual.
 10. Cleco Tail Cone Bulkhead #1 to the Baggage Ribs.

FUSELAGE CENTER SECTION – SIDE ASSEMBLY

- Fuselage assembly must be performed on a flat work surface. Assembly on a warped surface will result in a warped fuselage
 - Sandbags will be required in parts of the assembly to hold the fuselage flat to the work surface
 - Wipe all parts down with acetone to remove markings before assembly
 - All parts must have their edges polished smooth before installation to avoid cracking in service.
1. Roll a bend in the lower aft portion of the Cabin Side Wall (KPFU0460). See **FIGURE 05B-01**. Refer to **FIGURE 05B-01A** for bend detail.
 2. Copy and glue template from **FIGURE 05B-02** on to each Side Wall after the lower aft edge is rolled. Transfer drill #40 where indicated.
 3. Joggle the Side Stiffeners and Stringers where needed. See **FIGURE 05B-03**. Fabricate the joggle tools and joggle using the procedure shown in **FIGURE 05B-03A**. **NOTE:** *Joggles are required to clear underlying structure. Be sure to joggle in the correct direction.* **HINT:** *you may want to test fit each piece with the Side Wall to determine the joggle.*
 4. Modify Cabin Side Wall Rib (KPFU0422). See **FIGURES 05B-04 and 05B-04A**.
 5. Cleco the Side Wall Stiffeners in place between the Bulkhead, Rear Spar Carry - Thru Assembly, and the Angle - Gear Block Attach. Clips (KPFU0520) will need to be modified per **FIGURE 05B-05**.
 6. Trial fit the Side Walls to insure the stiffeners are in the correct locations. Remove the Side Walls and rivet the Fuselage Center Section Frame together.
 7. Cleco the Side Walls in place.
 8. Form the Forward Longerons (KPFU0574) as shown in **FIGURES 05B-08 & 05B-08A** to match the Longerons Bending Template (KPFU0530). **NOTE:** *Bend a Left and Right hand part.*
 9. Mark a line 0.45" from the aft end of the Longerons. This mark will later line up with the rear hole of the Bulkhead Gusset on the Tail Cone.
 10. Align the top edge of the Forward Longerons with the top edge of the Side Wall. Transfer drill #40 and cleco.
 11. Fabricate 4 shims from Raw Stock. See **FIGURE 05B-11**. Cleco Gussets (KPFU0421) and shims in place at the top of the Gear Block Attach Angles (KPMG0185) and Center Spar Aft Angles (KPFU0630). The gussets must have an edge radiused to properly fit into the angles. See **FIGURE 05B-11**.
 12. Rotate the Fuselage Center Section upside down onto table. Place blocks under the Forward Longerons to avoid bending the side walls.

13. Cleco the Fuselage Center Section Belly Skin (KPFU0430) in place. Refer to **FIGURE 05B-13** for orientation of Belly Skin
14. Cleco the Gusset (KPFU0448) in place on the Belly Skin. Transfer drill the Belly Skin and Gusset through the Gear Attach Block.
15. Cleco the Side Skin Gussets and Seat Belt Channels on the side skins.
16. Transfer drill the Seat Belt bolt holes to 1/4".

FUSELAGE CENTER SECTION – GEAR BLOCK INSTALLATION

- Fuselage assembly must be performed on a flat work surface. Assembly on a warped surface will result in a warped fuselage
 - Sandbags will be required in parts of the assembly to hold the fuselage flat to the work surface
 - Wipe all parts down with acetone to remove markings before assembly
 - All parts must have their edges polished smooth before installation to avoid cracking in service.
1. Cleco the Gear Blocks in place on the side skins.
 2. Transfer drill and ream each Gear Block bolt hole to 0.1885". After each hole is reamed, pin with a bolt before reaming next hole.
 3. After all holes are drilled and reamed to final size (except the holes in the upper longeron, these remain #40), disassemble Fuselage Center Section and deburr.
 4. Cut out reinforcement on side skin. Refer to **FIGURE 05C-04**.
 5. Cleco the Seat Belt Attach Channel to the side skin and rivet the nut plate in place.
 6. Re-assemble and partially rivet together. See rivet schedules **FIGURES 05C-06 and 05C-06A**.

CAUTION: Follow the rivet schedule very closely. Pay very close attention to whether the rivet is an AAPQ or a CCPQ. These rivets may **NOT** be interchanged. Verify rivet length.

FUSELAGE CENTER SECTION – SEAT SKIN & ACCESS PANEL INSTALLATION

- Fuselage assembly must be performed on a flat work surface. Assembly on a warped surface will result in a warped fuselage
 - Sandbags will be required in parts of the assembly to hold the fuselage flat to the work surface
 - Wipe all parts down with acetone to remove markings before assembly
 - All parts must have their edges polished smooth before installation to avoid cracking in service.
1. Cleco Seat Skins, Stiffeners, and Shims together.
 2. Transfer drill #11 for the nut plates. **NOTE:** *Be sure the nut plate is orientated correctly.* See **PARTS PAGES** for reference. Final size drill 1/4" for the "floating" nut plates.
 3. Transfer drill all matching holes #30, except nut plate rivet holes. Deburr and rivet assemblies together, including nut plates.
 4. Cleco Access panels to Seat Ramp Skin and Baggage Deck. Transfer drill #11 and re-cleco as you drill. Deburr and rivet nut plates in place. **NOTE:** *Some holes are intentionally drilled larger to allow the nut plate rivet heads to clear the skins.*
 5. Cleco Baggage Deck Stiffeners to the bottom of the Baggage Deck. Transfer drill #30, deburr, and rivet.
 6. Cleco Seat Ramp, Seat Skin Assemblies, and Baggage Deck in place. Transfer drill #30 and deburr.
 7. Rivet after Tailcone and Fuselage Center Section are mated and riveted.

06 - FUSELAGE – FORWARD SECTION

UPPER FORWARD FUSELAGE ASSEMBLY.....	06-1
FIREWALL ASSEMBLY	06A-1
FUSELAGE FLOOR ASSEMBLY	06B-1
FLOORBOARD INSTALLATION	06C-1
RUDDER PEDAL INSTALLATION	06D-1
FILLING OF THE HYDRAULIC BRAKE SYSTEM.....	06D-2
OPTIONAL PARKING BRAKE INSTALLATION	06D-3
FWD FUSELAGE ASSEMBLY	06E-1
FWD FUSELAGE TO CENTER FUSELAGE INSTALLATION	06F-1
FWD FUSELAGE SKIN INSTALLATION.....	06G-1
ROLL BAR INSTALLATION.....	06H-1

FUSELAGE – FORWARD SECTION

UPPER FORWARD FUSELAGE ASSEMBLY

- Fuselage assembly must be performed on a flat work surface. Assembly on a warped surface will result in a warped fuselage
 - Wipe all parts down with acetone to remove markings before assembly
 - All parts must have their edges polished smooth before installation to avoid cracking in service.
1. Become familiar with the fuselage forward section **Parts Drawings** and collect the parts shown in the drawings.
 2. Cut and profile all clips spacers and stiffeners. Refer back to **FIGURE 05-01**.
 3. Assemble instrument panel frame as shown in the **Parts Drawings**. **NOTE:** *The Panel, panel frame, Fuel Selector Sub-Panel, and Instrument Sub-Panel need to be painted before they are final installed in the airframe.*
 4. Rivet Throttle Reinforcement (KPIP0121) to Instrument Sub-Panel at the pre-drilled location.
 5. Align Instrument Panel Reinforcement (KPFU0652) with throttle opening in Sub-Panel. Drill #30 and rivet in place. **NOTE:** *The slot orients towards the Sub-Panel.*
 6. Assemble instrument panel to instrument panel frame and install all instruments and avionics in the panel and install all switches in the switch plate. **NOTE:** *This is a good time to do all the necessary wiring on your panel. See **INSTRUMENTS & ELECTRICAL SECTION**.*
 7. Remove the instrument panel from the panel frame. Label and remove the switches from the switch plate (*These are now wired together at this point*). Put in a safe place.
 8. Assemble and rivet upper FWD Fuselage Assemblies #2 - #5.

FIREWALL ASSEMBLY

- Fuselage assembly must be performed on a flat work surface. Assembly on a warped surface will result in a warped fuselage
 - Wipe all parts down with acetone to remove markings before assembly
 - All parts must have their edges polished smooth before installation to avoid cracking in service.
1. If your steel firewall parts have not been primed, do so at this time.
 2. Assemble the firewall as shown in the **Parts Drawing**. Refer to **FIGURE 06A-02**.
 3. Transfer drill the firewall to the steel engine mount supports (weldments) at the corners and at the middle bottom of the firewall. **IMPORTANT:** *Transfer drill through the steel engine mount supports (weldments) using the Engine Mount Fitting Plates as guides. Transfer drill from front to back. Do **NOT** transfer drill from the AFT side.*
 4. Disassemble, deburr, and rivet together. Refer to Firewall Rivet Schedule **FIGURE 06A-04**. **NOTE:** *All rivets in the firewall are stainless steel.*

FUSELAGE FLOOR ASSEMBLY

- Fuselage assembly must be performed on a flat work surface. Assembly on a warped surface will result in a warped fuselage
 - Wipe all parts down with acetone to remove markings before assembly
 - All parts must have their edges polished smooth before installation to avoid cracking in service.
1. Assemble the Floor Channels, deburr, and rivet together.
 2. Cleco the Floor Channels to the Firewall.
 3. Cleco Bulkhead Channels to the Floor Channels.
 4. Cleco the Forward Belly Skin in place to hold the assembly square and transfer drill the firewall assembly to the Floor Channels.
 5. Cleco the Floor Channels (KPFU0640) to the Forward Belly Skin. Mark and transfer drill per **FIGURE 06B-05**.
 6. Transfer drill the Forward Belly Skin to the Floor Channels. Remove the Belly Skin and save for later installation.

FLOORBOARD INSTALLATION

- Fuselage assembly must be performed on a flat work surface. Assembly on a warped surface will result in a warped fuselage
 - Wipe all parts down with acetone to remove markings before assembly
 - All parts must have their edges polished smooth before installation to avoid cracking in service.
1. Install the Floorboard and Inspection Panel as shown in the **Parts Drawing**.
NOTE: *The floorboard may need to be filed on the ends to fit properly between the bulkheads.*
 2. Locate the Rudder Pedal attach nut plates per **FIGURE 06C-02**.
 3. Be sure to install nut plates before the Belly Skin is final riveted.

RUDDER PEDAL INSTALLATION

- Fuselage assembly must be performed on a flat work surface. Assembly on a warped surface will result in a warped fuselage
 - Wipe all parts down with acetone to remove markings before assembly
 - All parts must have their edges polished smooth before installation to avoid cracking in service.
1. Assemble Rudder Torque Tube Pillow Blocks with plain nuts to hold the halves together.
 2. Remove any paint or coating from Rudder Pedal Torque Tubes in the locations where the Pillow Blocks contact the Torque Tube.
 3. Using a rotary tool with a 1/2" drum sander attachment, open up the hole until the Rudder Pedal Torque Tube moves freely in the hole.
 4. Install Rudder Pedal Torque Tubes using hardware shown in the **Parts Drawing**.
 5. Assemble pedals and brake cylinders as shown in the **Parts Drawing** and install. **NOTE: If installing Standard Single Side Hydraulic Brakes, fabricate 2 Dummy Brake Cylinders per FIGURE 06D-05.**
 6. **NOTE: Brake system will be plumbed during final assembly.** Install Brake Reservoir and optional Parking Brake Valve on the firewall. Plumb the brake system as shown in **FIGURES 06D-06** thru **06C** depending on the system you are installing. **NOTE: Do NOT forget to bleed the brake system of all air after wheels and brakes are installed.**
 7. Route brake line through fuselage side bulkheads thru grommets and out belly to gear legs. See **FIGURES 06D-07 & 06D-07A**.
 8. Refer to **FIGURE 06D-08** for placement of above items on firewall.
 9. Cut Rudder Cable Keepers into individual pieces per **FIGURE 06D-09**. Do **NOT** misplace the Keepers as 2 will be used later in **Section 08 – Fuselage Systems**.
 10. Rudder cable rigging will be done after the Vertical Stabilizer and Rudder are installed.

FILLING OF THE HYDRAULIC BRAKE SYSTEM

NOTE: These steps should be done during final assembly after installation of the Wheels and Brakes. It may be necessary to move one of the bleed valves to the opposite side of the caliper assembly. Both bleed valves should be on the bottom side of the caliper. Wrap Teflon tape on the bleeder screw to minimize leakage during bleeding. **IMPORTANT:** Use only standard aircraft **MIL-H-5606 Red Hydraulic Fluid**. Improper brake fluid will ruin the brake system seals. **Never use Automotive Brake Fluid!**

Open the lower left bleed valve. With the reservoir cap removed, start filling the system from the bottom. **NOTE:** A small hand held oil pumping can with a short piece of 1/8" ID clear hose (blue primer line works well) attached works well to fill the system. Fill the system until reaching just above the "T". Close the left bleed valve. Open the right bleed valve and fill the system until the air is removed from the right line. Close the right bleed valve.

Check your work by insuring that the reservoir has fluid and that you have a "hard pedal". If you have a "soft pedal", pump the brakes several times. Many times that will fix the problem. Bleed any accumulated air from the system. Tighten the bleeder valves and replace the rubber cap.

When satisfied fill the reservoir to approximately 3/4 full by pouring directly into the reservoir.

Test the brakes **THOROUGHLY** before flying. All air bubbles should be removed from the lines. Any size air bubble could cause insufficient braking. Please taxi test completely before flying.

The non-asbestos organic composition brake pads require a thin layer of glazed material at the lining friction surface in order to provide maximum braking performance. This glazed layer is produced by the heat generated during normal braking operations, and is maintained during the life of the lining. Since new brake pads do not have this layer, it must be created by the following process:

Heat the pads by performing a full stop from 30 mph. **CAUTION:** Only perform once comfortable with the aircraft.

Allow brakes to cool for 5-10 minutes.

Test the brakes at a high static rpm run-up. If the brakes hold, break-in is complete. If they fail to hold, repeat above steps until they do.

For more info refer to www.matcomfg.com

OPTIONAL PARKING BRAKE INSTALLATION

11. Drill the hole in the Park Brake Valve arm to 1/4".
12. Install fittings into Park Brake Valve per parts drawing.
13. Locate Park Brake on firewall per **FIGURE 06D-08**. Drill mounting holes #11 through firewall.
14. Bolt Park Brake Valve to aft side of firewall.
15. Install Adjustable Cable Ferrule into Park Brake Cable Bracket and rivet to top of Firewall Cross Brace (KPFW0021). Adjustable Cable Ferrule should align on outboard side of Park Brake Valve arm.
16. Route Parking Brake Control Cable from Instrument Panel to Adjustable Cable Ferrule. Trim Control Cable housing as needed. **IMPORTANT:** *Pull Control Cable knob out 6" or more before trimming cable housing.* Install Control Cable and secure with safety wire to Park Brake Cable Bracket in 2 places.
17. Slide Primer Line over Control Cable wire and slip through Wire Swivel/Screw Stop in Park Brake valve arm. Push Control knob all the way in. Tighten Swivel/Screw Stop with Park Brake Valve arm in the downward position.
18. Route Brake Line to Park Brake Valve. Refer to **FIGURES 06D-06B** and **06D-06C**.

FWD FUSELAGE ASSEMBLY

- Fuselage assembly must be performed on a flat work surface. Assembly on a warped surface will result in a warped fuselage
 - Wipe all parts down with acetone to remove markings before assembly
 - All parts must have their edges polished smooth before installation to avoid cracking in service.
1. Cleco the Upper Forward Fuselage Assembly to the Firewall Floor Assembly.
 2. Cleco the Bulkhead Sides to the Floor Channels.
 3. Rivet the complete forward fuselage frame together. **NOTE:** *Do not rivet the upper engine mount supports yet. They will need to be transfer drilled through the upper fuselage longerons and removed for deburring.*

FWD FUSELAGE TO CENTER FUSELAGE INSTALLATION

- Fuselage assembly must be performed on a flat work surface. Assembly on a warped surface will result in a warped fuselage
 - Wipe all parts down with acetone to remove markings before assembly
 - All parts must have their edges polished smooth before installation to avoid cracking in service.
1. Slide the Fwd Fuselage Frame on to the Fuselage Forward Longerons. **NOTE:** *The Forward Longerons will have to be spread slightly to allow them to pass the Instrument Panel.* Use Cleco clamps to hold the frame to the longerons.
 2. Cleco the Floor Channels to the Ribs on the Forward Spar Carry-Thru.
 3. Cleco the Forward Fuselage Side Skins in place to position the Forward Fuselage Frame.
 4. Use Cleco clamps to hold the Upper Engine Mount Supports to the Forward Longeron.
 5. Transfer drill #40, through the Upper Engine Mount Support, into the Forward Longeron and cleco.
 6. Drill the holes to #30, disassemble, deburr and cleco.
 7. Transfer drill #40 through the Fuselage Corner Gusset into the Forward Longeron and Engine Mount Support and cleco.
 8. Drill the holes to #30, disassemble, deburr, and rivet.
 9. Rivet the Floor Channels to the Ribs on the Forward Spar Carry-Thru.

FWD FUSELAGE SKIN INSTALLATION

- Fuselage assembly must be performed on a flat work surface. Assembly on a warped surface will result in a warped fuselage
- Wipe all parts down with acetone to remove markings before assembly
- All parts must have their edges polished smooth before installation to avoid cracking in service.

OPTION: An Access Panel may be added to each side of the Forward Fuselage Side Skin if you desire. Refer to **FIGURE 06G-00** for parts and location. Parts may be ordered from RANS Parts Department.

1. The Side Skins must be formed to wrap around the bottom of the fuselage. See **FIGURES 06G-01** thru **06G-01C**.
2. Cleco the skins, spacers, gussets, stiffeners and Cowl Attach Straps to the Forward Fuselage. **NOTE:** *It may be required to place shims between the formers and skins to allow the skins to lay flat. In addition, the corners of some fingers may need to be eased with a file.*
3. Check for alignment of the Fuselage by comparing the angle of the Firewall (measured at the bottom) to the Spar Carry-Thru. **HINT:** *Use a digital protractor for this.*
4. Drill through to the Forward Longeron #40. Check alignment again and drill the Forward Fuselage #30. **IMPORTANT:** *Do NOT forget to install Rudder Pedals and Floorboard area before the Forward Skins are permanently installed.*
5. Disassemble, deburr, and re-assemble. See **FIGURES 06G-05** thru **06G-05B**. Also refer back to **Fuselage Center Section – Rivet Schedule**. **NOTE:** *It may be necessary to re-apply primer to some of the steel parts before final assembly.*
6. Before the Top Skin is completely riveted, fit the Roll Bar in place. See **Roll Bar Installation**. **NOTE:** *The center of the top skin must be riveted before installing the Roll Bar Brace or you will not have access to the holes under the brace. The top skin may require some trimming to clear the Roll Bar Brace.*

ROLL BAR INSTALLATION

- Fuselage assembly must be performed on a flat work surface. Assembly on a warped surface will result in a warped fuselage
 - Wipe all parts down with acetone to remove markings before assembly
 - All parts must have their edges polished smooth before installation to avoid cracking in service.
1. Cleco Cover Channel to Center Spar Angles.
 2. Cleco Channel under Instrument Panel. Note the aft tab will rest against the inboard side of the Cover Channel.
 3. Set the roll bar onto the Top Longeron. **NOTE:** *The larger welded tube on the upper center of the Roll Bar will be to the front.* Align the Forward hole of the Roll Bar base with the aft tab of the Cover. Transfer drill #40 and Cleco. **IMPORTANT:** *Check to be sure the Roll Bar is perpendicular (90-degrees) to the Top Longeron.* Transfer drill #30 and Cleco.
 4. Insert the Roll Bar Brace into the Roll Bar stub tube on the upper center of the Roll Bar. Check for full insertion into the stub.
 5. Cleco the lower end of the Roll Bar Brace to the Upper Forward Fuselage Assembly. See **FIGURE 06H-05**. The Roll Bar Brace's upper end may need to be trimmed to length to allow the lower end to Cleco into place. **IMPORTANT:** *Check to be sure the Roll Bar is perpendicular (90-degrees) to the Top Longeron.* **NOTE:** *Trim only as much as needed to allow alignment.*
 6. Transfer drill #30, through both sides of the stub. Cleco as you drill. Step drill to 1/4".
 7. Transfer drill the 2 holes on the lower end of the Roll Bar Brace to #11. Be sure to note which hole will remain #30 for the 1/8" rivet. Disassemble, deburr, and paint as desired. Remember to rivet the Top Skin, which is under the brace, before brace final installation. **NOTE:** *If installing a Pedestal Mount Compass, you may wish to degauss the Roll Bar Brace.*

07 - FUSELAGE – TAILCONE

FUSELAGE TAILCONE SIDE & BELLY ASSEMBLY.....	07-1
BELLCRANK CHANNEL ASSEMBLY	07A-1
TAILCONE INSPECTION PLATE INSTALLATION	07B-1
BULKHEAD #1 ASSEMBLY	07C-1
BULKHEAD #1, 2, 3 INSTALLATION	07D-1
FOOT STEP INSTALLATION	07E-1
BULKHEAD #4, 5 AND REAR DECK ASSEMBLY	07F-1
TAILCONE TOP SKIN INSTALLATION.....	07G-1
MATING TAILCONE TO FUSELAGE CENTER SECTION	07H-1
TAILCONE STINGER INSTALLATION.....	07I-1

FUSELAGE – TAILCONE

FUSELAGE TAILCONE SIDE & BELLY ASSEMBLY

- Fuselage assembly must be performed on a flat work surface. Assembly on a warped surface will result in a warped fuselage
- Sandbags will be required in parts of the assembly to hold the fuselage flat to the work surface
- Wipe all parts down with acetone to remove markings before assembly
- All parts must have their edges polished smooth before installation to avoid cracking in service.

NOTE: A 2" dia. x 120" long Aluminum (or PVC) Tube will be required for forming the Tailcone Side Skin.

1. Become familiar with the fuselage tailcone **Parts Drawings** and collect the parts shown in the drawings.
2. Determine Left and Right of the Tailcone Side Skins (KPFU0469-L/R). **HINT:** Cleco Sidewall Gussets (KPFU0494-L/R) to the inside of the Tailcone Side Skins (KPFU0469-L/R) for easier identification. Mark the lower inside of the skins for easier identification. Remove Gussets.
3. Form the lower edge of the Fuselage Tailcone Side Skins (KPFU0469-L/R). See **FIGURE 07-03**. **NOTE:** Bend with the 2" tube only enough to bring the skin to a final shape of about 90-degrees.
4. After bending, cut fingers in the lower forward edge of the side skins. Use the template on **FIGURE 07-04**.
5. Tailcone Stringers should have been joggled previously in the fuselage section. If not refer to **Section 05 – Fuselage – Center Section**.
6. Feather the edges of the Sidewall Gusset (KPFU0494-L/R) as shown in **FIGURE 07-06**.
7. Install nut plates and Inspection Plates in the belly and side skins.
8. Cleco tailcone side skin assemblies as shown in the **Parts Drawings** (Tailcone Side Skin Aft Assembly and Tailcone Assembly #1).
9. Cleco tailcone belly skin assembly as shown in the **Parts Drawings** (Tailcone Assembly #2 and #3). Orientate Tailcone Belly Skin per **FIGURE 07-09**.
10. This is a good time to rivet the push-pull tube guide in place on Bulkhead #3 as shown in the **Parts Drawing**. Refer to Aft Stabilator Push-Pull Tube Installation **Section 08 – Fuselage Systems**.

11. Cleco and rivet the tailcone sides together with the tailcone belly at the bulkheads as shown in **Parts Drawing** (Tailcone Assembly #4).
12. Slide the corner stiffeners - belly in place and cleco the side skins to the belly and the corner stiffeners.
13. Assemble Bulkhead #5 (Bulkhead #5 Assembly and Installation). **NOTE:** *Disassemble, deburr, and rivet, Bulkhead #5 together.* See **FIGURE 07-13** for rivet schedule. **IMPORTANT:** *Do NOT rivet where the bulkhead fits against the tailcone assembly.* Cleco Bulkhead #5 to the tailcone assembly.
14. Drill all holes final size, and ream the bolt holes to a tight fit. **NOTE:** *Position all bulkhead and tie down parts in place before drilling final size.* **IMPORTANT:** *Transfer drill the Channel – Stabilator Attach – Lower (KPFU0495) using the pre-drilled holes in the Corner Stiffener – Side (KPFU0471) as a guide.*
15. Deburr, rivet/bolt assemblies together. See **FIGURE 07-15 & 07-15A** for rivet schedule. **IMPORTANT:** *Rivet the Channel – Stabilator Attach – Lower and the Corner Stiffener – Side together before riveting to the side skins.* **CAUTION:** *Do NOT rivet **Corner Stiffener – Belly (KPFU0467)** at this time.*

BELLCRANK CHANNEL ASSEMBLY

- Fuselage assembly must be performed on a flat work surface. Assembly on a warped surface will result in a warped fuselage
 - Wipe all parts down with acetone to remove markings before assembly
 - All parts must have their edges polished smooth before installation to avoid cracking in service.
1. Become familiar with the Bellcrank Channel and Aft Stabilator Push-pull Tube **Parts Drawings** and collect the parts shown in the drawings. Refer to **Section 08 – Fuselage Systems** for Push-Pull Tube.
 2. Cleco the Bellcrank Channel Assembly together. Rivet Bellcrank Attach to respective Bellcrank Attach Channel. Refer to **FIGURE 07A-02**. **NOTE:** *Rivets are installed from inboard side.*
 3. Stabilator Bellcranks and Pulleys may be assembled and fit into the Bellcrank Channel at this time. Refer to Aft Stabilator Push-Pull Tube Installation **Section 08 – Fuselage Systems**.
 4. Cleco the Bellcrank Channel Assembly to the Belly Skin and Bulkhead #2.
 5. Drill final size, deburr, and rivet.

TAILCONE INSPECTION PLATE INSTALLATION

- Fuselage assembly must be performed on a flat work surface. Assembly on a warped surface will result in a warped fuselage
 - Wipe all parts down with acetone to remove markings before assembly
 - All parts must have their edges polished smooth before installation to avoid cracking in service.
1. Become familiar with the Tailcone Inspection Plates Installation **Parts Drawings** and collect the parts shown in the drawings.
 2. Cleco the Access Panel Rings to the Tailcone Skins.
 3. Transfer drill #30 for ring to skin attachment. **CAUTION: Do NOT drill the holes for nutplate attachment to #30. They must remain #40. Deburr and rivet the rings to the skins.**
 4. Cleco the Access panels to the Access Rings.
 5. Transfer drill #11, re-cleco as you drill. Remove and deburr.
 6. Rivet nutplates to inside of Access Rings and Tailcone Skins. See **FIGURE 07B-06** for rivet schedule.
 7. Re-attach Access Rings with Trusshead screws.

BULKHEAD #1 ASSEMBLY

- Fuselage assembly must be performed on a flat work surface. Assembly on a warped surface will result in a warped fuselage
 - Wipe all parts down with acetone to remove markings before assembly
 - All parts must have their edges polished smooth before installation to avoid cracking in service.
1. Become familiar with the Bulkhead #1 Assembly **Parts Drawings** and collect the parts shown in the drawings.
 2. Assemble and rivet lower Bulkhead #1 together. See **FIGURE 07C-02**. Assemble and rivet upper Bulkhead #1 together. Refer to **FIGURE 07C-02 & FIGURE 07C-02A** for details. **IMPORTANT: Do NOT Rivet upper and lower portions of #1 bulkhead together at this time.**
 3. Cleco Bulkhead #1 in place in the tailcone. **CAUTION: Do NOT rivet.**
 4. Before final installation of the lower set of Side Wall Stiffeners (KPFU0473) remove the aft tab as shown in **FIGURE 07C-04**. **NOTE: These parts must be riveted to Bulkhead #1 before the Bulkhead is final installed into the tailcone.**

BULKHEAD #1, 2, 3 INSTALLATION

- Fuselage assembly must be performed on a flat work surface. Assembly on a warped surface will result in a warped fuselage
 - Wipe all parts down with acetone to remove markings before assembly
 - All parts must have their edges polished smooth before installation to avoid cracking in service.
1. Cleco upper Bulkhead #1 in place with the Bulkhead Gusset (KPFU0514).
 2. Cut the Tailcone Longerons (KPFU0517) to length, drill, and trim to shape. See **FIGURE 07D-02**.
 3. Align the forward end of the Tailcone Longeron on top of the Bulkhead Gusset (KPFU0514) per **FIGURE 07D-03**. **NOTE:** *The hole in the Longeron should line up with the forward hole in the Bulkhead Gusset.*
 4. Clamp the Longeron in place with cleco clamps. The top edge of the Longeron should be even with the top edge of the skin. See **FIGURE 07D-04**.
 5. Transfer drill through the Tailcone Side Skins into the Tailcone Longeron #40 and cleco.

FOOT STEP INSTALLATION

- Fuselage assembly must be performed on a flat work surface. Assembly on a warped surface will result in a warped fuselage
 - Wipe all parts down with acetone to remove markings before assembly
 - All parts must have their edges polished smooth before installation to avoid cracking in service.
1. Become familiar with the Foot Step Installation **Parts Drawings** and collect the parts shown in the drawings.
 2. Cleco lower Bulkhead #1 into the tailcone.
 3. Insert the Foot Step through the hole in the Tailcone Belly Skin. Enlarge the hole if needed for clearance.
 4. Bolt to Bulkhead #1.
 5. Slide the Foot Step Patch over the Foot Step and Cleco to the Fuselage.
 6. Slip the Rubber Trim onto the top of the Foot Step Fairing. Tape in place if needed. Do **NOT** glue at this time.
 7. Slip the Foot Step Fairing onto the Foot Step. Slide the un-bent trailing edge tight into the bent trailing edge. Transfer drill trailing edge #40 and Cleco.
 8. Slide the footstep tight against the fuselage belly. Orientate the Fairing to be parallel with the airflow (parallel to the fuselage centerline). Center the Fairing holes on the Foot Step and transfer drill #40. Final size #30.
 9. Remove fairing and paint. Glue Rubber Trim to top of Fairing. Slip Fairing over Foot Step, rivet trailing edges together with #40 rivets. Rivet Fairing to Foot Step.

BULKHEAD #4, 5 AND REAR DECK ASSEMBLY

- Fuselage assembly must be performed on a flat work surface. Assembly on a warped surface will result in a warped fuselage
 - Wipe all parts down with acetone to remove markings before assembly
 - All parts must have their edges polished smooth before installation to avoid cracking in service.
1. Assemble and rivet Bulkhead Top #4 in place. See **FIGURE 07F-01** for rivet schedule.
 2. Assemble and rivet Bulkhead #5 in place. Refer back to **FIGURE 07-13** for rivet schedule.
 3. Assemble and rivet stiffeners to Rear Deck Closeout Skin. **IMPORTANT: Do NOT rivet the outboard holes of the middle stiffener (KPFU0487); they will need to be transfer drilled to the Tailcone Longerons.**
 4. Cleco the Vertical Stabilizer to the appropriate bulkheads.
 5. Transfer drill and ream the holes that mount the Vertical Stabilizer to the Tailcone.
 6. Verify that the Vertical Stabilizer is perpendicular to a straight-edge placed across the Tailcone Longerons at the forward end of the Tailcone as shown in **FIGURE 07F-06**.
 7. Drill the Rear Deck Closeout Skin to the Tailcone Longerons and cleco. **IMPORTANT: It is VERY IMPORTANT that the tailcone is aligned properly when the Closeout Skin is drilled.** This locks the tailcone in position.
 8. Cleco the Pulley Attach Brackets (KPRD0081) to the forward side of Bulkhead #4.
 9. Fabricate the bushing and bolt the pulley between the brackets. Install the cotter pin after the Rudder Cables have been installed.
 10. Remove the Vertical Stabilizer for installation at a later time.
 11. Disassemble, deburr, and rivet.

TAILCONE TOP SKIN INSTALLATION

- Fuselage assembly must be performed on a flat work surface. Assembly on a warped surface will result in a warped fuselage
 - Wipe all parts down with acetone to remove markings before assembly
 - All parts must have their edges polished smooth before installation to avoid cracking in service.
1. Assemble the Tailcone Top Skin Stiffeners to the Tailcone Top Skins and rivet.
 2. Slightly break over the top edge of the right-hand Tailcone Top Skin using a hand flanging tool. This will allow the skin edge to lay tight against the underlying skin.
 3. Assemble and rivet the Top Skins together. **IMPORTANT:** Do **NOT** rivet the 7 forward holes where the Seat Belt Attach Angle (KPFU0659) will install.
 4. Lay the Top Skin Assembly over the Tailcone and Cleco starting at the top of the bulkheads. Pull the Top Skins down to the Side Skins using strapping tape.
 5. Transfer drill #30 through the skins into Tailcone Longeron and Cleco.
 6. Cleco the Seat Belt Attach Angle (KPFU0659) onto the Top Skins. Cleco the Seat Belt Gussets (KPFU0660) under the Top Skins, but over the top of the #1 Bulkhead tabs. Refer to **FIGURE 07G-06**.
 7. Disassemble, deburr, and rivet. **IMPORTANT:** Do **NOT** rivet from Bulkhead #1 forward as this is the Center to Tailcone Sections mating area. **NOTE:** Install Rudder Cables before final riveting the Top Skins. Refer to **FIGURE 07G-06** for Seat Belt Attach Angle and Gusset rivet schedule. Also refer to Rivet Schedules **FIGURES 07H-09, 07H-09A, and 07H-09B**.

MATING TAILCONE TO FUSELAGE CENTER SECTION

- Fuselage assembly must be performed on a flat work surface. Assembly on a warped surface will result in a warped fuselage
 - Wipe all parts down with acetone to remove markings before assembly
 - All parts must have their edges polished smooth before installation to avoid cracking in service.
1. Become familiar with the Tailcone to Center Section Installation **Parts Drawings** and collect the parts shown in the drawings.
 2. Place the Tailcone and Center Section on your work table.
 3. Walk the sections toward each other pulling outward on the Center Section Skins so they overlap the Tailcone Skins.
 4. Pay attention to the overlap of the skins. This is important for the proper fitting of the parts.
 5. Cleco the pieces together. Check that all of the holes align properly.
 6. Pull the seams at the lower corners of the fuselage sections together with tape to eliminate any gap.
 7. Transfer drill through the holes in the fuselage corners and cleco. **NOTE:** *The fingers in the bulkhead must be supported from the inside when drilling.*
 8. Remove clecos, pull the sections apart, and debur.
 9. Place the sections back together and rivet. See Rivet Schedules **FIGURES 07H-09, 07H-09A, and 07H-09B.**
 10. Turn the fuselage over on the table.
 11. Rivet the forward portion of the Bell Crank Box to the bulkhead.

TAILCONE STINGER INSTALLATION

1. Become familiar with the Tailcone Stinger Installation **Parts Drawings** and collect the parts shown in the drawings. **NOTE:** *The Stinger will install inside of the Fuselage Skins.* Final fit-up will require the Stabilator and Rudder to be at least temporarily installed.
2. Trim Stinger halves to the trim lines. **NOTE:** *The Lower Stinger is cut from a single formed piece and is glued together.* Refer to **FIGURE 07I-02**. **IMPORTANT:** *Do NOT glue together until Stinger has been fit to the Tailcone.*
3. Place the Lower Stinger halves in place inside the Tailcone skins and tape together. **IMPORTANT:** *Be sure the top edge is level with the Fuselage.* The Stinger must be tight against the inside of the Tailcone skins. Trim the forward end as needed so the aft end of the Stinger is 19" from the aft side of Bulkhead #5. Refer to **FIGURE 07I-03**.
4. Tape the Upper Stinger into place. **NOTE:** *Be sure to leave an even gap, between the Stinger and Rudder.* Trim as needed to allow the Upper Stinger to insert fully into the Fuselage. Tape the upper and lower halves together. Trim any overlap of the bottom joggle as needed for a perfect fit.
5. Glue **FIGURE 07I-05** on to poster paper. Align with Stabilator Attach Angle on each side, mark and cut out the opening for the Stabilator. Attach Stabilator and check for clearance of 1/4" to 3/8". Trim and move Stinger forward to obtain needed clearance. Transfer drill #40 and cleco through the fuselage attachments.
6. Space #40 holes along the Upper and Lower Stinger overlap per **FIGURE 07I-06**. Cleco as you drill. Remove Stinger and glue bottom halves together with PVC cement.
7. Mark and cut out the aft end of the Stinger per **FIGURE 07I-06**. Temporary installation of the Stabilator, Anti-servo Tab, and Trim Push-Pull Tube will assist in final trimming of the opening.
8. Remove the Upper Stinger. Align the Stiffener Angle with the top inside edge of the Lower Stinger and flush with the aft edge of the Stabilator cut-out. Clamp and transfer drill. Drill #40 between the tinnerman holes and rivet the Stiffener Angles in place. Final size the holes in the Stiffener Angle and Lower Stinger for the tinnermans to #11 and install.
9. Trim Stinger Bulkhead per **FIGURE 07I-09**. Temporarily install Stinger Bulkhead into Lower Stinger with tape. Slide the bulkhead fore or aft until the stinger sides are parallel to the Stabilator opening. No bulge should be formed by the Bulkhead. Start with a location approximately 9 1/8" from the aft end of the Stinger. Refer to **FIGURE 07I-03**. **IMPORTANT:** *Ensure clearance of 1/4" to 3/8" between the Stinger and Stabilator.* Mark the location and glue in place with PVC cement. **NOTE:** *The top side of the bulkhead will be below the Stiffener Angles.*
10. Install all hardware.
11. Remove, paint, and re-install.

08 - FUSELAGE – SYSTEMS

CONTROL STICK ASSEMBLY.....	08-1
AFT STABILATOR PUSH-PULL TUBE INSTALLATION.....	08-2
STABILATOR DOWN BUNGEE INSTALLATION.....	08-2
FUEL SHUT OFF VALVE INSTALLATION.....	08A-1
FLAP HANDLE INSTALLATION.....	08B-1
FLAP PUSH ROD FUSELAGE EXIT.....	08B-2
TRIM SERVO INSTALLATION.....	08C-1
OPTIONAL FUSELAGE VENTILATION SYSTEM.....	08D-1
OPTIONAL AVIONICS HEAT EXHAUST FAN INSTALLATION.....	08E-1

FUSELAGE – SYSTEMS

CONTROL STICK ASSEMBLY

- Fuselage assembly must be performed on a flat work surface. Assembly on a warped surface will result in a warped fuselage
 - Wipe all parts down with acetone to remove markings before assembly
 - All parts must have their edges polished smooth before installation to avoid cracking in service.
1. Become familiar with the Control Stick Assembly **Parts Drawings** and collect the parts shown in the drawings.
 2. Assemble Forward Push-Pull Tube. Press End Fittings fully into each end of the Push-Pull Tube. Transfer drill #30 and rivet. Screw Rod Ends into each end and set per **FIGURE 08-02**. **IMPORTANT: Make sure the Rod Ends are engaged at least 10 full threads.** Do **NOT** forget the Locking Nuts.
 3. Install Rod Ends into Control Stick Torque Tube per **FIGURE 08-03**. **IMPORTANT: Make sure the Rod Ends are engaged at least 10 full threads.** Do **NOT** forget the Locking Nuts.
 4. Thread the 1/4" Plain Bolts into the 4 welded bushings on the Torque Tube. These will be used as control throw stops. Do **NOT** forget the Locking Nuts.
 5. Bolt Torque Tube to Attach Angle on the Forward side of the Spar Carry-Thru.
 6. Bolt Control Sticks to Torque Tube.
 7. Install Rod Ends into Control Stick Interconnect Push Rod. **IMPORTANT: Make sure the Rod Ends are engaged at least 10 full threads.** Do **NOT** forget the Locking Nuts. Temporarily install the Push Rod to the Control Sticks. Adjust Rod Ends to set the Control Sticks parallel to each other. **NOTE: Final installation will include push-pull tubes from the wings.**
 8. Bolt FWD Stabilator Push-Pull Tube to lower horns of Torque Tube and bottom of Bellcrank.

AFT STABILATOR PUSH-PULL TUBE INSTALLATION

9. Assemble the Stabilator – Bellcranks (KPCS0237), Bearings and Bearing Flanges. See **FIGURE 08-09**. **NOTE:** *Be sure to make a Left and Right Hand.*
10. The Cable Keepers should have been cut into individual parts earlier. If not, refer to **Rudder Pedal Installation** in **Section 06 – Forward Fuselage**.
11. Cut bushings to length and assemble Bellcranks, Pulleys, and Cable Keepers to Bellcrank Channel. **NOTE:** *Rudder Cables should be installed before final bolting the Pulleys into place.*
12. Assemble the Aft Push-Pull Tube. Insert End Fitting fully into Push-Pull Tube. Transfer drill #30 and rivet. Screw Rod Ends into each end and set per **FIGURE 08-12**. **IMPORTANT:** *Make sure the Rod Ends are engaged at least 10 full threads.* Do **NOT** forget the Locking Nuts.
13. Slide Push-Pull Tube into place and bolt forward end to top of Bellcrank. Bolt aft end to Stabilator Horn. Be sure the Push-Pull Tube passes through the Guide at Bulkhead #3.

STABILATOR DOWN BUNGEE INSTALLATION

14. Pull Control Sticks full aft. Mark a line on the FWD Push-Pull Tube just aft of the Carry-Thru.
15. Slip free end of S-Hooks on Stabilator Down Bungee through hole in Eyebolt and top hole in Attach Angle. Close S-Hooks with pliers or Vise.
16. Install Eyebolt through hole in base of Flap Mechanism Weldment.
17. Push control sticks forward and secure Attach Angle to top of FWD Push-Pull Tube with Hose Clamps. The forward end of the Attach Angle will align with previously located mark. **NOTE:** *Be sure the Attach Angle is oriented correctly. The vertical portion of the tang will be forward.* Refer to **FIGURE 08-17** for details.
18. Pull Control Sticks aft to stop limit. **IMPORTANT:** *The Attach Angle should just clear the aft side of the Carry-thru.*
19. Adjust Attach Angle position as needed to obtain the correct down force reading. Refer to **FIGURE 08-17**.
20. Loctite Hose Clamps after final setting.

FUEL SHUT OFF VALVE INSTALLATION

- Fuselage assembly must be performed on a flat work surface. Assembly on a warped surface will result in a warped fuselage
 - Wipe all parts down with acetone to remove markings before assembly
 - All parts must have their edges polished smooth before installation to avoid cracking in service.
-
1. Rivet Fuel Selector Sub-Panel in place.
 2. Attach Fuel Shut-Off Valve to Fuel Selector Sub-Panel.
 3. Determine orientation of fuel fittings in Shut-Off Valve and install.
 4. Install Bulkhead Fitting through Firewall.
 5. Route fuel lines to firewall and to wing fittings.
 6. Secure all lines with Stand-offs and Anti-Chaffe as needed.

FLAP HANDLE INSTALLATION

- Fuselage assembly must be performed on a flat work surface. Assembly on a warped surface will result in a warped fuselage
 - Wipe all parts down with acetone to remove markings before assembly
 - All parts must have their edges polished smooth before installation to avoid cracking in service.
1. Become familiar with the flap handle installation **Parts Drawings** and collect the parts shown in the drawings.
 2. Cleco Flap Mechanism Reinforcement Plates (KPFL0146) to the Inner Seat Ribs. Cleco Rear Spar Attach Plate (KPFU0408) to the Rear Spar Bulkhead.
 3. Modify 2 Hummertangs per **FIGURE 08B-03**. Bolt Flap Mechanism Weldment, Hummertangs, and Guide Plates in place. **NOTE:** *Forward mounting holes of Guide plates will need to be transfer drilled 1/4"*.
 4. Assemble Bearing Blocks with plain nuts to hold the halves together.
 5. Remove any coating from Flap Torque Tubes in the locations where the Bearing Blocks contact the Torque Tube.
 6. Using a rotary tool with a 1/2" drum sander attachment, open up the hole until the Torque Tube moves freely.
 7. Install Flap Torque Tube using hardware shown in the **Parts Drawing**.
 8. Assemble Flap Release Tube per **FIGURE 08B-08**. Press 3/4" Endcaps into both ends of Flap Release Tube.
 9. Slip Spring into Torque Tube handle. Slip Release Tube in after the Spring. Align 1/4" hole with slot in handle. Press Spacer bushing into place until centered in the handle. If necessary remove handle and ream until bushing can be pressed in.
 10. Depress Release Tube and slide Roller Bushings over each end of the Spacer Bushing. Install bolt with washers. **NOTE:** *Do **NOT** tighten nut too much. The Roller Bushings must be allowed to rotate.*
 11. Check operation by depressing the Release Tube. The Roller Bushing should engage fully into each notch of the Guide Plates.
 12. If the Roller Bushings do not engage fully, use a rat-tail file and modify the Guide Plates or slot in the Flap Handle if required to obtain smooth operation with full engagement.

FLAP PUSH ROD FUSELAGE EXIT

- Fuselage assembly must be performed on a flat work surface. Assembly on a warped surface will result in a warped fuselage
- Wipe all parts down with acetone to remove markings before assembly
- All parts must have their edges polished smooth before installation to avoid cracking in service.

NOTE: *This step will require the Wings with Flaps to be attached to the Fuselage. Waiting until Final Assembly is preferred.*

13. Place masking tape on fuselage at and around the exit point for the Flap Push Rod.
14. Place a bolt in the rod end attachment point on the Flap and move the Flap to the "UP" position.
15. Mark the point where the bolt contacts the Fuselage.
16. Drill to 5/8" using a Unibit. Open the hole until the Push Rod Assembly can be connected to both the Flap and the Flap Torque Tube. **NOTE:** *This hole should be at the bottom of the Fuselage Side Skin.*
17. Operate the Flap Mechanism until the Push Rod contacts the Fuselage. Mark this point, and remove material. Repeat until the Flap is operable through the entire range.
18. Flap rigging will be done in Final Assembly.
19. Polish the edges and final install the hardware.

TRIM SERVO INSTALLATION

- Fuselage assembly must be performed on a flat work surface. Assembly on a warped surface will result in a warped fuselage
 - Wipe all parts down with acetone to remove markings before assembly
 - All parts must have their edges polished smooth before installation to avoid cracking in service.
1. Become familiar with the Trim Servo installation **Parts Drawings** and collect the parts shown in the drawings.
 2. Draw a line per **FIGURE 08C-02** on the Stabilator Attach Angle. Cleco Servo to indicated hole. Align bottom right servo mounting hole with the drawn line. Mark and transfer drill #30. Remove Servo.
 3. Cut bushings to length from Raw Stock.
 4. Bolt Trim Servo Mount to Trim Servo.
 5. Bolt Servo, with bushings, through the 2 holes in the Stabilator Attach Angle.
 6. Align the holes in the flange of the Servo Mount with the centerline of the Bulkhead Reinforcement Gusset. Transfer drill #30 and rivet.
 7. Assemble the Trim Servo Push Rod with the Clevises (supplied with Servo Kit).
 8. Orientate the horn (the horn which attaches to the Servo) of the Trim Torque Tube forward and 90-degrees to Bulkhead #5.
 9. Set the Trim Servo Push Rod to length. **IMPORTANT:** *The Servo should be centered in its travel.*
 10. Assemble Trim Tab Push-Pull Tube (KPTR0061 & KPTR0062) with Loctite and plain nut. Set to length per **FIGURE 08C-10**. Attach Trim Tab Push-Pull Tube to Torque Tube and Trim Tab Horn.

OPTIONAL FUSELAGE VENTILATION SYSTEM

- All aluminum parts must have their edges polished smooth before installation to avoid cracking in service.

NOTE: *Vent Opening may be cut into the Forward Fuselage Side Skin (KPFU0643) before or after Fuselage Assembly.*

IMPORTANT: *The Vent template is only for use with the VANS Aircraft VENT SV-1. Order “VENT SV-COMBO X2” directly from VANS Aircraft.*

1. Become familiar with the Optional Ventilation System Installation **Parts Drawings** and collect the parts shown in the drawing.
2. Glue the template; **FIGURE 08D-02** to poster board. Do **NOT** cut out the vent opening in the template at this time.
3. Locate template on Forward Fuselage Side Skin (KPFU0643) per **FIGURE 08D-03**. Mark center of 1/4” and rivet hole locations on Fuselage. Remove template. Drill all marked holes #40. Drill vent opening edge holes 1/4”.
4. Cut out center opening of template. Re-cleco template to Fuselage and mark opening. Trim opening with a Dremel tool.
5. Place template on face of NACA Vent, mark the 3 rivet hole locations. Drill only the front hole to #40.
6. Cleco NACA Vent to the inside of the Fuselage Skin, align and transfer drill #40 the remaining aft holes. Final size #30.
7. Apply Silicone Seal to face of NACA Vent. Cleco to inside of Fuselage and rivet. Allow Silicone Seal to dry.
8. Locate position in or below panel for the “eyeball” vents. Cut opening, mount and secure.
9. Connect ducting.

OPTIONAL AVIONICS HEAT EXHAUST FAN INSTALLATION

- All aluminum parts must have their edges polished smooth before installation to avoid cracking in service.

NOTE: *Fan opening is pre-cut in Deck Skin.*

1. Become familiar with the Optional Avionics Heat Exhaust Fan installation **Parts Drawings** and collect the parts shown in the drawing.
2. Drill corner mounting holes of fan to #11.
3. Insert Brass Flange Nuts into mounting holes from the bottom of mount flange.
4. Place Screen over Fan. Locate mounting holes under screen and punch holes for the mounting screws.
5. Drill the 4 mounting holes in the Deck Skin to #28. Deburr.
6. Install Fan with Screen under Deck Skin.

09 - MAIN & NOSE GEAR

MAIN GEAR ASSEMBLY	09-1
MAIN GEAR WHEEL/BRAKE INSTALLATION	09A-1
NOSE GEAR INSTALLATION.....	09B-1
OPTIONAL MAIN WHEEL PANTS INSTALLATION.....	09C-1
OPTIONAL NOSE WHEEL PANT INSTALLATION.....	09D-1
OPTIONAL BELLY FAIRING INSTALLATION.....	09E-1
OPTIONAL TOW BAR WITHOUT WHEEL PANT INSTALLATION	09F-1

MAIN & NOSE GEAR

MAIN GEAR ASSEMBLY

- Sturdy sawhorses are required for landing gear assembly.
 - Wipe all parts down with acetone to remove markings before assembly
 - All parts must have their edges polished smooth before installation to avoid cracking in service.
1. Become familiar with the Main Gear Installation **Parts Drawings** and collect the parts shown in the drawings.
 2. Examine your Gear Legs and polish out any significant scratches or imperfections.
 3. Support the fuselage on sturdy sawhorses
 4. Pin the landing gear in place using the hardware shown in the **Parts Drawings**.
 5. Mark the location on the Gear Leg that extends through the Gear Block.
 6. Using a fine-tooth file, work the area that intersects the Gear Block flat so that the Gear Block applies even pressure to the surface of the Gear Leg. See **FIGURE 09-06**.
 7. Do the same to the lower surface where the Gear Attach Bar (KPMG0187) intersects the Gear Legs.
 8. Make sure all surfaces that make contact at the Gear Blocks are polished smooth. **NOTE: Be sure all file marks are removed from the Gear Leg and are *POLISHED SMOOTH* before installation.**
 9. Radius the outboard edges of the Gear Attach Clamps (KPMG0186) and the inside edges of the Gear Blocks per **FIGURES 09-09 and 09-09A**.
 10. It is recommended to paint the Gear Legs and Clamp Plates.

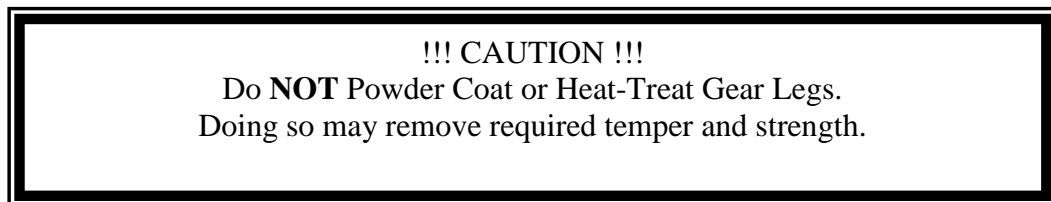

11. Install the landing gear using the hardware shown in the **Parts Drawings**.

12. If any movement is evident where the Gear Blocks intersects the Gear Legs, use a file to remove material between the Gear Blocks and Gear Attach Bars until the movement is eliminated. Refer back to **FIGURE 09-06**.

MAIN GEAR WHEEL/BRAKE INSTALLATION

- Wipe all parts down with acetone to remove markings before assembly
 - All parts must have their edges polished smooth before installation to avoid cracking in service.
1. Become familiar with the Main Gear Wheel/Brake Installation **Parts Drawings** and collect the parts shown in the drawings.
 2. Bolt caliper mount, fairing mount bracket and axle to the gear leg assembly as per parts drawing. Assemble the wheel and brake kit as per parts manual and manufacturer's instructions. With the aircraft in a level attitude the brake assembly will be orientated to the aft. **CAUTION:** *Be sure to safety wire the bolts holding the brake disk.* The tire pressure should be approximate 25 psi. To install the wheel assembly, the outer brake pad removes via the 1/4" retainer bolts. Loctite and safety wire these bolts in final assembly.
 3. Clean and pack the tapered wheel bearings. The tapered roller bearings are oiled from the factory for rust prevention, but not greased. The roller bearings should be cleaned, dried, and then packed with suitable grease. Packing grease without first removing the oil will dilute the wheel grease, causing it to run out past the seal and not lubricate properly.
 4. Slip the bearings and wheel / tire assembly back onto the axle. Install the washer and castle nut. Tighten the castle nut to manufactures specifications or bearing failure may result. Secure with the large cotter pin.

IMPORTANT INFORMATION: MATCO mfg wheels using tapered roller bearings are equipped with Timken bearings utilizing integrated grease seals on the bearing cone to ensure the longest possible life. The torqueing procedure for bearings with these type seals is different than for tapered roller bearings without them. A common torqueing technique for bearings *without integrated seals* is to tighten the axle nut until the wheel stops spinning freely and then back off to the nearest locking feature. **THIS TECHNIQUE WILL NOT WORK ON A BEARING WITH AN INTEGRATED SEAL.** The reason for a different torqueing technique is that the grease seal produces some drag and makes the wheel feel somewhat stiff when rotated. Reducing the axle nut torque until the wheel spins freely will allow the grease seal and the bearing cone to improperly rotate with the wheel (the cone must not rotate relative to the axle). The higher rolling drag is completely normal for this bearing and allows for longer bearing life since the seal will keep most contaminants out. Timken specification state, for example, that the two 1.25 inch tapered roller bearing used on the WE51 will produce 18-26 inch pounds of torque (drag) when properly installed. A light coating of grease on the seal will help reduce the drag on initial installation. The drag will also reduce after the bearings have been installed and the seal relaxes in the bore. It is important that the axle nut torque be sufficient to keep the seal

from rotating with the wheel. With the bearings cleaned, dried, greased, and inserted in the wheel, the axle nut should be tightened until all play is out of the assembly. Rotate the wheel back and forth while tightening the nut to help seat the bearings. When all play is out of the assembly, and the wheel rotates freely, tighten to the next castle slot and insert the cotter pin. The rubber seal on the tapered roller bearing will remain stationary while the wheel rotates around it. If the seal is spinning on the axle, the nut should be tightened further until the seal stops spinning with the wheel.

5. Wrap Teflon tape on the threads of the brake fitting and install the fitting into the caliper. The fitting should face upward.
6. Route the brake line from the Fuselage, down the Gear Leg, to the Brake Assembly. **NOTE:** *The brake line will press into the groove machined into the Gear Leg.*
7. Connect brake line to the fitting on the brake caliper.

NOSE GEAR INSTALLATION

- Wipe all parts down with acetone to remove markings before assembly
 - All parts must have their edges polished smooth before installation to avoid cracking in service.
1. Become familiar with the Nose Gear Installation **Parts Drawings** and collect the parts shown in the drawings.
 2. Support the fuselage on sawhorses and bolt the Nose Gear Mount to the firewall.
 3. Slide the Nose Gear into the Nose Gear Socket. Use a rotary file to remove excess coating in the Nose Gear Socket. **CAUTION: Do NOT remove excessive material. The Nose Gear must fit tight in the Socket.**
 4. Mark a ring 3/8" from the top end of the Nose Gear.
 5. Insert the Nose Gear into the Gear Leg Socket until the line is visible in the hole. **NOTE: To verify that the Nose Gear is in the correct position, measure the distance from the end of the Nose Gear to the upper edge of the Gear Socket. This should be about 1/4". See FIGURE 09B-05.**
 6. Rotate the Nose Gear until it is 90-degrees from the Spar Carry-thru on the Fuselage.
 7. It may be desirable to build a fixture to hold the gear leg in place. See **FIGURE 09B-07.**
 8. Transfer drill #11 the Nose Gear through the Gear Socket hole just deep enough to mark the Nose Gear.
 9. Remove the Nose Gear. Drill #11 using a "V-block" in a drill press to center the Nose Gear when drilling.
 10. Transfer drill "Letter D" through one side of the Nose Gear Collar. Refer back to **FIGURE 09B-05.**
 11. Slip Nose Gear Collar onto lower end of Nose Gear. Align holes and transfer drill "Letter D" through the other side of the Upper Fork Collar.
 12. Ream to 0.249" and bolt in place. **NOTE: If using a fixture to lock the leg for drilling leave the Collar off till drilling is complete.**
 13. Re-install the Nose Gear in the Gear Socket and fixture. Transfer drill through #11.
 14. Chase drill 6.2mm, then ream to 0.249". Bolt in place.
 15. Seat the Spring Washers by sanding on a sheet of 400-grit sandpaper. Refer to **FIGURE 09B-15.** This will help prevent premature wearing of the Spring Washers.

16. **IMPORTANT:** Before installing the Nose Gear Fork to the Nose Gear Strut inspect the Fork for stress risers. This is a high stress part and it is critical to remove any scratches on the surfaces of the Fork. The most critical is the bottom surface where any stress riser could result in eventual failure of the part. Be aware of this during annual inspections also, since the Fork is subjected to possible abuse. If you encounter gouges or scratches you can not use standard sanding and polishing techniques to remove, the Fork will need to be replaced. Sand and Polish the bottom of the Fork in parallel to the Fork blades. **CAUTION: DO NOT CROSS SAND the Fork blades.** Install the Nose Gear Fork according to the **Parts Drawings** and **FIGURE 09B-16**.
17. Using a fish scale, adjust the nut until the required pull is attained at the Axle Attachment on the Fork to move it. See **FIGURE 09B-17**.
18. Drill the Nose Gear #30 from each side for the cotter pin and install.
19. Temporarily assemble Nose Wheel Hub without Tire. Slide Axle through hub bearings. If the Axle will not slide into the wheel bearings, spin sand the Axle on a belt or disc sander. **IMPORTANT: Do NOT remove any more material than necessary.**
20. Cut the Spacer Bushing into 2 equal lengths. Install the Axle with the Bushings on each side. **NOTE: The Bushing material is provided long to allow trimming as needed.** One end of each Bushing will need to be profiled where they contact the Upper and Lower Nose Gear Attach fittings. Refer to **FIGURE 09B-20**.
21. Cut the Bushings to length so as to center the Wheel Hub in the Fork. **HINT: Add the measurements on each side of the Wheel Hub together. Divide by 2 to obtain equal lengths of the finished Bushings to center the Hub.** **IMPORTANT: The Bushings must be tight to allow no side to side play of the wheel.**
22. Remove Axle and Wheel Hub. Disassemble Hub and install Tire and Tube. Re-assemble with Tire & Tube.

OPTIONAL MAIN WHEEL PANTS INSTALLATION

1. Become familiar with the Optional Main Wheel Pants Installation **Parts Drawings** and collect the parts shown in the drawings.
2. Remove main gear axle and brake assembly. Install Inboard Wheel Pant Bracket to inboard side of Gear Leg. **NOTE:** *Remove the 1/4" thick washers from under the heads of the axle attachment bolts.*
3. Drill and tap axle as shown in **FIGURE 09C-03**. **IMPORTANT:** *When tapping the axle, start with a tapered tap and finish with a bottoming tap. Use tap cutting oil for best results. Reinstall axle and brake assembly.*
4. Level the airframe to a reading of 0.0° at the top of the Forward Longeron.
5. Temporarily install Wheel Pant Axle Bracket to axle. Position Axle Bracket 90° vertical.
6. Bulkheads are pre-installed in Main Wheel Pants and should not require additional fiberglass work.
7. Fabricate a 1.25-inch spacer block per **FIGURE 09C-07**. Use the spacer block to set the height of the AFT Main Wheel Pant. **NOTE:** *The Aft Main Wheel Pant will install with centerline in the vertical position, not with the center line of the tire. Refer to **FIGURE 09C-07A**. The tire opening in the wheel pant will remain relatively centered at the bottom.*
8. Use a 6" wood block to support the aft tip of the AFT Main Wheel Pant. See **FIGURE 09C-08**.
9. To position the Main Wheel Pant centerline seam parallel to the Fuselage centerline, place a straight edge across the aft sides of the gear blocks on the belly of the fuselage. Use a framing square to position the aft tip of the pant. **NOTE:** *A sand bag may be needed to prevent the pant from slipping off the 6" wooden block. Making reference marks on the floor and wooden block may be helpful. See **FIGURE 09C-09**.*
10. Trimming of the tire opening will be needed as the Aft Main Wheel Pant is slid on from the rear. Position the Aft Main Wheel Pant so the joggle overlaps the Wheel Pant Axle Bracket. The bent angles on the Axle Bracket may need to be relaxed to allow the Aft Main Wheel Pant to slip over. The Axle Bracket should be bent so as not to distort the normal shape of the pant. As the Aft Main Wheel Pant is slid into its final position, trimming of the joggle will be necessary to provide clearance for the gear leg. See **FIGURE 09C-10**. **IMPORTANT:** *When final positioning the pant ensure clearance between the inside of the pant and the lower bolt head on the caliper. A 3/16" minimum gap is desired. The bent angles on the Inboard Wheel Pant Bracket may be increased or decreased to achieve the proper clearance. **IMPORTANT:** *Contact of the Main Wheel Pant against the brake caliper will cause the brake pad to rub on the brake disk in the open position causing brake drag and increased brake pad wear.**

11. Position the AFT Main Wheel Pant in the correct position. Drill #30 through the outboard side of pant at the rivet locations on the Wheel Pant Axle Bracket. Cleco in place. Use a hole-finder as required.
12. Drill #40 through the inboard side of pant at the 2 screw hole locations on the aft half of the Inboard Wheel Pant Bracket. Cleco in place. Use a hole-finder as required.
13. Counter sink and rivet Aft Main Wheel Pant to Wheel Pant Axle Bracket.
14. Remove Aft Main Wheel Pant. Slide Aft and Fwd Main Wheel Pants together. Line up center-line seams and transfer marks for the Gear Leg cut-out and tire opening onto the Fwd Main Wheel Pant. **NOTE:** *This process will be helpful for finding a starting point for trimming of the Fwd Main Wheel Pant as it is slid into position.*
15. Reinstall the Aft Main Wheel Pant with clecos and support block in place. Trim the tire opening and gear leg clearance on the Fwd Main Wheel Pant as needed to join the FWD pant with the AFT pant. Secure the FWD pant to the AFT pant with tape.
16. Take a drop down measurement from the FWD tip of the FWD pant and a drop down measurement from the center of the AFT tip on the AFT pant. With AFT pant temporarily installed with undersized clecos pitch the Wheel pant up or down to achieve the same drop down measurements at the FWD and AFT tips of the pants. Refer back to **FIGURE 09C-08**.
17. Drill through the inboard side of the FWD pant into the two screw locations on the FWD half of the Inboard Wheel Pant Bracket. Cleco in place. **NOTE:** *A template taped to the inboard AFT pant may be used to locate the two screw holes in the FWD half of the Inboard Wheel Pant Bracket. See **FIGURE 09C-17**.*
18. With both pants clecoed and taped in position drill six holes #40 through the joggle area and cleco as shown in **FIGURE 09C-18**. Final size holes to #11. Remove pants and install nut plates on the inside of the joggle on the AFT pant.
19. Install nut plates on the outboard side of the Inboard Wheel Pant Bracket. All mounting holes in pants should be countersunk to allow countersunk washers to seat flush.
20. Mark and cut a cooling opening on the inboard side of the Aft Main Wheel Pant. Use **FIGURE 09C-20** as a template.
21. Install pants with all countersunk washers and screws. Check for any final trimming. Tire opening on pants should have at least 1/2" clearance for tire. Gear leg cut out should have at least 3/16" clearance with the gear leg. **CAUTION:** *Tire pressure must be maintained to keep clearance between Wheel Pants and Tires. **IMPORTANT:** The weight of the wings will reduce the tire clearance if wings are installed after wheel pants are fit up.*
22. Remove Wheel Pants and paint as desired.
23. Install firesleeve on the brake line from the brake housing to the gear leg where the brake line enters the slot on the aft side. Secure with safety wire.

OPTIONAL NOSE WHEEL PANT INSTALLATION

1. Become familiar with the Optional Nose Wheel Pant Installation **Parts Drawings** and collect the parts shown in the drawings.
2. Rivet Nut Plates to inside of Wheel Pant Attach Angles (KPNG0092).
3. Modify Nose Gear Tow Plate per **FIGURE 09D-03**. Install Wheel Pant Attach Angles, Nose Gear Tow Plates and 1/4" Bolts as per parts page.
4. Drill #30 through 4 dimples (2 per side) on AFT Nose Wheel Pant (KPNG0095-1). Refer to **FIGURE 09D-04**.
5. Cut slots for Nose Gear Tow Plate on trim lines inscribed on the wheel pant. Slots will not need to be cut full length of the trim lines. Refer back to **FIGURE 09D-04**. Trim slots as needed to clear Nose Gear Tow Plate.
6. Trim tire opening an extra 1/4" around entire opening. Refer back to **FIGURE 09D-04**.
7. Slide AFT Pant on to Nose Gear Fork until nut plates are visible through dimple holes in the side of the pant. Clearance for the Nose Gear will need to be trimmed on the joggle of the Aft Pant at the top centerline position. To gain nose gear clearance on the FWD pant, cut on the scribe lines located at the top centerline position. Refer to **FIGURE 09D-07**.
8. When AFT pant is properly located final size dimple holes to # 11, counter sink and install 3/16" Countersunk Machine Screws and Countersunk Washers.
9. Install FWD Nose pant and secure with tape. Drill 6 holes along the joggle #40. See **FIGURE 09D-09**. Final size holes to #11.
10. Remove wheel pant and install nut plates on the inside of the AFT Nose pant joggle at each of the 6 hole locations.
11. Re-install AFT and FWD Nose pants. Counter sink the #11 holes in the FWD pant only enough to allow the Countersunk Washers to seat flush. Install Countersunk Machine Screws and Countersunk Washers.
12. Check for 1/8" clearance around Nose Gear in all positions. Trim as needed. **CAUTION:** *Tire pressure must be maintained to keep clearance between Wheel Pant and Tire.*
13. Remove Wheel Pant and paint as desired.

OPTIONAL BELLY FAIRING INSTALLATION

1. Become familiar with the Optional Belly Fairing Installation **Parts Drawings** and collect the parts shown in the drawings.
2. The Optional Belly Fairings are formed on a single sheet with both Right and Left hand parts.
3. Cut the Belly Fairings apart from each other.
4. Refer to **FIGURE 09E-04** and trim the perimeter of each part.
5. Position the Belly Fairing under the fuselage and mark for the gear leg. Trim the gear leg opening for best fit.
6. Locate and drill #11 holes through the Belly Fairing and through the fuselage belly. Refer back to **FIGURE 09E-04**. **CAUTION:** *Locate holes in Belly Fairing as necessary to miss Fuselage Ribs and Internal Superstructure.*
7. Slip Grommet into slot for Brake line. Attach foam to fuselage above outer flange of Belly Fairing.
8. Position and rivet nut plates inside the fuselage.
9. Remove Belly Fairing and paint as desired.

OPTIONAL TOW BAR WITHOUT WHEEL PANT INSTALLATION

1. Become familiar with the Optional Tow Bar without Wheel Pants Installation **Parts Drawings** and collect the parts shown in the drawings.
2. Modify Nose Gear Tow Plate per **FIGURE 09F-02**.
3. Install Nose Gear Tow Plates as per parts page.

12 - OPTIONAL INTERIOR

OPTIONAL INTERIOR INSTALLATION	12-1
OPTIONAL BAGGAGE CLOSEOUT INSTALLATION.....	12A-1

OPTIONAL INTERIOR

OPTIONAL INTERIOR INSTALLATION

1. Become familiar with the Optional Interior **Parts Drawings** and collect the parts shown in the drawing.
2. Refer to provided OPTIONAL INTERIOR DVD (KPIN0082) for installation.
3. Refer to **FIGURE 12-03** for placement of the VENTERRA logo fabric, provided with Cloth (KPIN0069) onto the Side Panel – Middle Insert (KPIN0065). RANS uses **3M™ Super 77™ Multipurpose Adhesive**. Be sure the fabric with VENTERRA logo is positioned correctly before gluing. Refer to **FIGURE 12-03A**. ***HINT:** Wrap fabric to the back side of the insert and cut “darts” (small angle cuts) where the fabric laps over itself to allow the fabric to lay flat.*

OPTIONAL BAGGAGE CLOSEOUT INSTALLATION

1. Baggage Closeout may not be fit-up until the Tailcone is assembled and mated to the Fuselage Center Section.
2. Locate holes for nut plates in Bulkhead #1. Refer to **PARTS PAGES** for reference. Drill the center hole #11 and deburr. Rivet nut plates in place.
3. Fabricate 6 Marking Pins from scrap 8-32 screws or bolts. See **FIGURE 12A-03**. These pins will be used to mark the hole locations onto the aft side of the Baggage Closeout.
4. Trim the edges of the Baggage Closeout till it fits easily against #1 Bulkhead.
5. Remove Closeout and install the Marking Pins into the nut plates. Install Closeout and use a small board to press against the Marking Pins.
6. Remove closeout and step drill to #11 at the pin marks.
7. Remove Marking Pins and install the Baggage Closeout during final assembly

15 - PREPARATION FOR FLIGHT

INTRODUCTION.....	15-1
CONTROL SURFACE RIGGING	15-1
RUDDER:.....	15-1
STABILATOR:.....	15-1
ANTI-SERVO / TRIM TAB:.....	15-1
FLAPS:.....	15-1
AILERONS:	15-2
FLUIDS	15-2
OIL:.....	15-2
COOLANT:.....	15-2
BRAKE:	15-2
FUEL:	15-2
INSPECTION	15-3
RUNUP	15-3
DESIGNATED AIRWORTHINESS REPRESENTATIVE	15-4
FIRST FLIGHT	15-4

PREPARATION FOR FLIGHT

INTRODUCTION

OK, you've built an airplane. It's sitting on the hanger floor before you in all of its majestic glory. What next? At this point you need to ignore your enthusiasm and slow down. If you set yourself a date for the first flight, forget about it. This is the most critical part of your project. Mistakes and skipped steps here can be both costly and fatal.

CONTROL SURFACE RIGGING

The rudder is fairly self explanatory. Center the pedals, center the rudder, done. The ailerons are not as easy, but not too bad either. Don't rush this step and make sure you Loctite all your jam nuts as you go.

- 1. RUDDER:**
The rudder adjustment is built into the cables. One end has three holes in a straight line. These are for rough adjustment and are located at the forward end of the cables. The fine adjustment is at the rear of the cable. Here you will find 4 staggered holes. Adjust the forward end first, and make your fine adjustments last. See **FIGURE 15-01**. No stops need to be set; they are built into the control horns.
- 2. STABILATOR:**
Refer to **FIGURE 15-02**. Push-pull tubes were set to length during Fuselage assembly. Refer back to Fuselage Figure Drawing Manual if needed to verify. Pin the Bell Crank Assembly, behind the baggage area, in position. Fine adjust the Forward Push-Pull Tube until the Control Sticks are perpendicular (90 deg) to the Forward Longeron. Fine adjust the Aft Push-Pull Tube until the Stabilator is level (0 deg) to the Forward Longeron. Leveling the Stabilator may be aided by fabricating a Stabilator Leveling Jig. Refer to **FIGURES 15-02A** thru **15-02F** for details. Remove the pin. Adjust and lock the Stop Bolts on the Control Stick Torque Tube to obtain the travel shown. See **FIGURE 15-02**.
- 3. ANTI-SERVO / TRIM TAB:**
With Stabilator adjusted and locked as in preceding step. Verify Trim Servo to be in the center of its travel. Check that the orientation of the horn, which attaches to the Servo, of the Trim Torque Tube is forward and 90-degrees to Bulkhead #5. Adjust Trim Tab Push Pull Tube to align Anti-Servo / Trim Tab with trailing edge of Stabilator. Verify that Trim Indicator is within "Take-off" position. Remove locking pin.
- 4. FLAPS:**
Set Flap Handle to lowest position. Adjust each Flap Push Rod until the bottom of each flap is level with the bottom of the wing. See **FIGURE 15-04**.

5. AILERONS:

Refer to **FIGURE 15-05**. Push-pull tubes were set to length during Wing assembly. Refer back to Wing Figure Drawing Manual if needed to verify. Pin the Outer Aileron Bell Cranks. Fine adjust the Push-pull tubes until Control Sticks are perpendicular (90 deg) to the Spar Carry-thru. Adjust bottoms of the ailerons level with the bottoms of the wings. Remove the pins. Adjust and lock the Stop Bolts to obtain the travel shown on **FIGURE 15-05**.

FLUIDS**OIL:**

Fill the bottle and cooler and prime the engine by spinning the engine over with the starter until oil pressure is present. **NOTE:** *Do this with the lower spark plugs removed.*

COOLANT:

Fill the cooling system at the expansion bottle on the top of the engine. Burp the system by squeezing the hoses. Most of the air should be purged to the expansion bottle this way. Refill the bottle and replace the cap. Fill the coolant reservoir half way. **NOTE:** *Squeeze a hose to apply some pressure to the system and check for leaks.*

BRAKE:

This is the part of final assembly that causes the most stress. This is due mainly to brake fluid's ability to hold microscopic bubbles in suspension. This usually causes the procedure to be repeated more than once. You do have an advantage; you have clear brake lines and can see the bubbles. In our experience, we have found that it is easier to push the bubbles up-hill to the reservoir than to try to pump them down-hill using the cylinders. To accomplish this we use a clean pump type oil can. (The kind that has an internal piston pump that is driven by a lever over the handle) We fasten a 1/8" tube to the end of the spout and slide the other end over the brake bleed valve on the caliper. Open the valve, remove the reservoir cap, and pump the fluid into the system. Stop when you have fluid just past the cylinders and approaching the reservoir. Wait a few hours for the bubbles to settle out and push some more fluid up to the reservoir. If you get lucky you won't have to remove any fluid from the reservoir. **IMPORTANT:** *Be sure you have used the correct type of brake fluid.*

FUEL:

Fill a gallon a side and check for leaks. Repeat until full. Check with your fuel gauge manufacturer as this may be a good time to calibrate the sender.

INSPECTION

Follow the checklist in the appendices and verify every nut, bolt, washer, cotter pin, etc. In fact, double and triple check just to be sure.

RUNUP

Look again at your fluid levels, verify that your Ignition Switches are grounded, and have continuity to the leads on the engine.

Check the throttle arrangement; verify that it is in the “**IDLE**” position.

Turn the prop over by hand a few times to verify that there is no fluid in the cylinders and to prevent hydro lock.

Get out your ROTAX owners manual and verify that you have complied with everything.

Tie the airplane down in a clear area, lock open the canopy, remove the cowlings, and chock the wheels. Plan a route in case it pulls loose from the tie downs.

Get a friend to observe the run-up and man a fire extinguisher.

Buckle yourself in.

Verify the locations of critical valves and switches. (Starter, Main fuel valve, Fuel pump, Master, Mags)

Clear the area. Start and run in accordance with the instructions in the ROTAX owner's manual. (**Check oil pressure immediately on start up**) If there is no immediate oil pressure, turn the engine off.

Bring the engine up to operating temperatures. You may not be able to accomplish this at idle.

Turn off the engine and allow to cool. Check for leaks and repair if needed. Check all fluid levels and top-off as needed.

Repeat run-up and repair until satisfactory results are obtained.

DESIGNATED AIRWORTHINESS REPRESENTATIVE

Present the airplane to the Designated Airworthiness Representative (DAR) in ready to fly condition. Be sure your weight and balance documentation is complete and ready to present to the DAR. Be ready to answer any questions about the building of the airplane. If you have documentation of building your airplane, present this to the DAR. It may prevent a game of 20 questions. A list of DAR's by region is available on the FAA website.

FIRST FLIGHT

Now is the time to search your soul and decide if being a test pilot is right for you. Are your skills sharp enough to save you from unexpected flight issues? Have you studied and familiarized yourself with the Operations Manual for the S-19 VENTERRA?

There are pilots that specialize in first flights and flight testing, and can be hired to do this for you. Some also give instruction in your airplane after the testing is complete.

16 - WEIGHT AND BALANCE

INTRODUCTION.....	16-1
AIRCRAFT WEIGHING PROCEDURES	16-1
CALCULATING CENTER OF GRAVITY	16-2

WEIGHT AND BALANCE

INTRODUCTION

This section describes the proper procedures for determining the weight and balance of the S-19 Venterra.

Always check your weight and balance during your preflight planning. It is recommended to check the data for landing and take-off due to fuel burn weight change.

It is the responsibility of the pilot to ensure that the aircraft is loaded properly.

AIRCRAFT WEIGHING PROCEDURES

1. Preparation:
 - Inflate tires to recommended operating pressure
 - Drain all fuel
 - Service engine oil as required to obtain a normal indication
 - Service engine coolant as required to obtain a normal indication
 - Retract flaps
 - Place all control surfaces in neutral position

2. Leveling:
 - Shim scales to level Upper Longeron. Place scales under each wheel (400 lbs. minimum capacity)

3. Weighing:
 - With the aircraft level, record the weight shown on each scale.

CALCULATING CENTER OF GRAVITY

The following will enable you to determine the weight and balance of your aircraft and to operate it within the prescribed center of gravity limitations.

The S-19 Venterra is a simple aircraft, and so are the weight and balance calculations.

The aircraft is limited to 2 occupants.

For baggage storage a baggage compartment behind the seats is available. The compartment is rated for 70 lbs. Baggage should be secured in flight.

Enter the following data on the chart. Refer to **FIGURE 16-01**.

- Weight of Nose Gear.
- Weight of Main Gear – Left.
- Weight of Main Gear - Right.
- Weight of Pilot.
- Weight of Passenger.
- Usable Fuel (at 6 lbs. / gal).
- Weight of Baggage (Max 70 pounds).

Calculate the moments (Weight x Arm).

Add moments to obtain total moment.

Add weights to obtain total weight.

Calculate Center of Gravity. (**CG = Total Moment / Total Weight**)

Check that the Center of Gravity calculated for take-off falls inside of the acceptable Center of Gravity envelope.

Repeat for landing configuration.

RANS

S-19 VENTERRA

OPERATIONS MANUAL

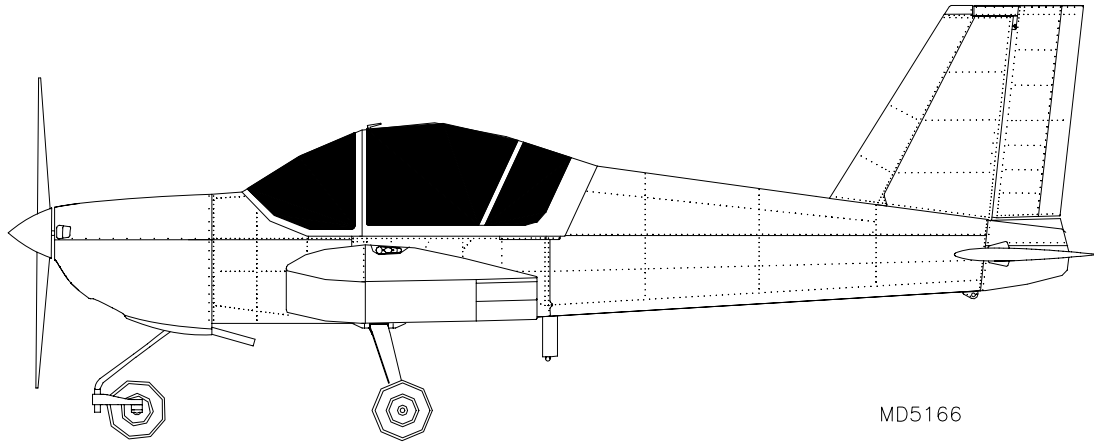

MD5166

Serial Number:

Registration Number:

COPYRIGHT ©

RANS DESIGNS
4600 HWY 183 Alt
HAYS, KANSAS, USA 67601
785-625-6346
www.rans.com

TABLE OF CONTENTS

	Page
Three View	17-5
General information	17-6
Entering and Exiting Aircraft	17-6
Canopy	17-7
Canopy Open Flight	17-7
Operating Limitations	17A-1
Airspeed Limitations	17A-1
Maximum Demonstrated Crosswind Velocity	17A-1
Weight Limits	17A-2
Center Of Gravity Limits	17A-2
Maneuver Limits	17A-2
Flight Load Factor Limits	17A-2
Flight Conditions Operation Limits	17A-2
Fuel Limitations	17A-3
Other Limitations	17A-3
Weight and Balance Information	17B-1
Aircraft Weighing Procedures	17B-1
Weight and Balance	17B-4
Emergency Procedures	17C-1
Airspeeds for Emergency Operation	17C-1
Operational Checklists	17C-2
Engine Failure	17C-2
Forced Landings	17C-3
Landing With a Defective Main Wheel Tire	17C-4
Fires	17C-4
Amplified Procedures	17C-6
Engine Failure	17C-6
Forced Landing	17C-7

Recovery From A Spiral Dive	17C-7
Spins	17C-7
Rough Engine Operation	17C-8
Normal Procedures	17D-1
Airspeeds for Normal Operation	17D-1
Operational Checklists	17D-2
Preflight Inspection	17D-2
Before Starting the Powerplant	17D-5
Starting the Powerplant	17D-5
Taxiing	17D-6
Before Takeoff	17D-6
Takeoff	17D-6
Enroute Climb	17D-7
Cruise	17D-7
Approach	17D-7
Before Landing	17D-7
Landing	17D-8
After landing	17D-8
Securing the Aircraft	17D-8
Amplified Procedures	17D-9
Pre-flight Inspection	17D-9
Starting the ROTAX 912ULS Powerplant	17D-9
Taxiing	17D-10
Before Takeoff	17D-11
Takeoff	17D-12
Enroute Climb	17D-13
Cruise	17D-13
Stalls	17D-13
Approach	17D-13
Landing	17D-14
Hot Weather Operation	17D-14

Aircraft Ground Handling and Care	17E-1
Ground handling	17E-1
Tie Down Instructions	17E-1
Aircraft Care	17E-2
Windshield and Canopy	17E-2
Painted Surfaces	17E-2
Interior Care	17E-2
Required Placards and Markings	17F-1
Airspeed Indicator Markings	17F-1
Placards	17F-1
Supplementary Information	17G-1
Familiarization Flight Procedures	17G-1
Pilot Operating Advisories	17G-1

THREE VIEW

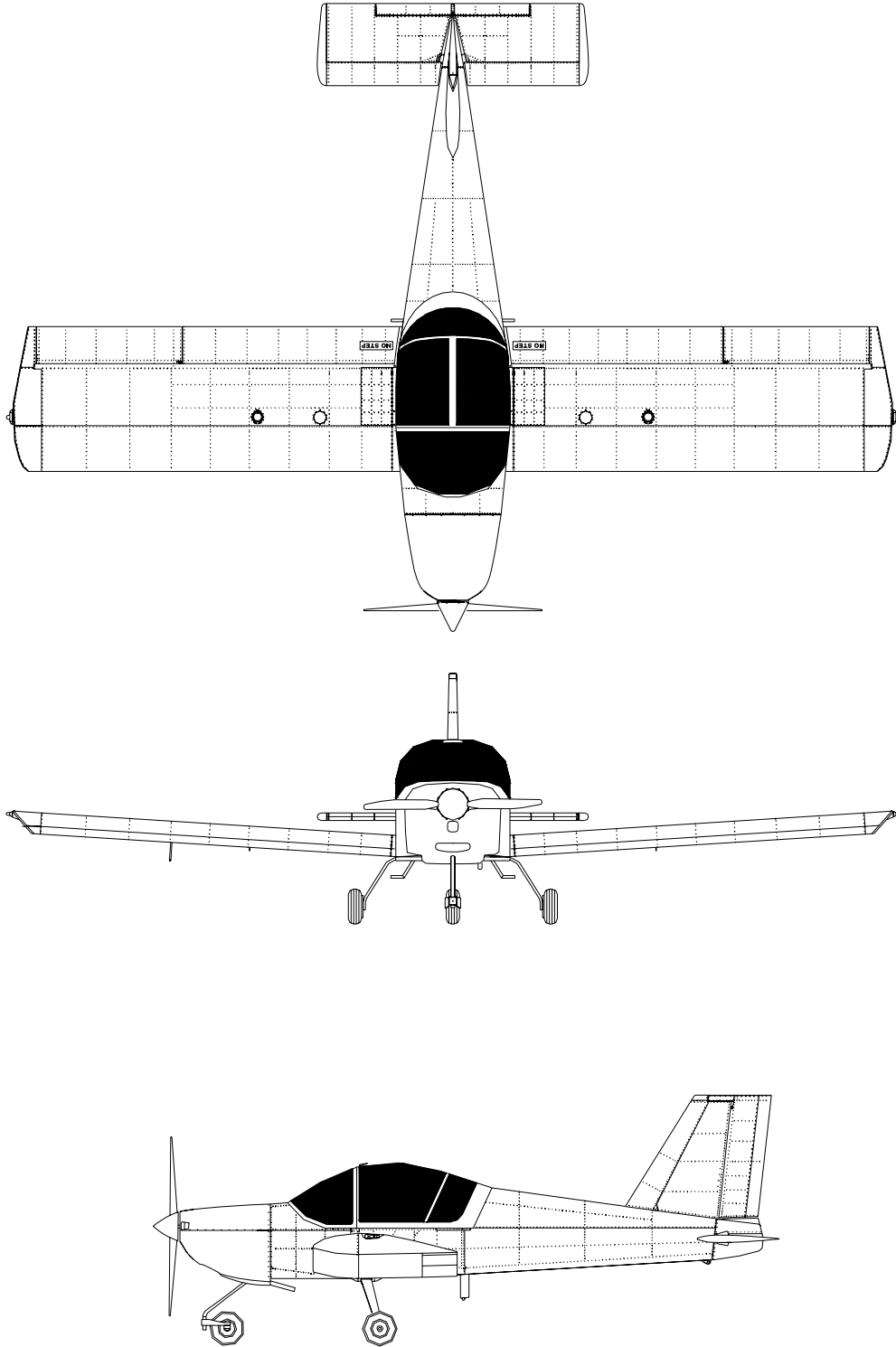

17 - GENERAL INFORMATION

This handbook contains sections 17 thru 17G.

Use this Operations Manual as a guide. Every aircraft is slightly different due to such factors as weight, equipment, paint finish and builder skills, just to name a few.

The pilot should study the entire Operations Manual to familiarize themselves with the limitations, performance, and procedures applicable for this aircraft.

ENTERING AND EXITING AIRCRAFT

To enter the S-19:

- Open the canopy by rotating the latch handle
- Slide canopy aft until past the canopy locks
- Flip the canopy locks into place
- Lower the flaps completely to gain access to the foot step
- Use the front edge of the canopy, once locks are in place as a hand hold
- Place the inside foot on the foot peg
- Lean forward, keeping weight over the rear spar
- Move up onto the wing
- Stand holding the roll bar
- Place both feet on the seat
- Hold the roll bar and lower onto seat
- Move legs into rudder pedal area
- Adjust and lock seat in position

CAUTION: *The S-19 is a light aircraft and it is easy to tip over onto the tail. To avoid this, enter with your body weight over the rear spar, do **NOT** stand straight up on the foot step; this will force the tail down. Weight in the baggage compartment, any tail low incline, or surface winds blowing on the tail will contribute to this tendency to rest on the tail.*

NOTE: *Seats should be aft for easy entry.*

Adjust seat position using roll bar support tube as a hand hold. See below for seat adjustment details.

To exit the S-19:

- Lower the flaps completely to gain access to the foot step
- Slide canopy aft until past the canopy locks
- Flip the canopy locks into place
- Move seat into aft position and lock
- Use the roll bar as a hand hold
- Stand up in the seat with both feet
- Step onto wing facing forward, use the canopy front as a hand hold
- Find foot step and step backwards off wing, keeping weight over rear spar

NOTE: *Seat should be aft for easy exit.*

CANOPY

The sliding canopy can open in flight if the latch is not secure. Due to aerodynamic pressure the canopy will only open between 1" or 2", and can easily be closed.

CAUTION: *If canopy opens in flight, continue to fly the plane, trim to hands-off level flight if possible, then close canopy.*

Canopy Open Flight

The canopy latch features a setting for canopy open flight. The front of the latch has a fish-mouth shape to allow it to rest against the latch pin on the roll bar and hold the canopy open about 1". This allows extra airflow into the cockpit and should be used only for brief periods if experiencing extra warmth within the cabin. To use this feature, trim aircraft for hands-off level flight, open latch, and pull canopy back enough to set the fish-mouth portion of the latch against the latch pin on the roll bar.

To close canopy: Trim aircraft for hands off level flight, pull canopy aft off the latch pin, and close normally.

17A - OPERATING LIMITATIONS

This section includes operating limitations, instrument markings, and basic placards necessary for the safe operation of the aircraft, power plant, and standard equipment.

The Rotax 912 ULS Operators Manual must be onboard of the aircraft.

AIRSPPEED LIMITATIONS

Airspeed limitations and their operational significance are shown in **Table 17A-1**. All speeds are given for maximum takeoff weight. Speed are given in MPH and (KNOTS)

	Airspeed	CAS	IAS	Remarks
VNE	Never Exceed Speed	150 (130)	143 (124)	Do not exceed this speed in any operation
VA	Maneuvering Speed at maximum gross weight	125 (109)	120 (104)*	Do not make full or abrupt control movements above this speed.
VFE	Maximum Flap Extended Speed	90 (78)	86 (75)	Do not exceed this speed with flaps extended.
VSO	Stall speed	45 (39)	47 (41)**	Flaps full down
VS	Stall speed	51 (44)	49 (43)**	Flaps up

TABLE 17A-1: AIRSPPEED LIMITATIONS

* At weights below maximum gross weight, maneuvering speed should be reduced 3 mph for each 50 lbs. the aircraft weighs below maximum gross weight.

** Power-off configuration

MAXIMUM DEMONSTRATED CROSSWIND VELOCITY

Takeoff23 MPH (20 Knots) @ 90 degrees
Landing.....23 MPH (20 Knots) @ 90 degrees

This is not considered limiting.

WEIGHT LIMITS

Maximum Ramp weight:1320 lbs.
 Maximum Takeoff weight:1320 lbs.
 Maximum Landing weight:1320 lbs.
 Maximum weight in Baggage compartment: 70 lbs.

CENTER OF GRAVITY LIMITS

Forward:83.0 inches aft of datum
 Aft:.....91.5 inches aft of datum
 Reference Datum: 72” forward of the wing leading edge.

MANEUVER LIMITS

This aircraft is intended for non – acrobatic operations.
 The angle of bank should not exceed 60 ° and the pitch attitude may not exceed 30 °.
 Stalls except whip stalls are approved with slow deceleration.

► Acrobatic maneuvers, including spins are not approved in the RANS S-19 VENTERRA aircraft.

FLIGHT LOAD FACTOR LIMITS

Flaps Up:..... + 4.4 g, - 2.0g
 Flaps Down: + 2.0 g, 0 g

FLIGHT CONDITIONS OPERATION LIMITS

Flight into known icing conditions is prohibited.

This aircraft is limited to two occupants only.

Night flights according to VFR, flights according to IFR (by instruments) are approved only when instrumentation required for such flights is installed and maintained according to applicable F.A.R.S. and flight performed by a pilot with applicable rating and currency!

Intentional flights into known icing conditions are prohibited.

FUEL LIMITATIONS

Approved Fuel Grades: Dependent on engine used

Fuel Capacity:

Total Capacity: 24 U.S. GAL

Total Capacity each Tank: 12 U.S. GAL

Total Usable: 22 U.S. GAL

Total Unusable: 2 U.S. GAL

Takeoffs have not been demonstrated with less than 2 gallons of total fuel (1 gallon per tank).

Fuel gauge accuracy is only accurate at the “**EMPTY**” reading for any type of gauge.

OTHER LIMITATIONS

Flap Limitations:

Approved Takeoff Range: retracted, 1/3 or 2/3 flaps (0° to 30°)

Approved Landing Range: retracted to full flaps (0° to 40°)

17B - WEIGHT AND BALANCE

INTRODUCTION

SECTION 16 of this manual has full information on WEIGHT and BALANCE. Information from the Weight and Balance calculations may be recorded in this section for your convenience.

This section describes the proper procedures for determining the weight and balance of the S-19 Venterra.

Always check your weight and balance during your preflight planning. It is recommended to check the data for landing and take-off due to fuel burn weight change.

It is the responsibility of the pilot to ensure that the aircraft is loaded properly.

AIRCRAFT WEIGHING PROCEDURES

1. Preparation:
 - Inflate tires to recommended operating pressure
 - Drain all fuel
 - Service engine oil as required to obtain a normal indication
 - Service engine coolant as required to obtain a normal indication
 - Retract flaps
 - Place all control surfaces in neutral position
2. Leveling:
 - Shim scales to level Upper Longeron. Place scales under each wheel (400 lbs. minimum capacity)
3. Weighing:
 - With the aircraft level, record the weight shown on each scale.

CALCULATING CENTER OF GRAVITY

The following will enable you to determine the weight and balance of your aircraft and to operate it within the prescribed center of gravity limitations.

The S-19 Venterra is a simple aircraft, and so are the weight and balance calculations.

The aircraft is limited to 2 occupants.

For baggage storage a baggage compartment behind the seats is available. The compartment is rated for 70 lbs. Baggage should be secured in flight.

Enter the following data on the chart. Refer to **FIGURE 17B-01** below. **SECTION 16** of the Text and Figures Manual has full instructions and a full page format chart for calculating Weight & Balance.

- Weight of Nose Gear.
- Weight of Main Gear – Left.
- Weight of Main Gear - Right.
- Weight of Pilot.
- Weight of Passenger.
- Usable Fuel (at 6 lbs. / gal).
- Weight of Baggage (Max 70 pounds).

Calculate the moments (Weight x Arm).

Add moments to obtain total moment.

Add weights to obtain total weight.

Calculate Center of Gravity. (**CG = Total Moment / Total Weight**)

Check that the Center of Gravity calculated for take off falls inside of the acceptable Center of Gravity envelope.

Repeat for landing configuration.

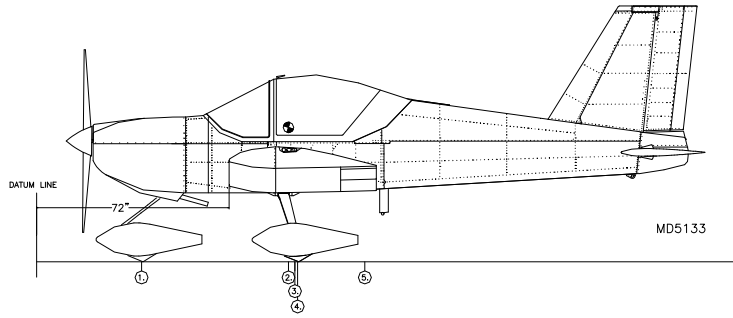

RANS S-19
WEIGHT AND BALANCE

N _____	
DATE WEIGHED	
ENGINE TYPE	
C.G. CONDITION	
EMPTY WEIGHT	
MTOW (912 ULS)	1320 LBS.

ACCEPTABLE C.G. 83" TO 91.5" FROM DATUM LINE.
DATUM LINE IS 72" AHEAD OF WINGS LEADING EDGE.

#	ITEM	WEIGHT	ARM	MOMENT
1	NOSE GEAR	147	39.3"	5777.1
2	PILOT	175	94.0"	16450
2	PASSENGER	140	94.0"	13160
3	FUEL	144	96.3"	13867.2
4	MAIN GEAR - RIGHT	347	97.6"	33867.2
4	MAIN GEAR - LEFT	345	97.6"	33672
5	BAGGAGE*	22	122.7"	2699.4
TOTAL =		1320	TOTAL =	119492.9

$$\frac{\text{TOTAL MOMENTS}}{\text{TOTAL WEIGHT}} = \text{C.G.} = \frac{119492.9}{1320} = 90.5"$$

#	ITEM	WEIGHT	ARM	MOMENT
1	NOSE GEAR		39.3"	
2	PILOT		94.0"	
2	PASSENGER		94.0"	
3	FUEL		96.3"	
4	MAIN GEAR - RIGHT		97.6"	
4	MAIN GEAR - LEFT		97.6"	
5	BAGGAGE*		122.7"	
TOTAL =			TOTAL =	

$$\frac{\text{TOTAL MOMENTS}}{\text{TOTAL WEIGHT}} = \text{C.G.} = \text{_____} =$$

* 70 POUNDS MAXIMUM BAGGAGE

FIGURE 17B-01 – WEIGHT AND BALANCE CHART

17C - EMERGENCY PROCEDURES

This section provides checklists and amplified procedures for coping with emergencies that may occur. Emergencies caused by aircraft or powerplant malfunctions are rare if proper preflight inspections and maintenance are performed. Emergencies caused by extreme weather situations can be minimized or eliminated by good judgment and proper preflight planning. However, should an emergency arise the basic guidelines described in this section should be considered and applied as necessary to resolve the problem.

In any emergency – FLY THE PLANE FIRST - maintain control.

AIRSPEEDS FOR EMERGENCY OPERATION - IAS MPH (Knots)

Engine Failure After Takeoff	Flaps UP	79 (69)
	Flaps DOWN	72 (63)
Maneuvering Speed		120 (104)
Maximum Glide	Flaps UP	83 (72)
Precautionary Landing with Engine Power	Flaps UP	72 (63)
	Flaps DOWN	65 (57)
Landing without Engine Power	Flaps UP	83 (72)
	Flaps Down	78 (68)

OPERATIONAL CHECKLISTS

ENGINE FAILURE

Engine Failure During Takeoff Run:

Fly the Aircraft!

- (1) Throttle - IDLE.
- (2) Brakes - APPLY as needed.
- (3) Ignition Switch - OFF.
- (4) Master Switch - OFF.

Engine Failure Immediately After Takeoff

Fly the Aircraft!

- (1) Airspeed - Flaps Up 79 MPH (69 kts)
Flaps Down 72 MPH (63 kts)
- (2) Brakes - APPLY As Needed.
- (3) Ignition Switch - OFF.
- (4) Master Switch - OFF.

Engine Failure During Flight

Fly the Aircraft!

- (1) Airspeed – Best Glide 83 MPH (72 kts)
- (2) Select Emergency Landing Area - PROCEED To It.
- (3) Attempt Engine RESTART.
- (4) Ignition - Check ON.
- (5) Choke - Check OFF.
- (6) Throttle Lever - CRACKED (approximately 1/4" forward).
- (7) Turn Switch to START
- (8) If Engine **DOES NOT** Start - Follow Emergency Landing Procedure Without Engine Power.

FORCED LANDINGS

Emergency Landing Without Engine Power

Fly the Aircraft!

- (1) Flaps - As REQUIRED for Landing Site.
Airspeed - Flaps Up 83 MPH (72 kts).
 Flaps Down 78 MPH (68 kts).
- (2) Fuel Selector Valve - OFF.
- (3) All Switches - OFF.
- (4) Open canopy and lock open prior final approach
- (5) Touchdown - MINIMUM FLIGHT SPEED.
- (6) Brakes - APPLY As Needed.

Precautionary Landing With Engine Power

Fly the aircraft!

- (1) Select Field - FLY OVER, noting terrain, obstructions and wind direction.
- (2) Flaps - AS REQUIRED (for landing site).
- (3) Airspeed – Flaps UP 72 MPH (63 kts).
 Flaps FULL DOWN 65 MPH (57 kts) (Use flaps as required for
 landing site).
- (4) Master Switch - OFF.
- (5) Canopy – Locked OPEN.
- (6) Touchdown - MINIMUM FLIGHT SPEED.
- (7) Ignition - OFF.
- (8) Brakes - APPLY As Needed.

Ditching

Fly the aircraft!

- (1) Flaps - FULL.
Airspeed - 65 MPH (57 kts).
- (2) Power - RATE OF DESCENT - 200 ft/min or less (adjust with power).
- (3) Approach - High Winds - INTO THE WIND. Light Winds - PARALLEL TO
SWELLS.
- (4) Tighten seat belts
- (5) Canopy – Locked OPEN.
- (6) Touchdown - LEVEL ATTITUDE AT ESTABLISHED DESCENT RATE.
- (7) Place folded coat or cushion over face at touch down
- (8) Aircraft - Unlatch Seat Belts and EVACUATE through doors.
- (9) Life Raft and Vests - INFLATE (If onboard).

LANDING WITH A DEFECTIVE MAIN WHEEL TIRE

Fly the Aircraft

- (1) Approach - NORMAL
- (2) Flaps – as desired
- (3) Touchdown - GOOD TIRE FIRST. Hold the aircraft off of the defective tire as long as possible with aileron control.
- (4) Canopy – Locked OPEN.

FIRES

During Start On Ground

- (1) Cranking - CONTINUE, to get a start which would suck the flames and accumulated fuel through the carburetor and into the engine.

If Engine Starts:

- (2) Power – 4500 - 5000 RPM for a few minutes.
- (3) Engine - SHUTDOWN and inspect for damage.

If Engine fails to Start:

- (4) Continue cranking with throttle full open while ground attendants obtain fire extinguisher; when ready to extinguish fire -
- (5) Ignition - OFF.
- (6) Master Switch - OFF.
- (7) Fuel Selector Valve - OFF.
- (8) Fire Damage - INSPECT, repair damage or replace damaged components or wiring before conducting another flight.

Engine Fire In Flight

Fly the aircraft!

- (1) Fuel Selector Valve - OFF.
- (2) Ignition switch- OFF.
- (3) Master switch - OFF.
- (4) Cabin heat - OFF.
- (5) Airspeed - 113 MPH (98 kts) (If fire is not extinguished, increase glide speed to find an airspeed which will provide an incombustible mixture
CAUTION: DO NOT EXCEED VNE
- (6) Forced Landing - EXECUTE (as described in Emergency Landing Without Engine Power).

Electrical Fire In Flight

Fly the aircraft!

- (1) Master Switch - OFF.
- (2) All Other Switches (except Ignition switch) OFF.
If fire appears out and electrical power is necessary for continuance of flight:
- (3) Circuit Breakers - CHECK for faulty circuit, do not reset faulty circuit
Master Switch - ON.
- (4) Radio/Electrical Switches - ON one at a time, with delay after each until short circuit is localized.

AMPLIFIED PROCEDURES

ENGINE FAILURE

If an engine failure occurs during the takeoff run, the most important thing to do is to stop the aircraft on the remaining runway. Those extra items on the checklist will provide added safety during a failure of this type.

The first response to an engine failure, after takeoff, is to promptly LOWER the nose and establishes a glide attitude (check and maintain speed). In most cases, the landing should be planned straight ahead with only small heading corrections to avoid obstructions. Of course, the number one priority is to land the aircraft as smoothly and accurately as possible.

IMPORTANT: Altitude and airspeed are seldom sufficient to execute a 180 degree gliding turn back to the runway.

After an engine failure in flight, the best glide speed of 83 mph (72 knots) should be established as quickly as possible. While gliding toward a suitable landing site, an effort should be made to identify the cause of the failure. If time permits, an engine restart should be attempted as shown on the checklist. If the engine cannot be restarted, a forced landing without power must be completed.

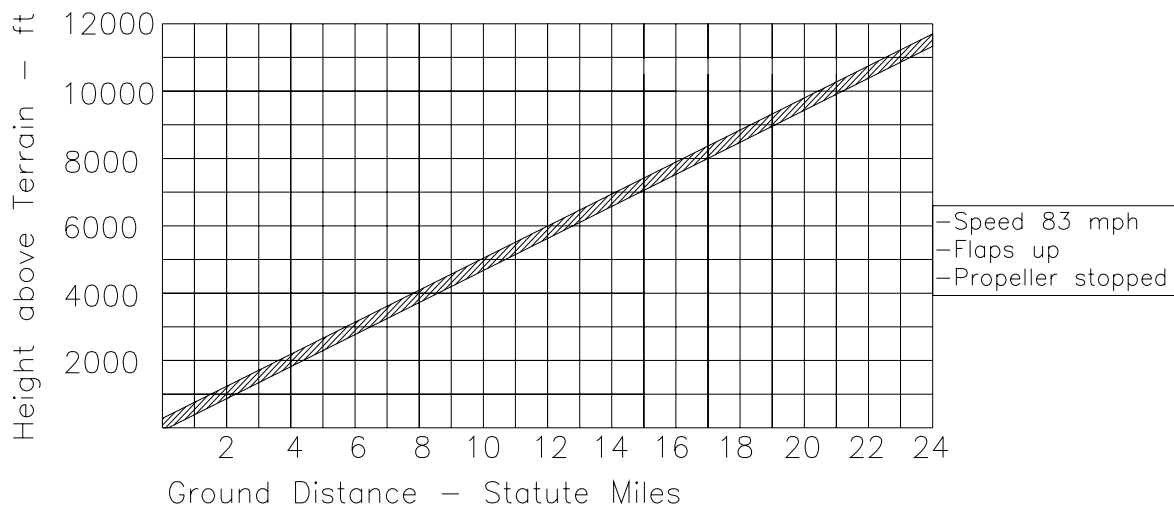

FIGURE 5-1 - MAXIMUM GLIDE

FORCED LANDINGS

Select a suitable landing site and proceed to it. If all attempts to restart the engine fail and a forced landing is imminent, follow the checklist for Emergency Landing Without Power.

Before attempting an off airport landing with engine power available, fly over the landing site at a safe but low altitude to inspect the terrain. Check for obstructions and surface conditions. Plan your approach and touch down.

When preparing to ditch, it is advisable to jettison any heavy objects from around the Pilot, including heavy clothing. Of course, if time permits, ditch as close to land or a water vessel as possible.

Transmit Mayday message on 121.5 MHz giving location and intentions.

RECOVERY FROM A SPIRAL DIVE

If a spiral dive is encountered, proceed as follows:

- (1) Retard Throttle to **IDLE**.
- (2) Stop the turn by using coordinated aileron and rudder in opposite direction of spiral dive.
- (3) Cautiously apply elevator back pressure to slowly reduce the airspeed to below maneuvering speed.

SPINS

Intentional spins in the S-19 aircraft are **PROHIBITED**.

Should an inadvertent spin occur, the following recovery procedure should be used:

- (1) Retard the throttle to **IDLE**.
- (2) Place the ailerons in the **NEUTRAL** position.
- (3) Apply rudder opposite to the direction of rotation.
- (4) Move the control stick (yoke) forward to "break" the stall.
- (5) Hold these control inputs until rotation stops.
- (6) As rotation stops, neutralize rudder and apply back pressure on the control stick to slowly reduce airspeed to normal cruise speed.

ROUGH ENGINE OPERATION

IGNITION MALFUNCTION

A sudden engine roughness or misfiring is usually evidence of ignition problems. Switching from BOTH to either L or R ignition switch position will identify which circuit is malfunctioning. Select different power settings, if continued operations on BOTH circuits is practicable.

If not, switch to the good circuit and proceed to the nearest airport for repairs.

CARBURETOR ICE

A sudden engine roughness or loss of rpm could be Carburetor Ice problems. Actuate Carburetor Heat by pulling on the Carburetor Heat Control Knob.

As soon as the engine roughness or suspected carburetor ice is gone, turn off the Carburetor Heat. Repeat as necessary.

17D - NORMAL PROCEDURES

This section provides checklists and amplified (detailed) procedures for the conduct of normal operations.

AIRSPEEDS FOR NORMAL OPERATION

Following airspeeds are based on operations at a Maximum Gross Weight of 1320 lbs.

NOTE: ALL SPEEDS ARE INDICATED AIRSPEEDS MPH (kts)

Takeoff:

Normal Climb out	75-80 (65-70)
Short Field Takeoff, flaps HALF, speed at 50 ft	70 (61)

Enroute Climb, Flaps UP:

Normal	75-85 (65-74)
Best Rate of Climb, Vy, Sea Level	75 (65)
Best Angle of Climb, Vx Sea Level	70 (61)

Landing Approach:

Normal Approach, Flaps UP	75 (65)
Normal Approach , Flaps FULL	65 (57)
Short Field Approach, Flaps FULL	65 (57)

Balked Landing (Missed Approach):

Maximum Power, Flaps half	70 (61)
---------------------------	---------

Maximum Recommended Rough Air Penetration Speed:

120 (104)

Maximum Demonstrated Crosswind Velocity:

Takeoff	20 kts
Landing	20 kts

OPERATIONAL CHECKLISTS

PREFLIGHT INSPECTION

Visually inspect the aircraft for its general condition during the walk around.

In addition to the items listed on the preflight checklist, look for signs of visible ice if applicable. The presence of ice on the aircraft wings and tail will adversely affect the aircraft's performance. In all cases, remove the ice **BEFORE** beginning any flight operations. Always exercise due care and good judgment. It is also recommended to remove visible moisture (water) from at least wings and tail surfaces because of its negative effects on performance of the aircraft.

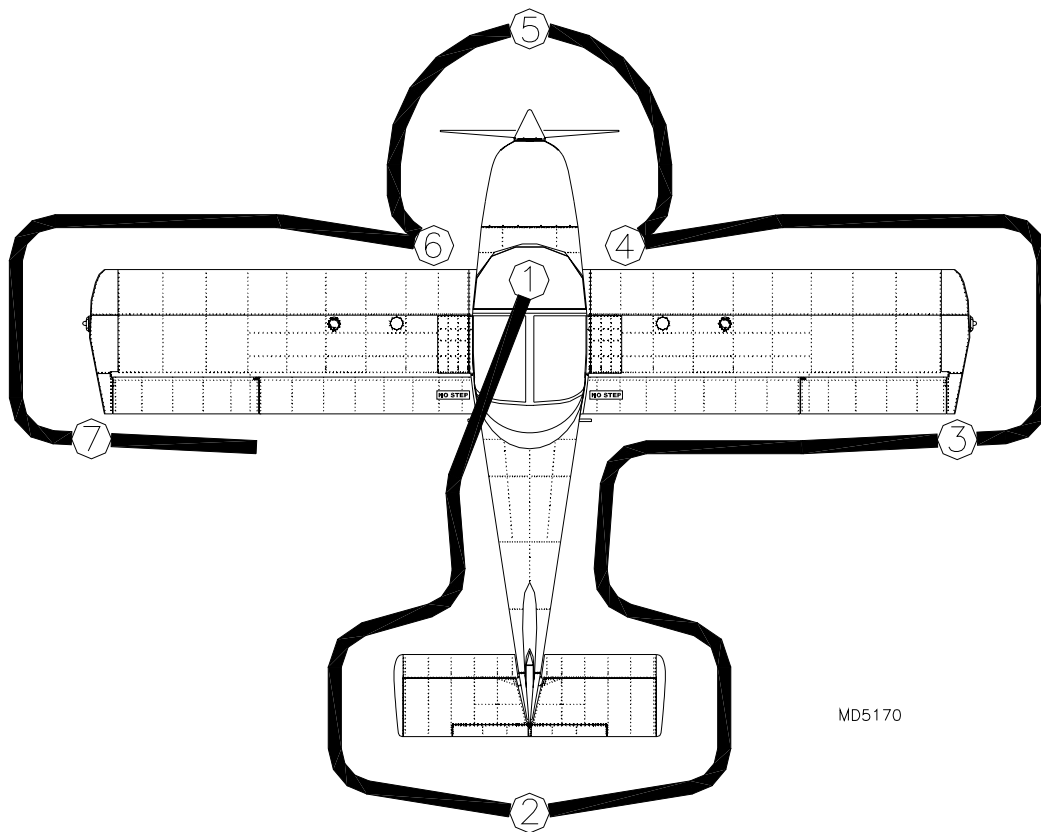

FIGURE 17E-1: PREFLIGHT INSPECTION SEQUENCE

The entire outer surface of the aircraft should be inspected for damage of any kind during the preflight inspection.

1 Cabin

- (1) Aircraft Flight Manual & Required Aircraft Documentation – AVAILABLE IN CABIN
- (2) Parking brake – SET
- (3) Ignition switch - OFF
- (4) Master switch - OFF
- (5) Avionics Master - OFF
- (6) Circuit Breakers - CHECK IN
- (7) Fuel Selector Valve - ON
- (8) Fuel Quantity Indicator – CHECK QUANTITY
- (9) Throttle Lever – MOVEMENT- free
- (10) Seats – ADJUST POSTION – CHECK PINS
- (11) Cabin – CHECK FOR FOREIGN ARTICLES
- (12) Baggage - SECURE
- (13) For Solo flight – SECURE passenger seat belt
- (14) Check fuselage.

2 Empennage

- (1) Vertical fin - CHECK
- (2) Control surfaces – CHECK freedom of movement and security
- (3) Tail Tie Down – DISCONNECT
- (4) Surface – CHECK for damage
- (5) Check fuselage.

3 Right Wing - Trailing Edge

- (1) Fuel quick drain valve on bottom of wing - DRAIN at least a cupful of fuel (using sampler cup) to check for water, sediment and proper fuel grade before first flight of day and after each refueling. If water is observed, take further samples until clear, and then gently rock the wings to move any additional contaminants to the sampling points. Take repeated sampling from all points until no contamination is found
- (2) Flap – CHECK security
- (3) Aileron – CHECK freedom of movement and security
- (4) Surface - CHECK for damage

4 Right Wing

- (1) Wing tip – CHECK security
- (2) Leading edge – CHECK condition, dents, nicks
- (3) Wing Tie Down - DISCONNECT
- (4) Fuel filler cap – CHECK secure
- (5) Main wheel tire – CHECK for proper inflation
- (6) Main Wheel – CHECK security, brake
- (7) Surface - CHECK - damage

5 Nose

WARNING – Do not stand within the arc of the propeller, check ignition off, throttle closed and park brake set before rotating the propeller by hand.

- (1) Fuel quick drain valve on bottom of cowling (left side) - DRAIN at least a cupful of fuel (using sampler cup) to check for water, sediment and proper fuel grade before first flight of day and after each refueling. If water is observed, take further samples until clear, and then gently rock the wings to move any additional contaminants to the sampling points. Take repeated sampling from all points until no contamination is found
- (2) Engine oil dipstick/ filler cap - CHECK oil level, then check filler cap secure. Prior to oil check turn the propeller several times by hand to pump oil from the engine into the oil tank, or let the engine idle for 1 min. This process is finished when air is returning back to the oil tank and can be noticed by a murmur from the open oil tank when the prop is turned by hand.
- (3) Carburetor and air filter – CHECK security
- (4) Radiator fluid over-flow bottle – CHECK fluid level
- (5) Propeller and spinner – CHECK for nicks, dents and security
- (6) Engine cooling air inlets and oil cooler – CHECK of obstructions
- (7) Engine cooling air outlet, radiator – CHECK of obstructions
- (8) Exhaust – CHECK – loose damage
- (9) Nose gear and attach – CHECK freedom of movement

6 Left Wing

- (1) Main wheel tire – CHECK for proper inflation
- (2) Main Wheel – CHECK security, brake
- (3) Fuel filler cap – CHECK secure
- (4) Wing Tie Down – DISCONNECT
- (5) Pitot tube – CHECK security
- (6) Leading edge – CHECK condition, dents, nicks
- (7) Wing tip – CHECK security
- (8) Surface – CHECK - damage

7 Left wing - Trailing Edge

- (1) Aileron – CHECK freedom of movement and security
- (2) Flap – CHECK security
- (3) Fuel quick drain valve on bottom of wing; - DRAIN at least a cupful of fuel (using sampler cup) to check for water, sediment and proper fuel grade before first flight of day and after each refueling. If water is observed, take further samples until clear, and then gently rock the wings to move any additional contaminants to the sampling points. Take repeated sampling from all points until no contamination is found
- (4) Surface – CHECK - damage

BEFORE STARTING THE POWERPLANT

- (1) Preflight Inspection - COMPLETE.
- (2) Passenger Briefing - COMPLETE.
- (3) Seat, seat belts - ADJUST and LOCK.
- (4) Brakes - TEST and SET
- (5) Radio, Electrical Equipment - OFF
- (6) Circuit Breakers - CHECK ON
- (7) Fuel Selector Valve – ON FULLEST TANK.

STARTING THE POWERPLANT**COLD START**

- (1) Throttle - CLOSED.
- (2) Choke - ON.
- (3) Master Switch - ON.
- (4) Propeller Area - CLEAR
- (5) Ignition Switch - START (release when engine starts).
- (6) Throttle adjust – IDLE smooth – up to 2000 RPM
- (7) Oil pressure - CHECK
- (8) Choke – OFF
- (9) Avionics master - ON.

HOT START

- (1) Throttle - CLOSED.
- (2) Choke - OFF.
- (3) Master Switch - ON.
- (4) Propeller Area - CLEAR.
- (5) Ignition Switch - START (release when engine starts)
- (6) Throttle adjust – IDLE smooth – up to 2500 RPM
- (7) Oil pressure - CHECK
- (8) Avionics master - ON.

TAXIING

- (1) Brakes - CHECK.
- (2) Control deflection as required for wind

BEFORE TAKEOFF

- (1) Canopy - CLOSED and SECURED.
- (2) Parking Brake - SET.
- (3) Flight Controls - FREE and Correct.
- (4) Flight Instruments - SET.
- (5) Elevator Trim - SET FOR TAKEOFF (center of indicator)
- (6) Fuel Selector Valve – ON FULLEST TANK – Feel for click of fuel valve to ensure valve is in proper position.
- (7) Fuel Quantity - CHECK
- (8) Throttle – 4000 RPM
 - a. Ignition - CHECK (Ignition drop should not exceed 300 RPM on either Ignition and the differential between Ignitions should not be more than 120 RPM).
 - b. Engine Instruments and Voltmeter- CHECK
 - c. Carburetor heat – CHECK – RPM drop
- (9) Throttle – IDLE – adjust friction lock
- (10) Choke - OFF.
- (11) Radios - SET.
- (12) Fuel pump - ON
- (13) Wing flaps – SET for take off
- (14) Brakes - RELEASE

TAKEOFF**NORMAL TAKEOFF**

- (1) Flaps – UP or 1st Notch.
- (2) Carburetor heat – COLD
- (3) Fuel pump - ON
- (4) Throttle – SLOWLY FULL OPEN.
- (5) Climb Speed – 75-80 MPH (65-70 Kts)

SHORT FIELD TAKEOFF

- (1) Flaps – 1st or 2nd Notch.
- (2) Carburetor heat - COLD
- (3) Fuel pump - ON
- (4) Brake - APPLY.
- (5) Elevator Control- FULL BACK
- (6) Throttle – FULL OPEN.
- (7) Brake - RELEASE.
- (8) Climb Speed - 70 MPH (61 Kts) until all obstacles are cleared.
- (9) Flaps - RETRACT slowly after reaching 86 MPH (75 kts)

ENROUTE CLIMB**NORMAL CLIMB**

- (1) Airspeed – 75-85 MPH (65-70 kts)
- (2) Throttle - 5800 RPM for 5 minutes max., 5500 RPM continuous

CRUISE

- (1) Throttle - 4500 to 5500 RPM (Maximum continuous setting).
- (2) Elevator Trim - adjust.
- (3) Fuel pump – OFF- monitor fuel pressure
- (4) Switch fuel tanks every 30 min or as needed to trim roll. Feel for click of fuel valve to ensure valve is in proper position.

APPROACH

- (1) Throttle - AS DESIRED.
- (2) Engine temperatures – MONITOR
- (3) Carburetor heat – FULL HEAT AS REQUIRED

BEFORE LANDING

- (1) Seat, Belts, Shoulder Harness - ADJUST.
- (2) Fuel pump – ON
- (3) Carburetor heat – FULL HEAT AS REQUIRED

LANDING

NORMAL LANDING

- (1) Airspeed (on approach) – Flaps UP - 75 MPH (65 kts).
- (2) Flaps (on final) - AS REQUIRED (below 86 MPH (75 kts))
- (3) Airspeed (on final) – Full Flaps 65 MPH (57 kts)
- (4) Touchdown - MAIN WHEELS FIRST
- (5) Nosewheel - Gently lower
- (6) Brake - MINIMUM REQUIRED for field length and directional control

SHORT FIELD LANDING

- (1) Airspeed (approach) – FLAPS UP 75 MPH (65 kts)
- (2) Flaps (on final) – FULL (below 86 MPH (75kts))
- (3) Airspeed - MAINTAIN 65 MPH (57 kts)
- (4) Power - REDUCE to idle as obstacle is cleared
- (5) Touchdown - MAIN WHEELS FIRST
- (6) Nosewheel - Gently lower
- (7) Brake - APPLY as required for field length and directional control
- (8) Wing Flaps - RETRACT for maximum brake effectiveness

BALKED LANDING

- (1) Throttle – FULL OPEN
- (2) Carburetor heat – COLD
- (3) Airspeed – 70 MPH (61 kts)
- (4) Establish Climb
- (5) Wing Flaps – Slowly RETRACT TO 2/3
- (6) Airspeed – 75-80 MPH (65-70 kts)
- (7) Wing flaps – Slowly RETRACT

AFTER LANDING

- (1) Wing Flaps – UP
- (2) Taxi – SLOWLY
- (3) Control deflections as required for wind
- (4) Carburetor Heat – OFF
- (5) Fuel pump - OFF

SECURING THE AIRCRAFT

- (1) Parking Brake - SET
- (2) Throttle - IDLE
- (3) Radio and Electrical Equipment - OFF
- (4) Master Switch - OFF
- (5) Ignition - OFF
- (6) Control Stick - SECURED
- (7) Aircraft - SECURELY TIED DOWN

AMPLIFIED PROCEDURES

PRE-FLIGHT INSPECTION

The importance of thorough pre-flight cannot be over-emphasized. Follow the recommended pre-flight procedure and develop a systematic, habitual approach. The use of good, sound, reasonable judgment in tandem with the preflight checklist is essential. Ensure "yourself", all parts, components, and the entire aircraft are in an airworthy condition before attempting flight.

If you have any reservations, **DO NOT FLY! ALWAYS** do your own preflight.

Refer to **FIGURE 17E-1**. Starting at the nose, work around the S-19 in a clockwise manner as illustrated.

NOTE: *This suggested outline for a preflight inspection generally covers the critical areas that **MUST** be checked prior to each flight.* In addition, **EVERY** component should be examined, properly maintained, correctly stored or transported, and inspected before each flight to ensure structural integrity and proper flying characteristics.

BEFORE STARTING THE POWERPLANT

Adjust the pilot's seat to the correct position to ensure the rudder pedals and brakes can be reached and actuated in a comfortable manner.

Adjust the seat belts and shoulder straps to ensure all controls can be operated. Make sure the seat belt buckle is securely closed. Check the fuel selector valve position. **CHECK** to see the avionics switch is OFF and all circuit breakers are set.

NEVER use the brake as a parking brake with the intention of leaving the aircraft unattended. The S-19 is a light aircraft!

STARTING THE ROTAX 912ULS POWERPLANT

The powerplant starting procedure on the S-19 involves only a few simple steps. When followed correctly, the powerplant should start with a few turns of the electric starter. The procedure for starting the powerplant when it is cold differs somewhat from a warm engine start.

Starting the engine when it is COLD is done in the following manner. Ensure that the Ignition Switch is OFF and the propeller area is clear (announce "CLEAR PROP"). Place the throttle lever in the IDLE position and the choke in the "ON" position. This is accomplished by pulling the choke handle (pull and hold)

Turn the Master Switch ON. Turn the ignition switch to "START". After the engine starts, RELEASE the ignition switch (should automatically release to the BOTH position) and advance the throttle slightly. After the engine has run for a short time, "CHOKE OFF".

NOTE: *For more specific information regarding powerplant operation, refer to the Rotax Operator's Manual.* The manual contains **IMPORTANT** safety, maintenance, and operating information.

TAXING (Ground Handling)

The S-19 is equipped with a free-swivel nose wheel and is a brake steer aircraft. Concentrate on taxiing till the moment you've tied the aircraft down.

When taxiing, it is important that speed and use of brakes is held to a minimum and that all controls are utilized to maintain directional control and balance as shown in **FIGURE 17E-2**.

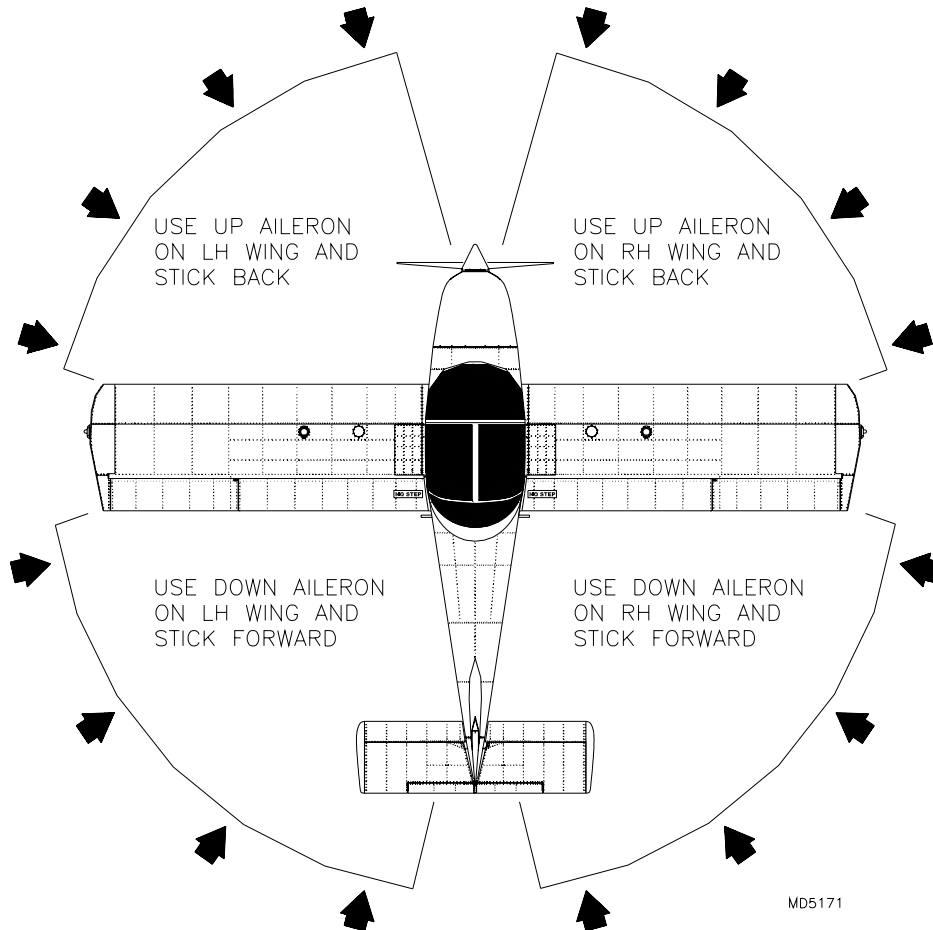

FIGURE 17E-2 - TAXIING DIAGRAM

The arrows identify the wind direction. It is very important to hold the controls as described, even when the aircraft is not moving.

When taxiing in strong crosswinds a little extra throttle will help the aircraft turn due to the increased airflow over the rudder. Caution should be used not to use excessive throttle, sudden throttle movements, or excessive braking.

BEFORE TAKEOFF

Warm the engine up.

Be careful about parking and taxiing with tailwinds as this can reduce the airflow over the radiator causing the engine to overheat.

Select an area that is clear of persons and property that could be adversely affected by the propeller and propeller blast. The area should be free of debris that could damage the propeller. If you are operating around other aircraft, ensure you are clear of runway and taxiway areas.

Move the control stick and rudder pedals to full deflection in all directions. Ensure that they move freely. Inspect all flight control surfaces and ensure that they respond in the correct corresponding directions to the control stick and rudder pedal movements.

The ignition system or "mag" check should be made by running the engine up to 4000 to 4500 RPM as follows. Turn the ignition switch first to the "R" position and note the RPM. Next move the switch back to "BOTH" to clear the other set of plugs. Then move the switch to the "L" position, note the RPM then return the switch to the "BOTH" position. You should observe a slight drop (approximately 100 RPM) in RPM, but NO MORE than 300 RPM for either the "L" or "R" position or a differential of 120 RPM between Ignitions.

The flaps should be moved from FULL UP to FULL DOWN, stopping at each flap setting. Ensure that the flap selector handle seats securely at each setting and visually verify that each flap moves to the correct corresponding position. Set the trim Indicator to middle position.

TAKEOFF

Power Check and Takeoff Roll

Prior to commencing the takeoff roll, align the aircraft in the intended direction of takeoff. When full power is applied, immediately verify that proper takeoff thrust is created. Also feel for any abnormal vibrations and listen for any abnormal noises.

If the takeoff is being made over loose impediments, advance the throttle slowly. This will allow the aircraft to be well into the takeoff roll before high propeller RPM's are reached, and decreases the possibility of propeller damage. The rate the throttle is advanced must be dictated by the available runway and obstructions in the departure path.

Flap Settings

Normal takeoffs are accomplished with flaps up or 1st notch down. Using flaps reduces the ground roll and the total distance to clear an obstacle.

If flaps are used for takeoff, they should be left in that position until all obstacles are cleared and a flap retraction speed of 86 MPH, and minimum altitude of 100 feet AGL, is reached.

The pilot must always be prepared for an engine/power system failure and ensure there is always sufficient altitude, airspeed, and a suitable landing site to perform an "Emergency Landing Without Power".

Short Field Takeoff

Short field takeoffs are performed with 1/3 to 2/3 down flaps. An obstacle clearance speed of 70 MPH (61 Kts) should be used.

Soft Field Takeoff

Short field takeoffs are performed with 2/3 down flaps. An obstacle clearance speed of 70 MPH (61 Kts) should be used. Procedure: Apply brakes; Full power; 2/3 Flaps; Release brakes, Rotate and hold as soon as possible. Let aircraft accelerate and fly. Maintain climb speed 70 MPH (61 Kts).

Crosswind Takeoff

Takeoffs in crosswinds of 5-15 Knots normally are performed with the minimum flap setting necessary for the field length in order to minimize the drift angle immediately after liftoff. The aircraft is accelerated to a speed slightly higher than normal, and then pulled off a bit more abruptly than normal to prevent possible settling back to the runway while drifting. When clear of the ground, neutralize controls as required for coordinated flight and turn the aircraft into the wind to correct for drift. At the beginning of the takeoff roll, it is advisable to apply aileron control into the wind.

ENROUTE CLIMB

A normal enroute climb is performed at 75-85 MPH (65-74 kts) with flaps up. Operation above 5500 RPM is limited to 5 minutes. Monitor engine temperatures and adjust climb speed as required. A higher climb speed will provide better engine cooling.

CRUISE

Normal cruise is performed between 4500 RPM and 5500 RPM. The fuel consumption, speed, and range will vary according to the particular power setting selected. A good number for your cross- country planning is 4 hrs endurance plus 30 min reserve.

In your cross country planning always consider that the weather and wind can change. Plan accordingly and leave yourself room for alternate procedures.

STALLS

The stall characteristics of the S-19 aircraft are conventional. Use slow deceleration. The position and feel of the flight controls can be used as an indication of an impending stall. The control stick will be aft of its normal flight position and the aircraft will feel "mushy". A stall can be terminated by smoothly moving the control stick forward far enough to allow the aircraft to accelerate to normal flight speed.

APPROACH

It is recommended to plan your prolonged descents from high altitudes to allow for small reductions in power every two to five minutes. This will enhance the life of the engine.

Airspeed should be controlled with angle of descent and power. Avoid prolonged descents at low power settings.

LANDING

Normal Landing

Flap position selection for approach and landing should be determined by considering height of obstructions on the approach, wind direction and velocity, and usable runway length. Touchdown on main wheels first. Gently lower nose wheel.

Short Field Landing

Use 65 MPH (57 kts) on short final (with full flaps) and power as required to control the approach angle. Touch down on the main wheels first. Immediately after touchdown gently lower the nose wheel to the ground and apply braking as required. Hold control stick back and retract flaps.

Crosswind Landing

When landing in a crosswind, use a 0 degree flap setting, unless flaps are required for the field length. The wing-low method should be used during approach and touchdown since it will provide the best directional control. This method, when done correctly, will prevent side-loads from being imposed on the landing gear. Continue to hold the ailerons into the wind.

EXAMPLE: *When landing with a crosswind from right, place the control stick to the right as required.*

HOT WEATHER OPERATION

Avoid prolonged engine operation on the ground.

17E - AIRCRAFT GROUND HANDLING AND CARE

GROUND HANDLING

On the ground the aircraft is most easily maneuvered by hand using a tow bar attached to the nose gear. This will help you to maneuver the aircraft in tight spaces.

TIE-DOWN INSTRUCTIONS

If the aircraft must be left unattended outdoors, always secure it with tie-downs. The type of tie-downs used is a matter of personal choice. A good "rule-of-thumb" is to ensure that what you secure the aircraft to (and with) will restrain at least 1320 lbs at each tie-down location. Secure the controls in the cockpit using the seat belts and use the following tie down points:

- Tail
- Left wing
- Right wing

If strong winds or gusts are advised seek shelter for the aircraft.

AIRCRAFT CARE

If your aircraft is to retain that new aircraft performance and dependability, certain inspection and maintenance requirements must be followed. It is recommended to follow a planned schedule of lubrication and preventive maintenance based on the climatic and flying conditions encountered.

WINDSHIELD AND CANOPY

The windshield and canopy are made from Acrylic and the aft canopy is Lexan. **Do not bring Lexan in contact with fuel. Fuel will harm these surfaces almost immediately.** If fuel is spilled accidentally wipe off with lots of water.

Clean the windshield with plenty of water and if you need to, with a mild detergent in low concentration. Rinse thoroughly and dry with a clean soft cloth or towel.

We recommend "Brilliance" for windshield and canopy care.

Brilliance is available from RANS or aircraft supply houses such as Aircraft Spruce.

IMPORTANT: Never use Gasoline, Benzene, Alcohol, Acetone, thinner or glass cleaner on Lexan surfaces (windows).

PAINTED SURFACES

The painted exterior surface of your S-19 aircraft is a durable and long lasting finish.

No polishing or buffing should be required under normal conditions.

It is recommended to keep your aircraft out of the sun as much as possible.

If you keep your aircraft outside it is recommended to wax the exterior surface.

It is also recommended to clean the exterior surface of your aircraft on a regularly base. This can also be accomplished with "Brilliance". It is possible to wash the aircraft with water and a mild soap, followed by a rinse with water and drying with cloths.

INTERIOR CARE

Use a vacuum cleaner to remove dust and loose dirt from the interior and upholstery.

Household spot removers or upholstery cleaner may also be used for the seat upholstery. Always test it on an obscure place on the fabric to be cleaned.

The plastic baggage enclosure can be cleaned with a damp cloth and an automotive plastic interior care product.

The instrument panel, control knobs need only be wiped of with a damp cloth.

17F - REQUIRED PLACARDS AND MARKINGS

AIRSPEED INDICATOR MARKINGS

Airspeed indicator markings and their color code meanings are shown in Table 17G-1.

Marking	IAS Value or Range in MPH (KNOTS)	Meaning
White Arc	45 - 90 (39 -78)	Full Flap Operating Range. Lower limit is maximum weight stalling speed in landing configuration. Upper limit is maximum speed permissible with flaps extended.
Green Arc	51 - 125 (44 - 109)	Normal Operating Range. Lower limit is maximum weight stalling speed at most forward CG with flaps retracted. Upper limit is maximum structural cruising speed.
Yellow Arc	125 - 150 (109 - 130)	Operation must be conducted with caution and in smooth air only.
Red Line	150 (130)	Maximum speed for all operations

Table 17G-1: Airspeed Indicator Markings

PLACARDS

The following labels and placards contain important information needed for proper operation of the S-19 and must be displayed in the location described in this section.

All placards are available through RANS Aircraft Parts Department.

Placards shown below are included on RANS decal sheet KPPL0019.

MASTER FUEL PUMP AVIONICS NAV STROBE PANEL LDG

REG. OUTPUT REG. STARTER TRIM EMS AUX EFIS RADIO XPONDER ICOM GPS

REG. OUTPUT REG. STARTER TRIM ENG INST AUX ATT IND HEADING IND RADIO XPONDER ICOM GPS

TIRE PRESSURE 28-32 PSI

TIRE PRESSURE 28-32 PSI

TIRE PRESSURE 28-32 PSI

HAND HOLD

HAND HOLD

BAGGAGE 70 lbs. MAXIMUM

UP
T.O.
DOWN

THROTTLE PUSH OPEN

AUTO PILOT **POSITIVE CHARGE POST** **ELT ACCESS PANEL**

ALTERNATOR ALERT **EMS ALERT** **ALERT VOLUME**

ELT **MUSIC IN** **EMRG. COM** **SPINS PROHIBITED**

SERVICE ENGINE OIL & COOLANT IN ACCORDANCE WITH ENGINE OPERATION MANUAL. CHECK FLUID LEVEL DURING PREFLIGHT INSPECTION.

FUEL TANK CAPACITY
12.0 GALLONS US EACH WING
TOTAL OF 24 GALLONS
APPROVED FUEL
AUTOMOTIVE GASOLINE TO ASTM 4814
MINIMUM AKI (ANTI KNOCK INDEX (R+M)/2) OF 91
10% ALCOHOL CONTENTS ALLOWED
OR
AVIATION GASOLINE 100LL GRADE
AVIATION FUEL (BLUE)
FOR ADDITIONAL INFORMATION
SEE ENGINE OPERATORS MANUAL
WARNING:
SEE MAINTENANCE MANUAL FOR SPECIFIC
MAINTENANCE INSTRUCTIONS WHEN USING
AVIATION FUEL.

NO STEP

NO STEP

NO STEP

NO STEP

**FUEL CAPACITY 12 GAL. US
MINIMUM AKI
(ANTI KNOCK INDEX (R+M)/2)
OF 91
10% ALCOHOL
CONTENTS ALLOWED**

**FUEL CAPACITY 12 GAL. US
MINIMUM AKI
(ANTI KNOCK INDEX (R+M)/2)
OF 91
10% ALCOHOL
CONTENTS ALLOWED**

THIS AIRCRAFT WAS MANUFACTURED IN ACCORDANCE WITH LIGHT SPORT AIRCRAFT AIRWORTHINESS STANDARDS AND DOES NOT CONFORM TO STANDARD CATEGORY AIRWORTHINESS REQUIREMENTS

PARKING BRAKE PULL SET

CABIN HEAT PULL ON

CARB HEAT PULL ON

CHOKER PULL ON

OFF

FUEL **FUEL**

LEFT ON **RIGHT ON**

MD5172

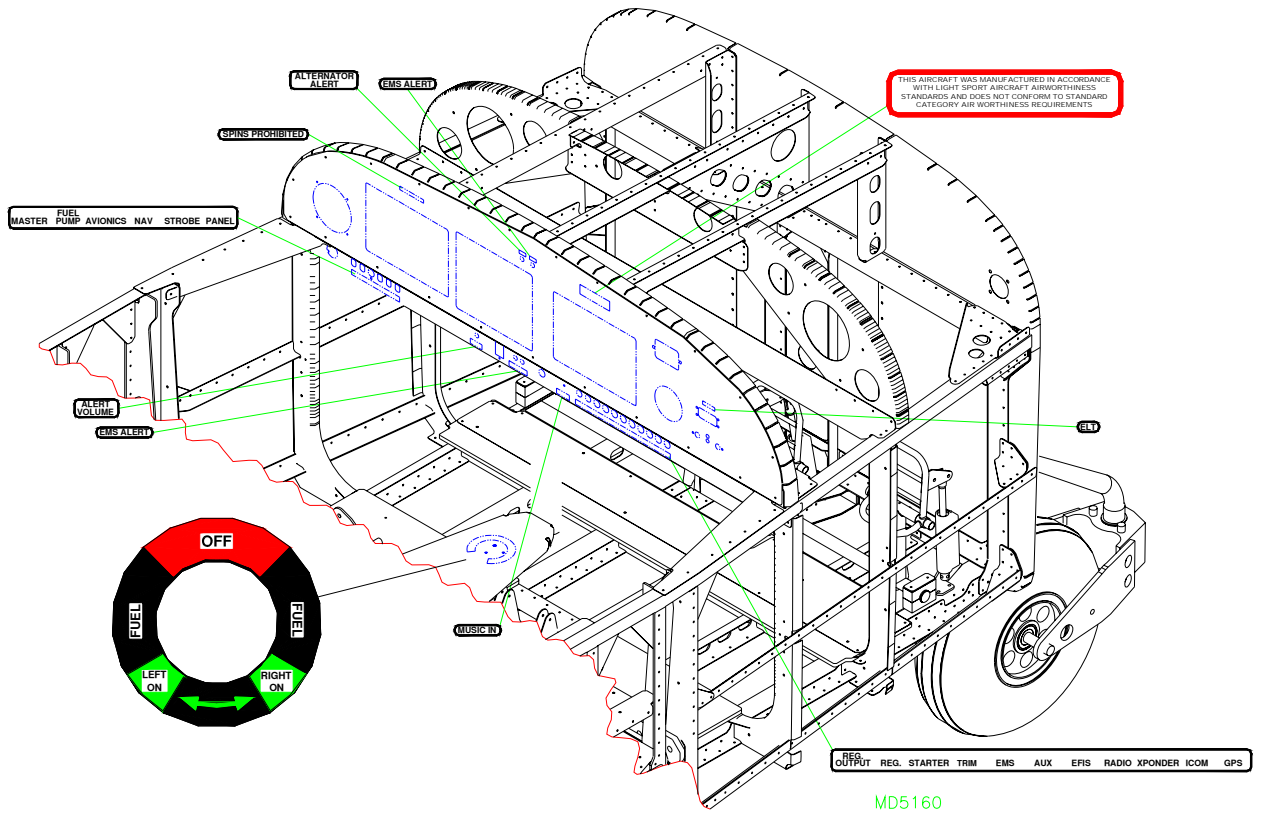

17G - SUPPLEMENTARY INFORMATION

FAMILIARIZATION FLIGHT PROCEDURES

The pilot should familiarize themselves thoroughly with this Manual, ROTAX Engine Operators Manual, applicable Aviation Regulations, and the aircraft itself, before any solo flight is attempted.

Scope and detail of a familiarization flight will depend on level of experience and currency of the pilot.

Any familiarization flight shall include at least all Normal Procedures including a preflight inspection.

It is also recommended, to perform slow flight, power off stalls in clean and flapped configuration.

All emergency procedures including recovery from a spiral dive or spin shall get at least reviewed.

For pilots with little or no experience in light aircraft, additional the special characteristics of such shall be reviewed.

PILOT OPERATING ADVISORIES

The S-19 shall only be operated by pilots with proper training.

The S-19 is a swivel nose wheel aircraft and as such, requires special attention on the ground.

Always deflect the controls as required in windy conditions.

If the equipped with optional dual brakes on the passenger rudder pedals. Always brief the passenger to remove their feet from the pedals, at least for take off and landing.

Additional passenger briefings are recommended as required.

Should the canopy open in flight, **fly the aircraft first**, before you attempt to do anything. The S-19 handles well with the canopy open. Due to aerodynamic pressure the canopy will only open between 1" or 2", and can easily be closed. Bring the aircraft in horizontal level flight and slow it down to about 60 mph, reach for the canopy handle, push the canopy forward, and lock the canopy.

CAUTION: *If canopy opens in flight, continue to fly the aircraft, trim to hands-off level flight if possible, then close canopy.*